

Mathematics

Class IX (2026 – 27)

Introduction:

The Mathematics curriculum for the Secondary stage has been redesigned in alignment with the National Education Policy 2020 and the National Curriculum Framework for School Education (NCF – SE) 2023, prioritizing deep conceptual understanding and logical reasoning. The revised syllabus places strong emphasis on developing core mathematical competencies, including problem-solving, visualisation, mathematical modelling, mathematical communication, computational thinking, and data analytics. The syllabus integrate Indian Knowledge System with contemporary mathematical knowledge, highlighting the rich contributions of Indian mathematicians to foster a sense of pride and historical context. A deliberate shift from rote learning to competency-based education ensures that students build deep conceptual understanding and logical reasoning rather than mere procedural fluency. Greater emphasis has been laid on the integration of real-life applications and experiential learning, encouraging students to connect mathematical concepts with everyday situations and cross-disciplinary contexts. Greater emphasis has been laid on competency based learning outcomes encouraging students to connect mathematical concepts with everyday situations and inter-disciplinary contexts. Continuous and holistic assessment through projects, activities, and investigations forms an integral part of the learning process, moving beyond summative examinations.

At the secondary stage, the curriculum focuses on developing essential global mathematical competencies, including mathematical representation through quantities and relations, mathematical modelling and algorithm building, and effective mathematical communication. The study of the number system, algebra, geometry, mensuration, statistics and probability is designed to build a strong foundation for higher education while enhancing functional life skills. The curriculum thus aims to build rich mathematical learning frameworks not only for higher academic pursuits but also for the practical demands of life in a rapidly changing, data-driven world.

Objectives: The broad objectives of teaching Mathematics at the secondary stage are to help the learners to:

- develop logical thinking, critical reasoning, and a structured approach to problem-solving;
- build the ability to recognise, analyse, and solve diverse problems with confidence and adaptability;
- communicate mathematical ideas effectively using appropriate language, symbols, and representations;
- appreciate the beauty, history, and real-life relevance of Mathematics as a discipline;
- connect mathematical concepts to fields such as Science, Technology, Engineering, and Economics;
- engage in both collaborative and independent mathematical exploration and learning;
- develop habits of precision, accuracy, and logical consistency in mathematical work;
- build confidence to explore, experiment, and grow in mathematical understanding without fear of failure.

Curricular Goals (CGs) and Competencies (Cs) from the NCF-SE 2023

CG-1: Understands numbers (natural, whole, integer, rational, irrational, and real), ways of representing numbers, relationships amongst numbers, and number sets.

C-1.1 Develops understanding of numbers, including the set of real numbers and its properties.

CG-2: Builds deductive and inductive logic to prove theorems related to numbers and their relationships (such as '2 is an irrational number', a recursion relation for *Virahanka* numbers, a formula for the sum of the first n square numbers).

C-2.1 Understanding of powers (radical powers) and exponents.

CG-3: Discovers and proves algebraic identities and models real-life situations in the form of equations to solve them.

C-3.1 States and proves remainder theorem, factor theorem, and division algorithm.

C-3.2 Models and solves contextualised problems using equations (for example, simultaneous linear equations in two variables or single polynomial equations), and draws conclusions about a situation being modelled.

C-3.3 Learns Brahmagupta's quadratic formula (in both symbolic and poetic form) and its derivation, and uses it to solve some of the poetic puzzles of Bhaskara as well as modern-day problems.

CG-4: Analyses characteristics and properties of two-dimensional geometric shapes, and develops mathematical arguments to explain geometric relationships.

C-4.1 Describes relationships including congruence of two-dimensional geometric shapes (such as lines, angles, triangles) to make and test conjectures and solve problems.

C-4.2 Proves theorems using Euclid's axioms and postulates for triangles and quadrilaterals, and applies them to solve geometric problems.

C-4.3 Proves theorems about the geometry of a circle, including its chords, subtended angles, inscribed polygons, and area in terms of pi.

C-4.4 Understands the irrationality of pi, the best approximations to be discovered over human history, and the first exact formula (infinite series) for pi given by Madhava.

C-4.5 Specifies locations and describes spatial relationships using coordinate geometry, for example, plotting a pair of linear equations and graphically finding the solution, or finding the area of triangle with given coordinates as vertices.

C-4.6 Understands the definitions of the basic trigonometric functions, their history and motivation (including the introduction of the sin and cos functions by Aryabhata using chords), and their utility across the sciences.

CG-5: Derives and uses formulae to calculate areas of plane figures, surface area, and volumes of solid objects.

C-5.1 Visualises, represents, and calculates the area of a triangle using Heron's formula and its generalisation to cyclic quadrilaterals given by Brahmagupta's formula.

C-5.2 Visualises and uses mathematical thinking to discover formulae to calculate surface areas and volumes of solid objects (cubes, cuboids, spheres, hemispheres, right circular cylinders or cones, and their combinations).

CG-6: Analyses and interprets data using statistical concepts (such as measures of central tendency, standard deviations) and probability.

C-6.1 Applies measures of central tendencies, such as mean, median, and mode.

C-6.2 Applies concepts from probability to solve problems on the likelihood of everyday events.

CG-7: Begins to perceive and appreciate the axiomatic and deductive structure of Mathematics.

C-7.1 Proves mathematical statements and carries out geometric constructions using stated assumptions, axioms, postulates, definitions, and mathematics vocabulary.

C-7.2 Visualises and appreciates geometric proofs for algebraic identities and other 'proofs without words'.

C-7.3 Proves theorems using Euclid's axioms and postulates for angles, triangles, quadrilaterals, circles, area-related theorems for triangles, and parallelograms.

C-7.4 Constructs different geometrical shapes like bisectors of line segments, angles and their bisectors, triangles, and other polygons, satisfying given constraints.

CG-8: Builds skills, such as visualisation, optimisation, representation, and mathematical modelling along with their application in daily life.

C-8.1 Models daily-life phenomena and uses representations, such as graphs, tables, and equations to draw conclusions.

C-8.2 Uses two-dimensional representations of three-dimensional objects to visualise and solve problems, such as those involving surface area and volume.

C-8.3 Employs optimisation strategies to maximise desired quantities (such as area, volume, or other output) under given constraints.

CG-9: Develops computational thinking, i.e., deals with complex problems and is able to break them down into a series of simple problems that can then be solved by suitable procedures/algorithms.

C-9.1 Decomposes a problem into sub-problems.

C-9.2 Describes and analyses a sequence of instructions being followed.

C-9.3 Analyses similarities and differences among problems to make one solution or procedure work for multiple problems.

C-9.4 Engages in algorithmic problem-solving to design such solutions.

CG-10: Knows and appreciates important contributions of mathematicians from India and around the world.

C-10.1 Recognises the important contributions made by mathematicians (Indian and others) in the field of Mathematics (such as the evolution of numbers, geometry, and algebra).

C-10.2 Recognises modern contributions to Mathematics made in both India and abroad, and understands the next frontiers and next major open questions in the field of Mathematics.

CG-11: Explores connections of Mathematics with other subjects.

C-11.1 Applies mathematical knowledge and tools to analyse problems or situations in multiple subjects across Science, Social Science, Visual Arts, Music, Vocational Education, and Sports.

COURSE STRUCTURE CLASS – IX

| Units | Unit Name | Chapter Name | Marks |
|-------|----------------------------|---|-----------|
| I | Number System | <ul style="list-style-type: none"> Number System | 07 |
| II | Algebra | <ul style="list-style-type: none"> Introduction to Polynomials Sequences and Progressions Exploring Algebraic Identities Linear Equations in Two Variables | 20 |
| III | Coordinate Geometry | <ul style="list-style-type: none"> Coordinate Geometry | 04 |
| IV | Geometry | <ul style="list-style-type: none"> Introduction to Euclid's Geometry: Axioms and Postulates Lines and Angles Triangles – Congruence Theorems 4-gons (Quadrilaterals) Circles | 25 |
| V | Mensuration | <ul style="list-style-type: none"> Area and Perimeter Surface Area and Volume | 14 |
| VI | Statistics and Probability | <ul style="list-style-type: none"> Statistics Introduction to Probability | 10 |
| | Total | | 80 |

| Chapter Name | Key Concepts | Relevant CGs | Competencies |
|---------------|--|-------------------|--|
| | Unit 1: Number System | | No. of periods : 12 |
| Number System | <ul style="list-style-type: none"> Introduction to rational numbers Representation of rational numbers on the number line Density of rational numbers and its proof Finding rational numbers between any two rational numbers Decimal representation of rational numbers Introduction to irrational numbers Proof of irrationality of $\sqrt{2}$ and $\sqrt{3}$ The square root spiral | CG-1, C-1.1, CG-9 | The student will be able to: <ul style="list-style-type: none"> Understand the concept of a rational number. Represent rational numbers on the number line. Understand the properties of rational numbers. Explain the concept of density of rational numbers. Compute decimal representation of rational numbers. Understand the concept of irrational numbers. Prove the irrationality. Construct the square root spiral. Apply computational thinking to represent rational and irrational |

| | | | |
|-----------------------------|--|--------------------|---|
| | | | numbers through algorithms and visual models, generate decimal expansions systematically, and reason about numbers using step-by-step logical procedures. |
| | UNIT II: ALGEBRA | | No. of periods : 66 |
| Introduction to Polynomials | <ul style="list-style-type: none"> Algebraic expressions Definition of a polynomial. Degree of a polynomial Introduction to linear polynomials and applications Exploring linear patterns Modelling linear growth and linear decay Linear relationships Visualising linear relationships Slope and y-intercept of a line $y = ax + b$ | CG-3, C-3.2, CG-9 | <p>The student will be able to:</p> <ul style="list-style-type: none"> Understand the meaning of an algebraic expression. Define a polynomial. Identify the degree, terms and coefficients of terms in a polynomial. Model linear growth and decay using linear polynomials. Explain and identify patterns in linear relationships. Identify the slope and y-intercept of a linear equation in two variables. Graph a linear equation in two variables. Use computational thinking to identify patterns, construct linear expressions, and systematically represent and analyse linear relationships using equations and graphs. |
| Sequences and Progressions | <ul style="list-style-type: none"> Introduction to sequences Explicit or general rule of a sequence Recursive rule of a sequence Arithmetic Progressions (AP): nth term, visualising an AP, and practical contexts leading to Aps Sum of the first n natural numbers Geometric Progressions (GP): nth term, visualising a GP, and practical contexts leading to GPs Applications of GP in fractals Tower of Hanoi puzzle | CG-11, C-8.1, CG-9 | <p>The student will be able to:</p> <ul style="list-style-type: none"> Understand the concept of a sequence of numbers. Identify the pattern in a sequence and predict the next few terms. Determine the recursive and explicit rules for different sequences. Obtain the terms of sequence given its recursive and explicit rule. Identify Arithmetic Progressions (AP). Determine the nth term of an AP. Visualise an AP graphically. Identify Geometric Progressions (GP). Determine the nth term of a GP. Visualise a GP graphically. Analyse attributes of fractals using GP. Solve the Tower of Hanoi puzzle. Use computational thinking to identify patterns, write step-by-step rules, and model patterns in sequences and progressions. |

| | | | |
|--|---|---|---|
| <p>Exploring Algebraic Identities</p> | <ul style="list-style-type: none"> • Revisiting algebraic identities • Visualising identities using geometrical models • Factorisation of algebraic expressions using identities • More identities and their applications • Visualising factorisation of quadratic expressions through algebra tiles and without using algebra tiles • Finding new identities • Simplifying rational expressions | <p>CG-7, C-7.2, CG-9</p> | <p>The student will be able to:</p> <ul style="list-style-type: none"> • Visualise algebraic identities using geometric models. • Determine the factors of algebraic expressions using identities. • Interpret factors of quadratic expressions through geometric models. • Find simplified versions of rational expressions. • Use computational thinking strategies, such as decomposition and step-by-step procedures to visualise algebraic identities, factor expressions, and simplify rational expressions. |
| <p>Linear Equations in Two Variables</p> | <ul style="list-style-type: none"> • Introduction to linear equations in two variables through practical examples • Solution of linear equation in two variables: graphical representation • Slope-intercept form of linear equation in two variables • Drawing graphs of linear equations when x and y assume only certain values • Pair of linear equations in two variables • Graphical method for solving a pair of linear equations in two variables • Nature of solutions: consistency and inconsistency • Algebraic methods of solving a pair of linear equations: substitution and elimination method | <p>CG-3, C-3.2, C-8.1, CG-9</p> | <p>The student will be able to:</p> <ul style="list-style-type: none"> • Understand the concept of a linear equation in two variables. • Graph a pair of linear equations. • Solve a pair of linear equations graphically. • Solve a pair of linear equations through the methods of substitution and elimination. • Determine the nature of solutions of a pair of linear equations. • Model and solve contextualised problems using a pair of linear equations and draw conclusions. • Model daily-life phenomena using representations, such as graphs, tables, and equations. • Use computational thinking to systematically represent, solve, and interpret pairs of linear equations through graphs, tables, and step-by-step procedures. |

| | | UNIT III: COORDINATE GEOMETRY | No. of periods : 6 |
|--|--|--------------------------------------|---|
| Coordinate Geometry | <ul style="list-style-type: none"> • Brief history of coordinate geometry • The 2-D Cartesian coordinate system • Distance between two points in the 2-D plane • Midpoint of the line-segment between two points in the 2-D plane | CG-4, C-4.5, CG-9 | <p>The student will be able to:</p> <ul style="list-style-type: none"> • Specify locations and the position of one point relative to another point using coordinates. • Represent a floor plan on a grid using coordinates. • Compute the distance between two points using coordinates. • Determine whether three points lie in a straight line using coordinates. • Compute the position of the midpoint of a line segment using coordinates. • Check whether a triangle is right-angled using coordinates. • Apply computational thinking to model situations on the coordinate plane and verify geometric properties through systematic reasoning. |
| | | UNIT IV: GEOMETRY | No. of periods : 69 |
| Introduction to Euclid's Geometry: Axioms and Postulates | <ul style="list-style-type: none"> • History of geometry • Constructing a square with a given side as described in the Baudhayana's Sulbasutras • Discovering Euclid's definitions • Axioms: Axioms of measurement and rules for geometric objects | CG-7, C-7.1, C-7.3 | <p>The student will be able to:</p> <ul style="list-style-type: none"> • Describe how geometry grew from the practical needs ancient civilisations. • Describe contributions of India, Egypt and Greece to the development of geometric ideas. • Understand the role of definitions, axioms, and postulates. • Explain that there are elements of plane geometry (point, line, surface) for which we have an intuitive sense. • State the 5 postulates of Euclidean geometry. • Define parallelism of straight lines. • Explain the construction of a square as given in the Sulbasutras. • Justify simple constructions using the axioms. |
| Lines and Angles | <ul style="list-style-type: none"> • Rays and angles • Measures of angles • Intersecting lines and angles • Pairs of angles • Theorems and examples on intersecting lines • Theorems and examples on parallel lines | CG-7, C-7.1, C-7.3, CG-9 | <p>The student will be able to:</p> <ul style="list-style-type: none"> • Explain the notion of an angle. • Explain the notion of a ray. • Explain that angles are formed between two rays with a common starting point. • State that a straight angle equals two right angles and measures 180° while a right angle measures 90°. |

| | | | |
|---------------------------------------|---|---------------------------|---|
| | | | <ul style="list-style-type: none"> • Classify angles as acute, right, obtuse, or reflex. • Define parallelism. • State and apply the linear pair theorem and its converse. • Follow proof by contradiction in geometry. • Prove that vertically opposite angles are equal. • Identify corresponding, alternate, and interior angles. • Explain transitivity of parallelism. • Explain why a triangle must have at least two acute angles; why it cannot have two obtuse angles, or all three angles less than 60° • Apply computational thinking to analyse geometric ideas by breaking constructions into ordered steps, using axioms and postulates as rules, and justifying geometric results through logical step-by-step reasoning. |
| <p>Triangles: Congruence Theorems</p> | <ul style="list-style-type: none"> • Practical applications of triangles • Proofs of conditions of congruence of triangles • Theorems on triangles • Propositions and their converse • Problems based on applications of theorems on triangles | <p>CG-4, C 4.1, C-7.3</p> | <p>The student will be able to:</p> <ul style="list-style-type: none"> • Explain that a triangle is rigid, unlike a quadrilateral. • Identify uses of triangle rigidity. • Explain why triangles give strength and stability to structures. • Describe what it means for two triangles to be congruent. • Identify correspondence between the vertices, sides, and angles of two congruent triangles. • Use the SAS congruence axiom. • Use the SSS congruence condition. • Use the ASA congruence condition. • Use the RHS congruence condition. • Use the AAS congruence condition. • Prove the basic properties of isosceles triangles. • Explain the notion of a proposition. • Explain the notion of converse of a proposition. • Identify the converse of a given proposition. • Explain that not all converses are true; use counter examples to show that some converses are false. • Explain why SSA is not, in general, a valid congruence condition. |

| | | | |
|-------------------------|--|--------------------|--|
| | | | <ul style="list-style-type: none"> Identify the situations where SSA is a valid congruence condition. Justify the role of diagram accuracy. |
| 4-gons (Quadrilaterals) | <ul style="list-style-type: none"> Properties of parallelograms Important theorems related to parallelograms and their proof Midpoint theorem and its applications Understanding the notion of central symmetry in the context of parallelograms | CG-4, C-4.2, C-7.3 | <p>The student will be able to:</p> <ul style="list-style-type: none"> Frame a precise definition of a 4-gon. Prove various characterisations of a parallelogram. Prove the midpoint theorem. Prove a converse of the midpoint theorem. Prove that the medians of a triangle are concurrent and each median is divided in the ratio 2:1 at the point of concurrence. Prove that the 4-gon formed by joining the midpoints of a given 4-gon is a parallelogram. Find the coordinates of the midpoint of a line segment given its end points and find the coordinates of the fourth vertex of a parallelogram given the other three. Understand reflection and rotation symmetries of 4-gons. Understand how any 4-gon can tile a plane. Practice forming logical converses of statements and asking questions guided by converses of theorems. Engage in drawing, measurement and paper manipulation activities to discover geometric patterns involving triangles and 4-gons. |
| Circles | <ul style="list-style-type: none"> Practical applications and uses of circles Definitions related to a circle — centre, diameter, and radius Chords and the angles they subtend Midpoints and perpendicular bisectors of chords Distance of chords from the centre Subtended angles by an arc Cyclicity of points | CG-4, C-7.3, CG-9 | <p>The student will be able to:</p> <ul style="list-style-type: none"> State the definition of a circle. Explain the meanings of the terms 'chord', 'diameter', 'radius', 'arc', 'segment', and 'sector'. Explain why there exists a unique circle through three non-collinear points. Construct the circumcircle and circumcentre of a triangle. Describe the location of the circumcentre for acute, obtuse, and right-angled triangles. Explain what 'angle subtended by an arc at the centre' means. Explain why 'equal chords subtend equal angles at the centre'. |

| | | | |
|----------------------------------|--|-------------------|--|
| | | | <ul style="list-style-type: none"> • Explain why ‘chords that subtend equal angles at the centre are equal’. • Explain why ‘the line from the centre of a circle to the midpoint of a chord is perpendicular to the chord’. • Explain why ‘a perpendicular from the centre to a chord bisects the chord’. • State the relationship between length of a chord and its distance from the centre of the circle. • Explain why ‘equal chords are equidistant from the centre (and conversely)’. • Explain why ‘among unequal chords, the longer chord is closer to the centre’. • Explain why ‘the diameter is the longest chord’. • Explain why ‘the angle subtended by an arc at the centre is double the angle subtended by the arc at any point on the remaining part of the circle’. • Explain why ‘angles in the same segment of a circle are equal’. • Explain why ‘the angle in a semicircle is a right angle’. • Determine when four given points are concyclic. • Explain why ‘a quadrilateral with supplementary opposite angles is cyclic, and conversely’. • Explain how circular wheels have influenced transport, farming, building, and technology. • Identify cultural motifs involving circles, for example, the Dharmachakra, Ashoka Chakra, Sudarshan Chakra. • Use computational thinking to break down circle-related problems, apply geometric rules step-by-step, and verify properties of figures, such as chords, angles, and cyclic quadrilaterals through systematic reasoning. |
| | UNIT V: MENSURATION | | No. of periods : 27 |
| Mensuration : Area and Perimeter | <ul style="list-style-type: none"> • Perimeter of shapes • Perimeter of a circle: Introduction to Pi and its irrationality • Length of an arc | CG-5, C-5.1, CG-9 | <p>The student will be able to:</p> <ul style="list-style-type: none"> • Define perimeter as the length around the boundary of any shape. • Explain that the circumference-to-diameter ratio is constant for all circles. |

| | | | |
|---------------------------------------|---|-------------------|---|
| | <ul style="list-style-type: none"> • Area of shapes: rectangles, parallelograms, and triangles • Heron's formula • Squaring a rectangle: Proof from Baudhayana's Sulbasutras • Area of a circle: derivation • Area of the sector of a circle • Brahmagupta's formula for area of a cyclic 4-gon • Heron's formula as a special case of Brahmagupta's formula | | <ul style="list-style-type: none"> • List historical approximations to π (from Archimedes, Aryabhata, and Zu Chongzhi). • Compute the circumference of a circle and the length of an arc. • Apply ideas of circle perimeter and arc-length to real-world contexts. • Explain why a median of a triangle divides it into two triangles of equal area. • Use Heron's formula to compute the area of a triangle from its sides. • Explain the classical problem of 'squaring' a given shape. • Explain how ancient civilisations approximated the area of a circle. • Compute the area of a circle using the formula. • Explain and use the formula for area of a sector of a circle. • Solve problems on areas of sectors and segments of circles. • State Brahmagupta's formula for the area of a cyclic quadrilateral in terms of its sides. • Explain why Heron's formula is a 'special case' of Brahmagupta's formula. • Explain the notion of 'special case' and 'generalisation' in mathematics. • Use computational thinking to break down shapes, apply step-by-step methods to calculate perimeter and area, recognise patterns across formulae, and understand generalisation and special cases in geometry. |
| Mensuration : Surface Area and Volume | <ul style="list-style-type: none"> • Surface areas and volumes of spheres (including hemispheres) and right circular cones | CG-5, C-5.1, CG-9 | The student will be able to: <ul style="list-style-type: none"> • Recognise cuboids and cubes in real-life situations. • Compute the surface area and volume of a cuboid. • Explain how a cube is a 'special case' of a cuboid. • Describe a right circular cylinder using its radius and height. • Compute the surface area and volume of a cylinder. • Recognise cones in daily life, and describe them using radius and height. |

| | | | |
|-----------------------------|---|-------------------|--|
| | | | <ul style="list-style-type: none"> • Compute the surface area and volume of a cone. • Recognise a pyramid, and identify its base and apex. • Compute the surface area and volume of a pyramid. • Recognise spheres in real-life situations. • Compute the surface area and volume of a sphere. • Use computational thinking to systematically calculate, and compare surface areas and volumes of 3-D shapes by varying dimensions and analysing patterns. |
| | UNIT VI: STATISTICS AND PROBABILITY | | No. of periods : 24 |
| Statistics | <ul style="list-style-type: none"> • Graphical representation of data • Measures of central tendency | CG-6, C-6.1, CG-9 | <p>The student will be able to:</p> <ul style="list-style-type: none"> • Collect, organise, visualise and interpret data to answer a statistical investigative question. • Compute and apply weighted average in different settings. • Read and interpret stacked bar graphs and 100% stacked bar graphs. • Apply computational thinking strategies to analyse real-life data, create appropriate graphical representations, and interpret mean, median and mode for decision-making. |
| Introduction to Probability | <ul style="list-style-type: none"> • Concept of probability and randomness • The probability scale • Empirical probability: analysing statistical data and performing experiments • Theoretical probability: sample space and events • Representing probability through tree diagrams and tables | CG-6, C-6.2, CG-9 | <p>The student will be able to:</p> <ul style="list-style-type: none"> • Understand the concept of randomness. • Describe the likelihood of an event using the probability scale. • Estimate the empirical probability of the occurrence of an event by analysing statistical data. • Define theoretical probability of an event. • Apply the definition of theoretical probability to compute the probability of an event. • Compute probability of events with the help of tree diagrams and tables. • Use computational thinking strategies, such as pattern recognition and simulation, to model random experiments and estimate probabilities. |

MATHEMATICS QUESTION PAPER DESIGN
CLASS – IX (2026-27)

Time: 3 Hrs.

Max. Marks: 80

| S. No. | Typology of Questions | Total Marks | % Weightage (approx.) |
|--------|---|-------------|-----------------------|
| 1 | <p>Remembering: Exhibit memory of previously learned material by recalling facts, terms, basic concepts, and answers.</p> <p>Understanding: Demonstrate understanding of facts and ideas by organizing, comparing, translating, interpreting, giving descriptions, and stating main ideas</p> | 43 | 54 |
| 2 | <p>Applying: Solve problems to new situations by applying acquired knowledge, facts, techniques and rules in a different way.</p> | 19 | 24 |
| 3 | <p>Analysing: Examine and break information into parts by identifying motives or causes. Make inferences and find evidence to support generalizations</p> <p>Evaluating: Present and defend opinions by making judgments about information, validity of ideas, or quality of work based on a set of criteria.</p> <p>Creating: Compile information together in a different way by combining elements in a new pattern or proposing alternative solutions</p> | 18 | 22 |
| | Total | 80 | 100 |

| INTERNAL ASSESSMENT | 20 MARKS |
|---|-----------------|
| Pen Paper Test and Multiple Assessment (5+5) | 10 Marks |
| Portfolio | 05 Marks |
| Lab Practical (Lab activities to be done from the prescribed books) | 05 Marks |

Prescribed Books:

1. Mathematics - Textbook for class IX - NCERT Publication
2. Guidelines for Mathematics Laboratory in Schools, class IX - CBSE Publication
3. Laboratory Manual - Mathematics, secondary stage - NCERT Publication
4. Mathematics exemplar problems for class IX, NCERT publication

MATHEMATICS AT ADVANCED LEVEL (OPTIONAL)

GRADE 9



2026-27

**Academic Unit,
Central Board of Secondary Education**

Integrated Office Complex
Sector-23, Phase - I, Dwarka, New Delhi - 110077

INDEX

| S. No. | Chapters | Pages |
|--------|------------|-------|
| 1. | Sets | 3-23 |
| 2. | Logarithms | 24-39 |

Note: Remaining four (04) chapters will be uploaded shortly.

1.1 Introduction

Let's begin by taking some examples where we use the word "set" without having formally studied it. You must have heard about different blood types. The primary system used for blood typing is the ABO system. The four major blood types under this system are:

- A
- B
- AB
- O

Blood types have very important applications. If a person of blood type 'A' needs blood transfusion, then which **set of people** can donate blood?

OR

A teacher recommends a **set of books** in algebra to the student.

1.2 Set

So, we may talk about a set of people or a set of books in a casual manner. Since set is often used in mathematics, we define this term first.

Definition of a Set

A set is a well-defined collection of objects. The objects in a set are the elements or members of the set.

Three best students of your class is not a set, as best may vary for different individuals.

Some examples of set are:

- (i) A set of students participating in a quiz contest.
- (ii) A set of girls participating in Kho-Kho match.

On the other hand, collection of 3 most interesting books is not a set as different books may interest different students.

1.3 Representation of a Set

- **Roster Form:** One method of writing a set is to list all the elements of the set within braces separated by commas. For example, the set of vowels in English alphabet is written as $V = \{a, e, i, o, u\}$.

Sets are denoted by capital letters.

This method is also known as tabular form.

The fact that “ e is an element of the set V ” is written as $e \in V$ where the symbol ‘ \in ’ means “belongs to”.

Similarly, we use the symbol $c \notin V$ to denote c is not an element of the set V .

Example 1: Write the following sets in Roster form

- (i) Set of whole numbers less than or equal to 5.
- (ii) Set of first 4 terms of the A.P., whose first term is -3 and common difference is 4.

Solution: (i) $A = \{0, 1, 2, 3, 4, 5\}$ (ii) $B = \{-3, 1, 5, 9\}$

Can all sets be written in roster form? Think about it!

- **Set Builder Form**

Another method of writing a set is set builder form. In this method we specify the elements of the given set by its description. All the elements of the set possess a single common property which no element outside the set possess.

For example, the set $V = \{a, e, i, o, u\}$ can be written using this notation as

$$\{x \mid x \text{ is a vowel in English alphabet}\}$$

which is read as, “the set of all elements x such that x is a vowel of the English alphabet.

Example 2: Write the following sets in the set-builder form:

- (i) $\{1, -1\}$
- (ii) $\left\{\frac{2}{3}\right\}$
- (iii) $\left\{\frac{1}{2}, \frac{1}{4}, 1, 2\right\}$

Solution: (i) $\{x \mid x \text{ is an integer and } x^2 = 1\}$

(ii) $\{x \mid x \text{ is fraction equivalent to } 0.\bar{6}\}$

(iii) $\left\{\frac{a}{b} \mid a = 1 \text{ or } 4 \text{ and } b = 2 \text{ or } 4\right\}$

The theory of sets was developed by German mathematician Georg Cantor (1845-1918). He is considered the founder of set theory.

Cantor developed interest in mathematics in his teens. He began his university studies in Zurich but shifted to Berlin the very next year in 1863, where he studied under the eminent mathematician Karl Weierstrass, Ernst Kummer and Leopold Kronecker. He received his doctorate degree in 1867 in Number theory.

Cantor was also interested in philosophy and wrote papers relating his theory of sets to metaphysics. Cantor’s contribution includes the discovery that the set of real numbers is uncountable. He is also noted for his contributions in analysis.

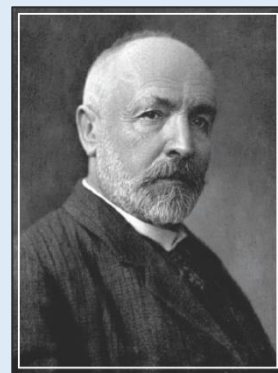

Georg Cantor
(1845-1918)

1.4 Finite and Infinite Sets

Can you make a list of students studying in your class? Of course it can be done easily, as the number of students are finite. Even the school's strength though, a large number, is finite. What about the set of natural numbers or set of real numbers between 2 and 3. Are they finite?

No these constitute infinite sets.

Some infinite sets are given below:

$$A = \{x \mid x \text{ is a multiple of } 5 \text{ and greater than } 20\}$$

$$B = \{x \mid x \text{ is a prime number}\}$$

Example 3: State which of the following sets are finite or infinite:

- (i) $\{x : x \text{ is an integer lying between } 5 \text{ and } 91\}$
- (ii) Set of coordinates of the points lying on a unit circle.
- (iii) $\{x : x \in \mathbb{N} \text{ and } (x, y) \text{ satisfies the equation } 2x + y = 8\}$
- (iv) $\{x : x \text{ is the number of animals on earth}\}$
- (v) $\{x : x \text{ is a digit in the decimal expansion of } \sqrt{2}\}$

Solution:

- (i) Since the set is $\{6, 7, 8, \dots, 90\}$ so it is a finite set.
- (ii) There are infinite points lying on a circle so its an infinite set.
- (iii) Infinite points (x, y) where $x \in \mathbb{N}$ lies on the line $2x + y = 8$. So set of values of abscissa forms an infinite set.
- (iv) Set of animals on the earth is finite.
- (v) $\sqrt{2}$ is an irrational number, so its decimal expansion is non-terminating, but the digits occurring in decimal expansion of $\sqrt{2}$ is finite.

Example 4: Write the following sets in roster form:

- (i) $\{x \mid x \text{ is an odd natural number between } 3 \text{ (excluding) and } 11 \text{ (including)}\}$
- (ii) $\{x \mid \sqrt{x} \text{ is a whole number less than or equal to } 3\}$

Solution: (i) $\{5, 7, 9, 11\}$ (ii) $\{0, 1, 4, 9\}$.

Example 5: Write the following sets in roster as well as set builder form.

- (i) Real numbers between 2 and 5.
- (ii) Fractions whose numerator and denominator are natural numbers and denominator exceeds the numerator by 1.

Is it possible to write in both the forms?

Solution: (i) Real numbers between 2 and 5.

Roster Form: Not possible to write the set in roster form, as we neither know its first element nor its last element. In fact, it's not possible to write two consecutive elements of this set.

Set Builder Form: $\{x : x \in \mathbb{R} \text{ and } 2 < x < 5\}$

(ii) Fractions whose numerator and denominator are natural numbers and denominator exceeds the numerator by 1.

Roster Form: $\left\{\frac{1}{2}, \frac{2}{3}, \frac{3}{4}, \frac{4}{5}, \dots\right\}$

Set Builder Form: $\{x : x = \frac{n}{n+1}, \text{ where } n \in \text{natural number}\}$

Example 6: Use \in or \notin to indicate whether the given object is an element of the given set or not.

(i) $y \dots \{a, x, y, z\}$

(ii) $4 \dots \{1, 2, 5, 7, 11\}$

(iii) $2 \dots \phi$

(iv) $5 \dots \{x : x \text{ is a natural number } \leq 5\}$

Solution: (i) \in (ii) \notin (iii) \notin (iv) \in

Example 7: Write each of the sets given below in the alternative form (roster or set builder)

(i) $\{2, 3, 5, 7, 11\}$

(ii) $\{1, 3, 5, 7, 9, 11\}$

Solution: (i) $\{x : x \text{ is a prime number less than } 12\}$

(ii) $\{x : x \text{ is an odd natural number less than } 13\}$

• **Is the order of elements in a set important?**

The elements of a set distinguish the set – not the order in which the elements are written.

Thus the three sets $\{1, 2, 3\}$, $\{1, 3, 2\}$ and $\{3, 2, 1\}$ are the same set.

• **Can a set have repeated elements?**

Think about it!

Try to form a set containing letters of the word “BANANA”

Is it $\{B, A, N, A, N, A\}$? If it is correct, how many elements does the set contains, 6 or 3.

In fact, repetition of elements is not allowed in a set. A set contains only distinct elements. So the set containing the letters of the word “BANANA” is $\{B, A, N\}$.

Let us define some more type of sets:

1.5 Empty or Null Set

Consider the set $\{x : x \text{ is a prime number which is composite}\}$

Is there a number which is both prime as well as composite?

Since no prime is composite, so the above set can be written in roster form as $\{ \}$.

We say a set which does not contain any element is called an empty, null or void set. An empty set is denoted by the symbol ϕ or $\{ \}$.

Example 8: Which of the following are empty sets:

- (i) Set of even prime numbers.
- (ii) Set of composite numbers having atmost 2 factors.
- (iii) Set of numbers which are both rational and irrational.
- (iv) Set of irrational numbers whose decimal expansion terminates.

Solution:

- (i) $\{2\}$; It is not an empty set.
- (ii) Since a composite number has more than two factors, so it is an empty set.
- (iii) Since no rational number is irrational, so set of numbers which are both rational and irrational is an empty set.
- (iv) The decimal expansion of irrational number is neither terminating nor recurring. So it is an empty set.

1.6 Equality of Sets

Let A and B be two sets. We say $A = B$, if A and B have the same elements.

If two sets A and B are not equal, we write $A \neq B$.

Some example of equal sets are:

$\{2, 5, -1, 0\}$ and $\{0, -1, 5, 2\}$;

$\{1, 2, 2, 2, 7, 7, 7, 7, 7\}$ and $\{1, 2, 7\}$;

$\{x : x \text{ is a prime divisor of } 6\}$ and $\{x : x \text{ is a pair of consecutive numbers that are prime}\}$

EXERCISE 1.1

1. List the elements of the following sets :

- (a) $\{x : x \text{ is an integer and } x^2 = 9\}$
- (b) $\{x : x \text{ is a positive integer less than } 5\}$
- (c) $\{x : x \text{ is even natural number divisible by } 5\}$
- (d) $\{x : x \in \mathbb{N} \text{ and } x < -1\}$

1.7 Subset

Consider the set X of students who live in the vicinity of 5 km radius around your school.

These students obviously along with others belongs to the set Y of all students in your class.

Since every student of set X belongs to or is contained in set Y , we say X is a subset of Y .

Definition: The set A is said to be a subset of B if and only if every element of A is also an element of B .

Symbolically, we write it as $A \subseteq B$.

If A is not a subset of set B , we write it as $A \not\subseteq B$.

We say $A \subseteq B$ if $a \in A \Rightarrow a \in B$.

Note that if A is a subset of B and $A \neq B$, then we say A is a proper subset of B and denote it by $A \subset B$.

- Is an empty set ϕ , a subset of a set containing at least one element, say P ?

Yes, because there is no element in ϕ which is not in P .

Example 9: Use the notation \subseteq to denote which set is the subset of the other in the following problems.

- | | |
|---|--|
| (i) $A = \{2, 3, p\}$ | $B = \{1, 2, 3, p, q\}$ |
| (ii) $A = \{2, 3, 5, 7\}$ | $B = \phi$ |
| (iii) $A = \{3, 8, 9, 0\}$ | $B = \{0, 9, 8, 3\}$ |
| (iv) $A = \{x \mid x = 2n, \text{ where } n \in \mathbb{N}\}$ | $B = \{x \mid x = 4n, \text{ where } n \in \mathbb{N}\}$ |

Solution:

- $A \subseteq B$
- Since ϕ is subset of every set, So $B \subseteq A$
- Since $A = B$, therefore each is a subset of the other i.e., $A \subseteq B$ as well as $B \subseteq A$.
- $A = \{2, 4, 6, 8, 10, 12, \dots\}$
 $B = \{4, 8, 12, 16, 20, \dots\}$
So $B \subseteq A$.

1.8 Cardinality of a Set

Let A be any set. If there are exactly m distinct elements in A , we say, cardinality of set A is m . Symbolically we write it as

$$n(A) = m, \text{ where } m \text{ is a non-negative integer,}$$

For example, if $A = \{1, 2, 3, \dots, 9\}$ then $n(A) = 9$ and if $B = \left\{ \pi, \sqrt{3}, 7\frac{1}{2}, 0 \right\}$ then

$$n(B) = 4.$$

1.9 Power Set

Consider the set $D = \{a, b\}$. Can you write all its subsets?

Are $\{a\}$, $\{b\}$ its only subsets?

A little thinking would suggest some are still left.

It has two more subsets i.e. $\{a, b\}$ and ϕ .

So the set has 4 subsets in all i.e., $\{a\}$, $\{b\}$, $\{a, b\}$, ϕ .

If these subsets are written in a set form, we call it a power set of D .

$$\text{i.e., } P(D) = \{\{a\}, \{b\}, \{a, b\}, \phi\}$$

- Note:**
- $\{a\}$ and $\{a, b\}$ are elements of the set $P(D)$.
 - Neither a , nor a, b taken together are the elements of the set $P(D)$.

Example 10: What is the power set of $A = \{0, 1, 2\}$?

Solution: Since the power set of A is again a set containing all its subsets, so

$$P(A) = \{\phi, \{0\}, \{1\}, \{2\}, \{0, 1\}, \{0, 2\}, \{1, 2\}, \{0, 1, 2\}\}$$

Symbolically, we denote it by $P(A)$.

Example 11: What is the power set of an empty set? What is the power set of $\{\phi\}$?

Solution: Since every set is a subset of itself. So ϕ is a subset of ϕ . Hence $P(\phi) = \{\phi\}$.

Also the set $\{\phi\}$ has exactly two subsets ϕ and $\{\phi\}$ itself hence $P(\{\phi\}) = \{\phi, \{\phi\}\}$.

A set containing n elements has 2^n subsets. If $n(A) = p$, where p is a whole number then $n[P(A)] = 2^p$.

Consider the set $A = \{1, 2\}$ then it has 2^2 i.e., 4 subsets and $2^2 - 1 = 3$ proper subsets (i.e. ϕ , $\{1\}$ and $\{2\}$).

1.10 Universal Set

In sets, the elements that we consider are usually limited to a specific all-encompassing set. For example, when we take sets of students belonging to a class or different sections of the same class or students of an editorial team, they all study in the same school. So the universal set denoted by 'U' are all the students of the school.

Similarly, if we discuss set of natural numbers, rational numbers and irrational numbers, then real numbers is the appropriate universal set. Universal set is denoted by U .

EXERCISE 1.2

1. Fill in the blanks with symbol \subset or $\not\subset$.

(i) $\{2, 3, 4\}$ $\{1, 2, 3, 4, 5\}$

(ii) $\{x \mid x \text{ are triangles in a plane}\}$ $\{x \mid x \text{ are polygons in a plane}\}$

1.12 Set Operations

Two sets can be combined in many different ways. For instance, if we have set of students who play cricket and a set of students who play soccer, then we can form a set of students who play either cricket or soccer. We may also consider students who play both cricket and soccer. This is possible by performing certain operations on two sets to give another set.

Let us study these operations in detail.

1.12.1 Union of Two Sets

Let A and B be any two sets. Then union of A and B is the set containing elements of A or B or both A and B.

Symbolically, $A \cup B = \{x : x \in A \text{ or } x \in B\}$

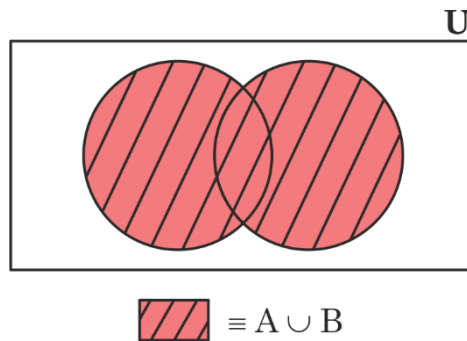

Note: ' $A \cup B$ ' is also denoted by A or B.

Example 12: If $A = \{2, 3, 5, 7\}$ and $B = \{1, 3, 5, 9, 11\}$ find $A \cup B$.

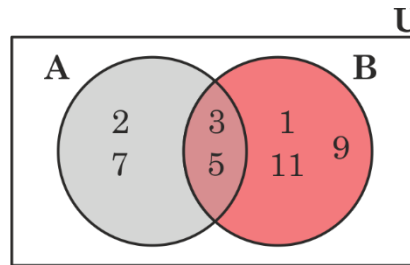

Solution: Since $A \cup B$ consists of all the elements of A as well as B.
Hence, $A \cup B = \{1, 2, 3, 5, 7, 9, 11\}$

Example 13: Find the union of the following pair of sets.

- (i) $A = \{2, 5, 9\}$, $B = \{1, 4, 7\}$
- (ii) $C = \{3, 5, 6\}$, $D = \{3, 4, 5, 6, 9\}$
- (iii) $P = \{a, b, d, e\}$, $Q = \{b, c, e, f, g\}$

Solution:

- (i) $A \cup B = \{1, 2, 4, 5, 7, 9\}$
- (ii) $C \cup D = \{3, 4, 5, 6, 9\}$
- (iii) $P \cup Q = \{a, b, c, d, e, f, g\}$

1.12.2 Intersection of Two Sets

Let A and B be two sets. Then the intersection of A and B is the set that contains elements present in both A and B.

Symbolically, $A \cap B = \{x : x \in A \text{ and } x \in B\}$

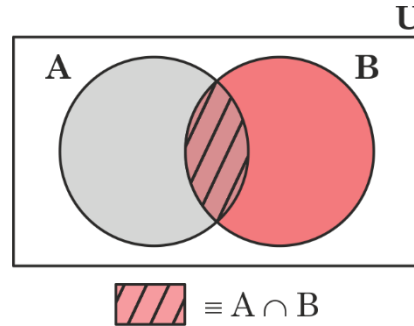

Note: ' $A \cap B$ ' is also denoted by 'A and B'.

Example 14: Find the intersection of the following two sets

$$A = \{2, 3, 5, 7, 9\}$$

$$B = \{3, 5, 9, 11, 13\}$$

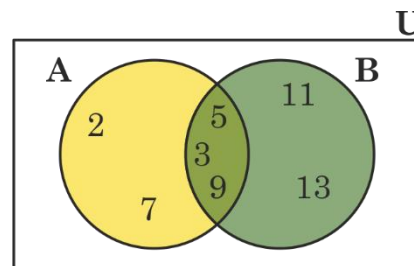

Solution: Since $A \cap B$ consists of elements that are common to A and B.
Hence, $A \cap B = \{3, 5, 9\}$.

Example 15: Find the intersection of the following pairs of sets

(i) $\{a, b, f\}$ and $\{d, e, f, g\}$

(ii) $\{1, 2, 3, 6, 9\}$ and $\{1, 4, 5, 9, 13\}$

(iii) ϕ and $\{c, d, e\}$

(iv) $\{x : x \text{ is a natural number greater than 4 and less than 10}\}$ and
 $\{x : x \text{ is a factor of 12}\}$

Solution: (i) $\{f\}$ (ii) $\{1, 9\}$ (iii) ϕ (iv) $\{6\}$

1.12.3 Disjoint Sets

Two sets A and B are disjoint if they have no element in common.

Therefore, the intersection of two disjoint sets is an empty set

$$A \cap B = \phi$$

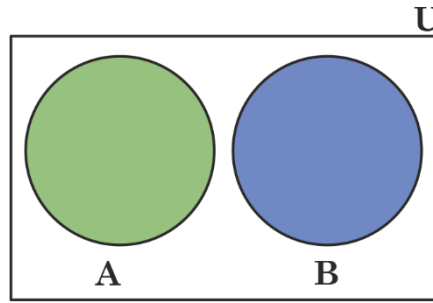

Disjoint Sets

Example 16: Identify pair(s) of disjoint sets from the following:

$$A = \{1, 3, 4\}$$

$$B = \{5, 6, 7, 8, \dots\}$$

$$C = \{x : x \text{ is a prime factor of } 36\}$$

$$D = \{5, 7, 11, 13\}$$

Solution: Since, $A \cap B = \phi$; A, B are disjoint
 $A \cap D = \phi$; A, D are disjoint
 $C \cap D = \phi$; C, D are disjoint.

1.12.4 Difference of Sets

Let A and B be two sets. The difference of A and B, denoted by $A - B$ is the set containing elements which are in A but not in B.

Symbolically, $A - B = \{x : x \in A \text{ and } x \notin B\}$

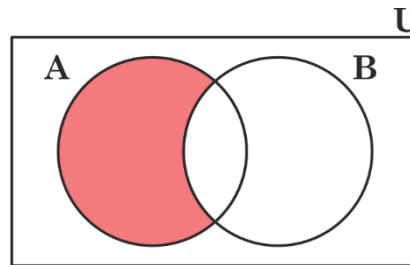

$$\text{Red shaded region} \equiv A - B$$

The difference of $\{2, 5, 7\}$ and $\{1, 2, 4\}$ is $\{5, 7\}$.

Example 17: Find the difference of A and B from the following pair of sets.

$$(i) A = \{1, 3, 5, 7, 9\},$$

$$B = \{2, 6, 8\}$$

$$(ii) A = \{a, b, p, q\},$$

$$B = \{b, q\}$$

$$(iii) A = \{1, 5, 9\},$$

$$B = \{1, 2, 4, 5, 7, 9\}$$

Solution: (i) $A - B = \{1, 3, 5, 7, 9\}$
(ii) $A - B = \{a, p\}$
(iii) $A - B = \phi$

1.13 Complement of a Set

Let us learn complement of a set by taking a simple example.

Consider the students of your class as universal set. Let A be the set of boys in the class and B be the set of girls in the class. Then complement of boys is the set of students other than the boys i.e. the girls. Let us give the formal definition of the complement.

Definition of Complement

The complement of set A denoted by A' is defined by $A' = \{x : x \in U \text{ and } x \notin A\}$

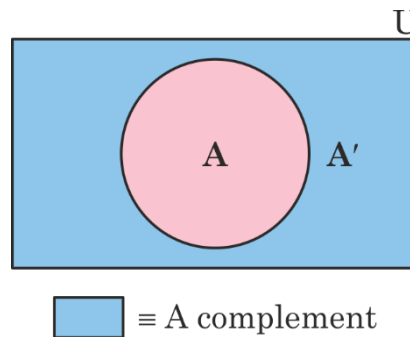

Example 18: Given,

$$U = \{x \in \mathbb{N} : x \leq 9\}$$

$$A = \{1, 2, 7\}$$

$$B = \{1, 6, 8, 9\}$$

find the following:

- (a) A' (b) B' (c) $(A \cup B)'$ (d) $A' \cap B'$

Solution: $U = \{1, 2, 3, 4, 5, 6, 7, 8, 9\}$

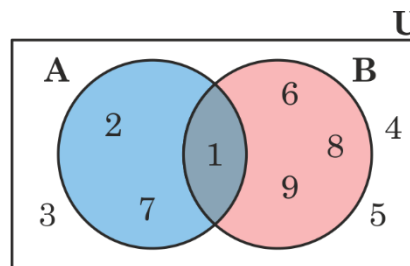

- (a) $A' = \{3, 4, 5, 6, 8, 9\}$
 (b) $B' = \{2, 3, 4, 5, 7\}$
 (c) $(A \cup B)' = \{1, 2, 6, 7, 8, 9\}' = \{3, 4, 5\}$
 (d) $A' \cap B' = \{3, 4, 5, 6, 8, 9\} \cap \{2, 3, 4, 5, 7\} = \{3, 4, 5\}$

Note that $(A \cup B)' = A' \cap B'$. This law is known as **De-Morgan's Law**.

Example 19: Given $A = \{1, 3, 5, 8, 9\}$, $B = \{2, 3, 4, 7, 9, 13\}$
and $U = \{1, 2, 3, 4, 5, 6, 7, 8, 9, 11, 13, 15\}$

Use Venn diagram to verify the following De-Morgan's Laws.

(i) $(A \cap B)' = A' \cup B'$ (ii) $(A \cup B)' = A' \cap B'$

Solution: Representing given sets by Venn diagram we get

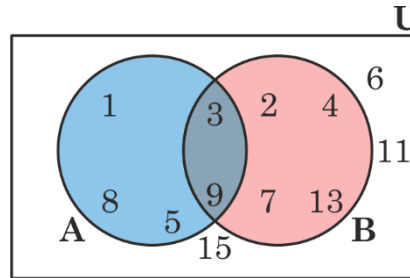

(i) $(A \cap B)' = U - (A \cap B) = \{1, 2, 4, 5, 6, 7, 8, 11, 13, 15\}$
 $A' \cup B' = \{2, 4, 6, 7, 11, 13, 15\} \cup \{1, 5, 6, 8, 11, 15\}$
 $= \{1, 2, 4, 5, 6, 7, 8, 11, 13, 15\}$

Hence, $(A \cap B)' = A' \cup B'$

(ii) $(A \cup B)' = U - (A \cup B) = \{6, 11, 15\}$
 $A' \cap B' = \{2, 4, 6, 7, 11, 13, 15\} \cap \{1, 5, 6, 8, 11, 15\}$
 $= \{6, 11, 15\}$

Hence, $(A \cup B)' = A' \cap B'$

1.14 Application of Sets

The concept of cardinal number finds many practical applications in real life. The theory of sets and the operations on them, provides some very useful formulae.

Let us now discuss and enlist a few observations which can be very easily verified using Venn diagrams.

1.14.1 If A and B are two finite sets, then their cardinal numbers are related as below:

1. $n(\text{Either in A or in B}) = n(A \cup B) = n(A) + n(B) - n(A \cap B)$
2. $n(\text{Only in A, not in B}) = n(A - B) = n(A) - n(A \cap B)$
3. $n(\text{Neither in A nor in B}) = n(A' \cap B') = n(A \cup B)' = n(U) - n(A \cup B)$
4. $n(\text{Only in one of them}) = n[(A - B) \cup (B - A)] = n(A) + n(B) - 2n(A \cap B)$

Example 20: In a class with 40 students, 22 play badminton, 11 play both badminton and table tennis and 16 play neither badminton nor table tennis. How many play table tennis but not badminton?

Solution:

Let B represents the set of students who play badminton and T represents the set of students who play table tennis.

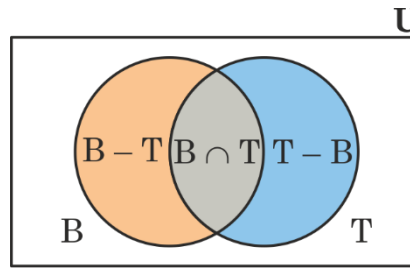

We are given, $n(U) = 40$, $n(B) = 22$, $n(B \cap T) = 11$, $n(B \cup T)' = 16$

$$n(B \cup T) = n(U) - n(B \cup T)' = 40 - 16 = 24$$

Now, $n(B \cup T) = n(B) + n(T) - n(B \cap T)$

i.e., $24 = 22 + P(T) - 11$

or $24 = 11 + P(T)$

$$P(T) = 13 \text{ i.e. } 13 \text{ students play table tennis}$$

$n(\text{Play table tennis but not badminton})$

$$= n(T) - n(B \cap T)$$

$$= 13 - 11 = 2 \text{ students}$$

2 students play table tennis but not badminton.

Example 21: Each student from a group of 120 university students participated in teaching either a language or mathematics to the needy students. It is found that 92 of them can teach a language to the needy students and 46 can teach mathematics.

- Find the number of students who can teach both the subjects.
- Find the number of students who can teach only one of the two subjects.

Solution:

If L denotes the set of students who can teach a language, M denotes the set of students who can teach mathematics

$$n(L) = 92, n(M) = 46 \text{ and } n(L \cup M) = 120$$

Applying the relation

$$(a) \quad n(\text{Either in L or in M}) = n(L \cup M)$$

$$= n(L) + n(M) - n(L \cap M) \text{ we get}$$

$$n(L \cap M) = n(L) + n(M) - n(L \cup M)$$

$$= 92 + 46 - 120$$

$$= 18$$

Therefore 18 students can teach both the subjects.

$$\begin{aligned}
 \text{(b) } n(\text{Exactly in one of them}) &= n[(L - M) \cup (M - L)] \\
 &= n(L) + n(M) - 2n(L \cap M) \\
 &= 92 + 46 - 2 \times 18 \\
 &= 138 - 36 \\
 &= 102
 \end{aligned}$$

Therefore 102 students can teach only one of the two subjects.

Note: You can also use the Venn diagram to solve this example.

Example 22: In a survey of 100 students regarding their preference for two subjects—Physics (P) and Chemistry (C), it is observed that 70 preferred Physics and 60 preferred Chemistry.

- (i) Find the maximum possible number of students who neither like Physics nor Chemistry.
- (ii) Find the minimum possible number of students who like both Physics and Chemistry.

Solution: We know that, $n(P \cup C) = n(P) + n(C) - n(P \cap C)$

- (i) For maximum number of students who like neither of the subjects, we need $(P \cup C)'$

$n((P \cup C)') = n(U) - n(P \cup C)$ will be maximum if $n(P \cup C)$ is minimum. This happens when one of the two sets is a subset of the other, so that $P \cap C$ becomes the maximum.

The maximum possible value of $n(P \cap C)$ is the cardinal number of the smaller set, which is 60. (Means if everyone who likes Chemistry also likes Physics).

Thus, Minimum $n(P \cap C) = 70 + 60 - 60 = 70$.

Therefore, maximum number of students who neither like Physics nor Chemistry = $100 - 70 = 30$

- (ii) We know that $n(P \cup C) \leq n(U)$

This means $70 + 60 - n(P \cap C) \leq 100$

Therefore, $n(P \cap C) \geq 30$

Thus the minimum possible number of students who like both Physics and Chemistry is 30.

Alternate solution:

Let x be the number of students who like neither Physics nor Chemistry. These students sit outside the two circles but inside the rectangular Universal set (U).

So on the basis of information the following Venn diagram is drawn.

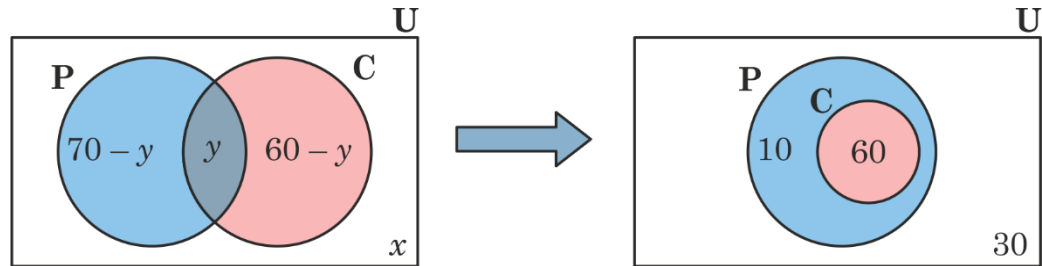

- (i) Thus, to make x as large as possible, we must make the “space” occupied by the circles ($P \cup C$) as small as possible. To make the union of two circles small, we must overlap them as much as possible. The most they can possibly overlap is the size of the smaller set. So, we put all 60 Chemistry students inside the Physics circle.

Therefore, Maximum value of neither Physics nor Chemistry = 30

- (ii) Since $n(P \cup C) = n(P) + n(C) - n(P \cap C)$
 $n(P \cap C) = n(P) + n(C) - n(P \cup C)$

Now $n(P \cap C)$ will be minimum if $n(P \cup C)$ is maximum.

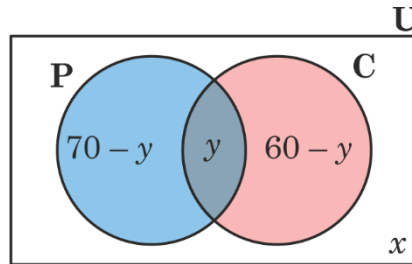

The maximum possible value of $n(P \cup C) = 100$ (as there are a total of 100 students).

Hence, minimum value of $n(P \cap C)$

$$= n(P) + n(C) - n(P \cup C)$$

$$= 70 + 60 - 100 = 30$$

1.14.2 If A, B and C are three finite sets, then the relation between the cardinal numbers is given below:

$$n(A \cup B \cup C) = n(A) + n(B) + n(C) - [n(A \cap B) + n(B \cap C) + n(C \cap A)] + n(A \cap B \cap C)$$

Example 23: A market research group conducted an online survey of 1000 consumers and found that 35% of the consumers had rated a shampoo of type A by 5-stars. While 30% of the consumers rated the shampoo of type B by 5-stars and 250 consumers rated the shampoo of type C

by 5-stars. It was observed that 200 consumers gave 5-star rating to the shampoos of both the types A and B, 150 consumers gave it to the shampoos of both the types B and C and 150 gave a 5-star to both A and C and 100 consumers rated all of them with 5-star.

- (i) Find the percentage of consumers who gave 5-star rating to only one type of shampoo.
- (ii) Find the number of consumers who did not give 5-star rating to any of the shampoos.

Solution:

Let A, B and C represent the sets of consumers who rated 5-stars to the shampoos A, B and C respectively. We observe

$$\begin{aligned} n(U) &= 1000; & n(A) &= 30\% \text{ of } 1000 = 350; \\ n(B) &= 30\% \text{ of } 1000 = 300 & \text{and} & n(C) = 250 \\ n(A \cap B) &= 200; & n(B \cap C) &= 150; \\ n(A \cap C) &= 15\% \text{ of } 1000 = 150 & \text{and} & n(A \cap B \cap C) = 100 \end{aligned}$$

Using Venn diagram we find:

$$n(\text{only in A and B}) = n(A \cap B) - n(A \cap B \cap C) = 200 - 100 = 100$$

$$n(\text{only in B and C}) = n(B \cap C) - n(A \cap B \cap C) = 150 - 100 = 50$$

$$n(\text{only in A and C}) = n(A \cap C) - n(A \cap B \cap C) = 150 - 100 = 50$$

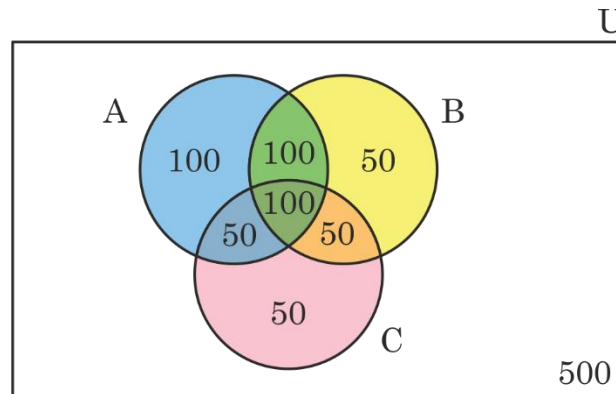

- (i) Thus, from Venn diagram, Number of consumers who gave 5-star rating to only one type of shampoo = $100 + 50 + 50 = 200$
So, percentage of consumers who gave 5-star rating to only one type of shampoo

$$= \frac{200}{1000} \times 100 = 20\%$$

- (ii) Now, number of consumers who did not give 5-star rating to any of the shampoos $n(U) - n(A \cup B \cup C) = 1000 - 500 = 500$

EXERCISE 1.3

- Find the union of sets A and B i.e. $A \cup B$, in each of the following pairs.
 - $A = \{1, 2, 3, 7\}$, $B = \{2, 7, 9\}$
 - $A = \{a, b, d, e\}$, $B = \{a, e, i, o, u\}$
 - $A = \{x : x \text{ is natural number} > 5\}$, $B = \{x : x \text{ is natural number} < 5\}$
 - $A = \phi$, $B = \{2, \sqrt{2}, -1, 0\}$
- Evaluate each of the following.
 - $\{1, 2\} \cap \{1, 2, 5\}$
 - $\{1, 3, 5, 7, 9\} \cap \{2, 4, 6, 8\}$
 - $\{g, o, a, t\} \cap \{c, a, t\}$
 - $\{x : x \text{ is an integer}\} \cap \{x : x \text{ is a negative integer}\}$
- Which of the following sets are disjoint?
 - $\{x : x \text{ is a multiple of } 2\}$ and $\{x : x \text{ is a multiple of } 3\}$
 - $\{e, \pi, \sqrt{2}, 0\}$ and $\{e^2, \frac{\pi}{2}, \sqrt{3}, 1\}$
 - $\{x : x \text{ is a real number}\}$ and $\{x : x \text{ is an irrational number}\}$
- Find $A - B$ in each of the following.
 - $A = \{1, 3, 5, 8\}$, $B = \{3, 7, 8, 9\}$
 - $A = \{3, 0, 8\}$, $B = \{1, 3, 0, 8, 9\}$
 - $A = \{2, 6\}$, $B = \{1, 3, 5, 9\}$
- Use the Venn diagram given below to answer the questions that follow.

Hint: You can find sets A, B, C and universal set U from the given Venn diagram.

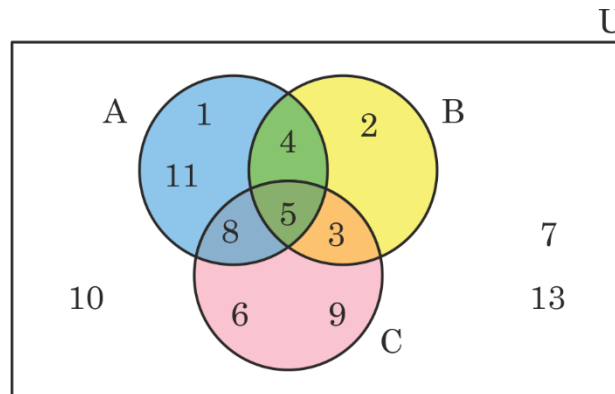

(i) A'

(ii) B'

(iii) $(A \cap B)'$

(iv) $A' \cup B'$

(v) $A \cap B \cap C$

(vi) $A \cap (B \cup C)$

6. Verify $A - B = A \cap B'$ using the Venn diagram given below:

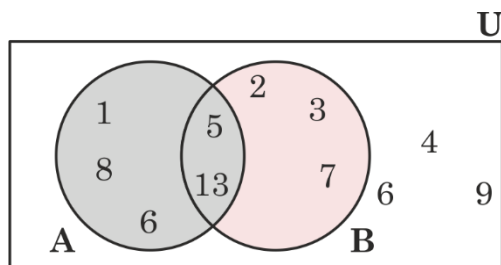

7. For a competitive exam, 85% of students opted for a Mock Test in Mathematics and 75% opted for a Mock Test in Science.
- What is the minimum possible percentage of students who opted for both tests?
 - If 10% opted for neither, how does the minimum percentage for both change?
8. Let S be a set of 50 people. 35 people speak English and 25 speak Hindi. If k be the number of people who speak only English, then find the possible value of k , assuming every person speaks at least one of the two languages.
9. An organization awarded certificates to its 56 students for at least one of the three activities of Origami, Instrumental music and Fine arts. If 17 students received the certificates for Origami, 28 for Instrumental music, 25 for Fine arts and only 4 students got the certificates for all the three activities. Find the number of students who received the certificates for exactly two activities.
10. A survey of a group of 100 students in an international school revealed that 60 students could speak English, 50 students could speak German and 35 students could speak Spanish. Further 40 students could speak both English and German, 30 could speak both German and Spanish, 25 could speak both English and Spanish and 25 could speak all the three languages. Let E represent the set of students who speak English, G represents the set of students who speak German and S represent the set of students who speak Spanish. Answer the following using Venn diagram.
- How many students could speak at least two languages?
 - How many students could speak at most one language?
 - How many students could not speak any of the three languages?

Summary

- (1) A set is a well-defined collection of objects.
- (2) A set is represented in two forms
 - Roster Form
 - Set-Builder Form
- (3) A set is finite if its number of elements is a natural number. Else it is infinite.
- (4) A is subset of B if every element of A is contained in B. Symbolically it is denoted by $A \subseteq B$.
- (5) **Cardinality** of a set is the number of distinct elements in it. It is denoted by $n(A)$.
- (6) The set of all subsets of a set A is called **power set** of A and is denoted by $P(A)$.
- (7) **Operation of sets.**
 - **Union** of sets A and B is a set containing elements of A or elements of B or both. It is denoted by $A \cup B$.
 - **Intersection** of sets A and B is a set containing elements of A and B. It is denoted by $A \cap B$.

- (8) **Disjoint sets**

Two sets A and B are said to be disjoint if their intersection is an empty set

$$\text{i.e., } A \cap B = \phi$$

- (9) **Difference** of two sets A and B is a set containing elements of A which are not in B

$$\text{i.e., } A - B = \{x : x \in A \text{ and } x \notin B\}$$

- (10) **Complement** of a set A with respect to universal set U is a set containing the elements of U which are outside A

$$\text{i.e., } A' = U - A.$$

- (11) **Applications of Sets using cardinal relations and Venn diagrams**

11.1 If A and B are two finite sets, then their cardinal numbers are related as below:

- $n(A \cup B) = n(A) + n(B) - n(A \cap B)$
- $n(A - B) = n(A) - n(A \cap B)$
- $n(A' \cap B') = n(A \cup B)' = n(U) - n(A \cup B)$
- $n((A - B) \cup (B - A)) = n(A) + n(B) - 2n(A \cap B)$

11.2 If A, B and C are three finite sets, then their cardinal numbers are related as follows:

$$n(A \cup B \cup C) = n(A) + n(B) + n(C) - [n(A \cap B) + n(B \cap C) + n(C \cap A)] + n(A \cap B \cap C)$$

Logarithms

2.1 Introduction to Logarithms

Imagine a world before calculators and computers when mathematicians had to do complex calculations involving multiplication and division of large numbers. It took tremendous time and effort often involving lengthy calculations.

Opening Puzzle: The Sound of Numbers

In a music studio, the sound engineer says:

“This speaker produces a sound that is 1000 times more intense than the softest sound we can hear.”

Instead of saying “1000 times,” scientists say:

Sound Level = $\log_{10} 1000 = 3$

Why 3?

Because: $10^3 = 1000$

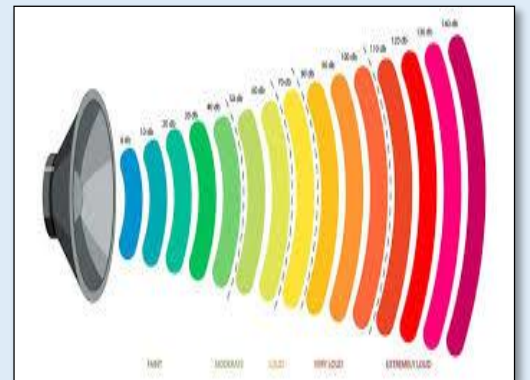

Then came **John Napier** with a revolutionary idea of effectively turning “multiplication into addition,” and “division into subtraction” using logarithms. Logarithms is a tool that helps to do large calculations easily.

This approach saved scientists and fellow mathematicians a lot of tedious calculations.

Logarithms were introduced by John Napier (1550–1617), a Scottish mathematician. His method was different from the modern approach and was based on the relationship between arithmetic and geometric sequences. Later, Henry Briggs refined this idea and developed common logarithms (base 10), which made calculations easier.

Logarithm tables were widely used in science and engineering to simplify multiplication and division until electronic calculators became common. Even today, logarithms remain important in mathematics, especially natural logarithms (base e), which are widely used in calculus.

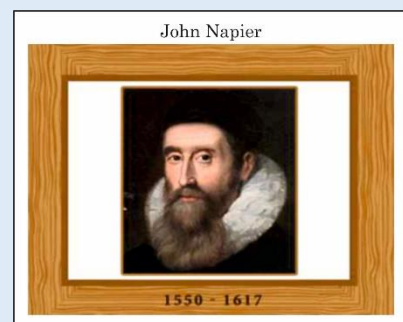

2.2 Understanding Logarithms as the Inverse of Exponents

We have earlier learnt about squares and cubes. For example:

- $10^2 = 100$ (10 squared is 100)
- $10^3 = 1000$ (10 cubed is 1000)

In these cases, we have taken the **base** 10, their **exponents** as 2 and 3. We find the value of base raised to the given exponent. But what if we know the resultant value and the base, and we want to find the exponent?

This power or exponent to which the base is raised is called a **Logarithm**.

- **Exponential Form:** $10^x = 100$
- **Logarithmic Form:** $\log_{10} 100 = x$

We already know about **exponents**: $2^3 = 8$

This means:

- Base = 2
- Exponent = 3
- Resultant = 8

Let us ask a different question: **2 raised to what power gives 8?**

That power is 3. So we say that logarithm of 8 to the base 2 is 3.

2.2.1 Understanding Logarithms through powers of 10

Let us look at powers of 10:

| Powers of 10 | Expressed in logarithmic form: |
|--------------------|--------------------------------|
| $10^0 = 1$ | $\log_{10} 1 = 0$ |
| $10^1 = 10$ | $\log_{10} 10 = 1$ |
| $10^2 = 100$ | $\log_{10} 100 = 2$ |
| $10^3 = 1000$ | $\log_{10} 1000 = 3$ |
| $10^4 = 10000$ | $\log_{10} 10000 = 4$ |
| $10^{-4} = 0.0001$ | $\log_{10} 0.0001 = -4$ |
| $10^{-3} = 0.001$ | $\log_{10} 0.001 = -3$ |
| $10^{-2} = 0.01$ | $\log_{10} 0.01 = -2$ |
| $10^{-1} = 0.1$ | $\log_{10} 0.1 = -1$ |
| $10^0 = 1$ | $\log_{10} 1 = 0$ |

2.3 Logarithms Properties

The definition and the assumptions of logarithm are as follows:

Definition of Logarithm:

For $a > 0$, $a \neq 1$ and $x > 0$,

If $y = \log_a x$, then $a^y = x$.

Equivalently, $\log_a x = y \Leftrightarrow a^y = x$.

Assumptions:

- $a > 0$, $a \neq 1$ (The Base)
- $M > 0$, $N > 0$ (Positive real number)

These conditions ensure all logarithms in the following proofs, are defined.

Properties of Logarithms

Product Rule

Statement: $\log_a(MN) = \log_a M + \log_a N$

Proof: Let $x = \log_a(MN)$, $y = \log_a M$, $z = \log_a N$

Then, $a^x = MN$, $a^y = M$ and $a^z = N$

Therefore, $a^{y+z} = a^y a^z = MN \Rightarrow y+z = \log_a(MN)$

Thus, $\log_a M + \log_a N = \log_a(MN)$

Quotient Rule

Statement: $\log_a\left(\frac{M}{N}\right) = \log_a M - \log_a N$

Proof: Let $x = \log_a\left(\frac{M}{N}\right)$, $y = \log_a M$, $z = \log_a N$

Then, $a^x = \left(\frac{M}{N}\right)$, $a^y = M$ and $a^z = N$

Therefore, $a^{y-z} = \frac{a^y}{a^z} = \left(\frac{M}{N}\right) \Rightarrow y-z = \log_a\left(\frac{M}{N}\right)$

Thus, $\log_a M - \log_a N = \log_a\left(\frac{M}{N}\right)$

Power Rule

Statement: $\log_a(M^k) = k\log_a M$

Proof: Let $x = \log_a(M^k)$ and $y = \log_a M$

Then, $a^x = M^k$, $a^y = M$

Therefore, $a^x = a^{ky} \Rightarrow x = ky$

Thus, $\log_a(M^k) = k\log_a M$

Change of Base Formula

Statement: $\log_a(M) = \frac{\log_b M}{\log_b(a)}$, For $b > 0$, $b \neq 1$

Proof: Let $x = \log_a(M) \Rightarrow a^x = M$

Now take log with base b on both the sides,

$\log_b(a^x) = \log_b M \Rightarrow x \log_b a = \log_b M$

Thus, $x = \log_a(M) = \frac{\log_b(M)}{\log_b(a)}$

Log of 1

Statement: $\log_a(1) = 0$

Proof: Let $x = \log_a 1 \Rightarrow a^x = 1$

Since, $a^0 = 1$, for any $a > 0$, $a \neq 1$

$a^0 = 1 = a^x \Rightarrow x = 0$

Thus, $x = \log_a(1) = 0$

Log of a number to the same base

Statement: $\log_a a = 1$

Proof: Let $x = \log_a a \Rightarrow a^x = a$

Since, $a^1 = a$, for any $a > 0$, $a \neq 1$

$a^1 = a^x \Rightarrow x = 1$

Thus, $x = \log_a a = 1$

Let us summarize the properties of logarithms we proved above in the table below:

For any base a , $a > 0$, $a \neq 1$ and $M, N > 0$

| Property Name | Logarithmic Notation | What it does |
|--------------------------------|---|--|
| Product Rule | $\log_a (M \times N) = \log_a M + \log_a N$ | Turns multiplication into addition |
| Quotient Rule | $\log_a \left(\frac{M}{N} \right) = \log_a M - \log_a N$ | Turns division into subtraction |
| Power Rule | $\log_a (M^k) = k \times \log_a M$ | The exponent comes down |
| log of number to the same base | $\log_a (a) = 1$ | Log of any number to the same base is 1 |
| log of 1 | $\log_a (1) = 0$ | Logarithm of 1 to any base is zero |
| Base changing property | $\log_a n = \frac{\log_b n}{\log_b a}$ | Base a is changed to any other base b ($b > 0$ and $b \neq 1$) |

Remember: For positive values of m, n, x, y and $a > 0, a \neq 1$,

- $\log_a (m+n) \neq \log_a m + \log_a n$
- $\log_a (m-n) \neq \log_a m - \log_a n$
- If $x \neq y$ then $\log_a x \neq \log_a y$

Example 3: Write it as a single logarithm

(a) $\log_7 3 + \log_7 5$

(b) $\log_2 9 - \log_2 3$

(c) $\log_4 3 + \log_4 6 - 3\log_4 2$

(d) $1 + \log_3 5$

Solution:

$$\begin{aligned} \text{(a)} \quad \log_7 3 + \log_7 5 &= \log_7 (3 \times 5) \\ &= \log_7 15 \end{aligned}$$

$$\begin{aligned} \text{(b)} \quad \log_2 9 - \log_2 3 &= \log_2 \left(\frac{9}{3} \right) \\ &= \log_2 3 \end{aligned}$$

$$\begin{aligned}
 \text{(c)} \quad \log_4 3 + \log_4 6 - 3\log_4 2 &= \log_4 (3 \times 6) - \log_4 2^3 \\
 &= \log_4 (18) - \log_4 8 \\
 &= \log_4 \left(\frac{18}{8} \right) \\
 &= \log_4 \left(\frac{9}{4} \right)
 \end{aligned}$$

$$\begin{aligned}
 \text{(d)} \quad 1 + \log_3 5 &= \log_3 (3) + \log_3 5 \\
 &= \log_3 (3 \times 5) \\
 &= \log_3 15
 \end{aligned}$$

Example 4: Find the value of:

(a) $\log_7 343$

(b) $\log_3 27\sqrt{3}$

Solution:

$$\begin{aligned}
 \text{(a)} \quad \log_7 343 &= \log_7 (7^3) \\
 &= 3\log_7 (7) = 3
 \end{aligned}$$

$$\begin{aligned}
 \text{(b)} \quad \log_3 27\sqrt{3} &= \log_3 \left(3^3 \times 3^{\frac{1}{2}} \right) \\
 &= \log_3 3^{\left(3 + \frac{1}{2} \right)} \\
 &= \log_3 3^{\left(\frac{7}{2} \right)} = \frac{7}{2}
 \end{aligned}$$

Example 5: Simplify: $\log_3 81 - \log_3 9$

$$\begin{aligned}
 \text{Solution:} \quad \log_3 81 - \log_3 9 &= \log_3 3^4 - \log_3 3^2 \\
 &= 4\log_3 3 - 2\log_3 3 \\
 &= 4 - 2 = 2
 \end{aligned}$$

2.4 Logarithm to base 10

Logarithms in base 10 are called **common logarithm** as they are used in many common scales, such as the **Richter scale** for measuring the magnitude of earthquakes, the **pH scale** for measuring acidity or alkalinity and the **decibel scale** for measuring sound.

$\log_{10} x$ is often written as just $\log x$, and we *assume* the logarithm has base 10.

Rules of common logarithms:

The rules of common logarithm given below are similar to the one derived earlier:

- $\log(xy) = \log x + \log y$
- $\log\left(\frac{x}{y}\right) = \log x - \log y$
- $\log(x^n) = n \times \log x$
- $\log 1 = 0$
- $\log 10 = 1$

Example 6: Express the following as a single logarithm

(a) $\log 2 + \log 7$

(b) $\log 6 - \log 3$

Solution:

(a) $\log 2 + \log 7 = \log (2 \times 7)$
 $= \log 14$

(b) $\log 6 - \log 3 = \log \frac{6}{3}$
 $= \log 2$

Example 7: If $\log_3 7 = a$ and $\log_3 4 = b$. Write the following in terms of a and b .

(a) $\log_3\left(\frac{4}{7}\right)$

(b) $\log_3 28$

(c) $\log_3\left(\frac{7}{3}\right)$

Solution:

(a) $\log_3\left(\frac{4}{7}\right) = \log_3 4 - \log_3 7 = b - a.$

(b) $\log_3 28 = \log_3 (4 \times 7) = \log_3 4 + \log_3 7 = b + a.$

(c) $\log_3\left(\frac{7}{3}\right) = \log_3 7 - \log_3 3 = a - 1.$

Example 8: Express the following as a single logarithm:

(a) $3 - \log_2 5$

(b) $1 + \log 2$

Solution:

(a) $3 - \log_2 5 = 3 \times 1 - \log_2 5$

Substituting $\log_2 2 = 1$ we get

$$\begin{aligned} 3 - \log_2 5 &= 3 \times \log_2 2 - \log_2 5 \\ &= \log_2 2^3 - \log_2 5 \end{aligned}$$

$$= \log_2 8 - \log_2 5$$

$$= \log_2 \frac{8}{5}.$$

$$(b) \quad 1 + \log 2 = \log 10 + \log 2 \quad (\text{as } \log_{10} 10 = 1)$$

$$= \log (10 \times 2)$$

$$= \log 20$$

Note:

- Common logarithms have an interesting property of scaling positive numbers that are very small or very large. For example if a certain quantity can take values from 0.0000000001 to 10,000,000,000 then the common logarithms of these numbers would lie in range -10 to 10 .
- Natural logarithm are logarithm to the base e ($2 < e < 3$), where e like π is an irrational number. The natural logarithm are denoted by \ln i.e., $\log_e x = \ln x$.

EXERCISE 2.2

1. Express the following as a single logarithm:

(a) $\log 2 + 2 \log 7$

(b) $\log_3 8 + \log_3 5 - \log_3 4$

(c) $\log 5 + 2 \log 3 - \log 15$

(d) $2 + 2 \log_5 3$

(e) $3 - \frac{1}{2} \log_3 9$

(f) $1 + 2 \log_4 3 - 3 \log_4 4$

2. Find the exact value of

(a) $\log_{11} 121$

(b) $\log_7 1$

(c) $\log_5 625$

(d) $\log_8 8$

(e) $\log 1000$

3. If $\log_2 3 = p$ and $\log_2 5 = q$. Write the following in terms of p and q

(a) $\log_2 15$

(b) $\log_2 45$

(c) $\log_2 \left(\frac{5}{3} \right)$

(d) $\log_2 10$

4. Which of the following are true?

(a) If $2^{x+1} = 3^{x+2}$ then $x + 1 = x + 2$

(b) $\log (x + 1) = \log x$

(c) $\log_b b^3 = 3$

(d) Logarithm to base 1 is not defined.

5. If $\log_{2026} x - \log_{2026} y = a$, $\log_{2026} y - \log_{2026} z = b$ and $\log_{2026} z - \log_{2026} x = c$,

then find the value of $\left(\frac{x}{y} \right)^{b-c} \times \left(\frac{y}{z} \right)^{c-a} \times \left(\frac{z}{x} \right)^{a-b}$.

2.5 Logarithms Across Subjects

Logarithms are the “mathematical tools” used in Science, Music, and even Social science to manage scales that grow too fast such as population or earthquakes.

1. **Chemistry (The pH Scale):** Scientists measure how acidic a liquid is using the concentration of Hydrogen ions. Because these numbers are very small (like 0.00001), they use a negative log scale:

$$\text{pH} = -\log_{10}[\text{H}^+]$$

pH

$[\text{H}^+] = 1.0 \times 10^{-7}$

$\text{pH} = -\log[\text{H}^+]$

pH = 7



2. **Music (The Octave):** When a musician goes up one octave, the frequency of the sound doubles ($2^1, 2^2, 2^3$) but we perceive it as equal steps (1, 2, 3). It is interesting to learn that our ears hear sound logarithmically.

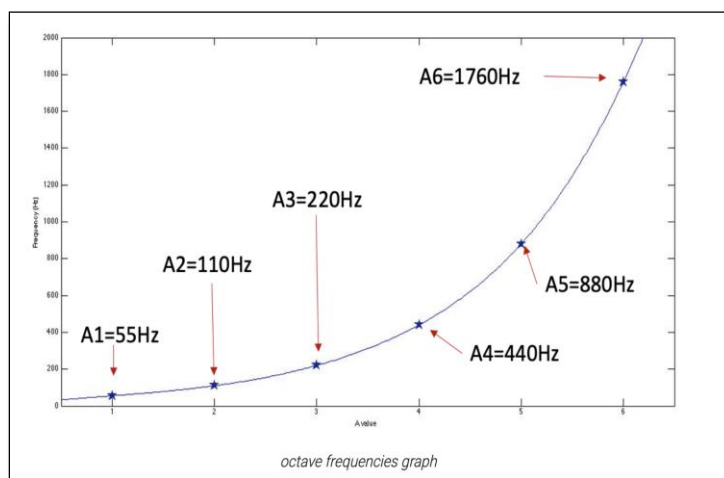

The above graph shows all the A-note octaves from A1 to A6.

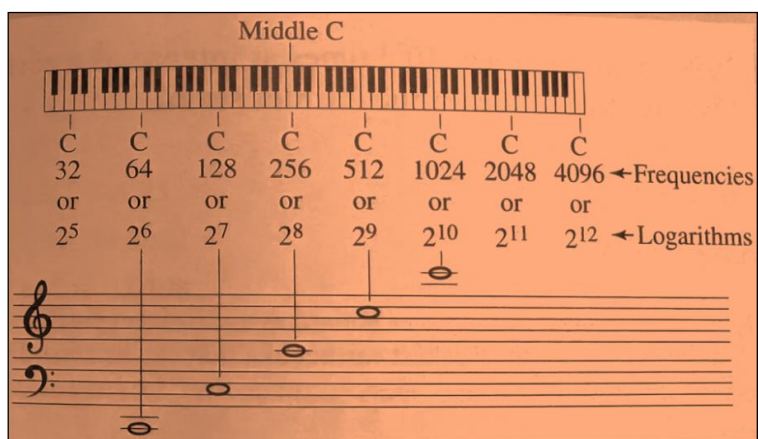

Note that frequency of each C note is written as powers of 2.

3. **Social Science:** Population growth often follows exponential patterns: $P = P_0(1+r)^t$. Logarithms help calculate **time required for population to double**.

4. **Geography (Earthquakes):** The Richter scale used to measure earthquakes is logarithmic. A magnitude 7 earthquake is not “two units” stronger than a magnitude 5 earthquake; it is 10^2 (100 times) more intense in amplitude!

Example 9: An earthquake measures 2 on the Richter scale, while another earthquake measures 5 on the same scale. How many times stronger is the second earthquake than the first?

Solution: Richter scale difference:

$$5 - 2 = 3$$

On the Richter scale, each 1-unit increase means **10 times stronger**.

So a 3-unit increase means:

$$10^3 = 1000$$

The magnitude 5 earthquake is **1000 times** stronger than the magnitude 2 earthquake.

EXERCISE 2.3

1. Express the following in logarithmic form:

(a) $5^4 = 625$

(b) $10^{-2} = 0.01$

(c) $7^0 = 1$

(d) $8^1 = 8$

2. Using the properties of logs, simplify: $\log_2 16 + \log_2 4$

3. Evaluate:

(a) $\log_2 256$

(b) $\log_4 16$

(c) $\log_5 125$

(d) $\log_{10} 0.001$

4. If $\log_2 7 = p$ and $\log_2 3 = q$. Write in terms of p and q .

(a) $\log_2 21$

(b) $\log_2 49$

(c) $\log_2 \left(\frac{7}{3}\right)$

(d) $\log_2 63$

5. Real-world Application:

(a) If a star is 100 times brighter than another, and the difference in their magnitudes is given by $2.5 \times \log_{10}(\text{brightness ratio})$, find the magnitude difference.

- (b) A solution has pH 3 and another has pH 6. How many times more acidic is the first solution? ($\text{pH} = -\log_{10}[\text{H}^+]$)
- (c) A magnitude 9 earthquake occurs on the Richter Scale. How many times stronger is it than a magnitude 4 earthquake?
6. **True or False:** (Explain your reasoning)
- (a) $\frac{1}{3}\log_b x = \sqrt[3]{x}; x > 0$
- (b) $\log_8 e = \frac{1}{\ln 8}$
- (c) Logarithm of a negative number is defined.
- (d) $\log_b(M+N) = \log_b M + \log_b N$
- (e) The base of the logarithm can be any real number.
7. Which is the greatest integer that is less than the number $\log_4 9 + \log_9 28$? (Do not use calculator)
8. Evaluate the value of $(x + 5y)$, where, $x = \log_{1.43}\left(\frac{43}{40}\right)$ and $y = \left(\frac{1}{2}\right)^{\log_2 5}$.

2.6 Solving Logarithmic Equations: The Search for ‘x’

In our journey through logarithms, we have seen how they help us rethink the relationship between numbers and exponents. However, the true power of a logarithm is revealed when it becomes an active tool for solving equations where the unknown value, x , is trapped within a logarithm or a base.

Solving a logarithmic equation is much like being a mathematical detective. You must use the Product, Quotient, and Power rules to combine multiple logarithms into a single expression, and then convert it into its exponential form to find the value of the variable.

The Golden Rule of Logarithmic Equations: You must always verify your solutions! Because the domain of a logarithmic function is strictly positive, the value of $\log_b a$ is defined if a is positive ($a > 0$), and base (b) must be positive and not equal to 1 ($b > 0, b \neq 1$). Sometimes, standard algebraic steps will produce an **extraneous root**—a false solution that mathematically breaks these rules. If substituting your answer back into the original equation results in the logarithm of a negative number or zero, that solution must be rejected.

We will understand this through the following solved examples.

Example 10: Solve for $x : \log_2(3x - 1) = 3$.

Solution: $\log_2(3x - 1) = 3$

Converting logarithmic equation into its exponential form,

$$3x - 1 = 2^3$$

$$\Rightarrow 3x = 9$$

$$\Rightarrow x = 3$$

Check: Substitute $x = 3$ in $\log_2(3x - 1)$ gives $\log_2 8$. Since $8 > 0$, the logarithm is defined.

$\therefore x = 3$ is the required solution.

Example 11: Solve for $x : \log_5 x + \log_5(x - 4) = 1$

Solution: Using the product rule, we get

$$\log_5[x(x - 4)] = 1$$

$$\Rightarrow x(x - 4) = 5^1$$

$$\Rightarrow x^2 - 4x - 5 = 0$$

$$\Rightarrow (x - 5)(x + 1) = 0$$

$$\Rightarrow x = 5, -1$$

Note that on substituting $x = -1$, in the equation gives $\log_5(-1)$ and $\log_5(-5)$. Since log of a negative number is not defined so $x = -1$, is an extraneous root which is rejected.

The only valid solution is $x = 5$.

Example 12: Solve for $x : \log_3(x^2 - 8x) = 2$

Solution: $\log_3(x^2 - 8x) = 2$

Converting logarithmic equation into its exponential form,

$$x^2 - 8x = 3^2$$

$$\Rightarrow x^2 - 8x - 9 = 0$$

$$\Rightarrow (x - 9)(x + 1) = 0$$

$$\Rightarrow x = 9, -1$$

Note that for both $x = 9, -1$, the expression $(x^2 - 8x)$ evaluates to 9, which is strictly greater than zero. Therefore, both $x = 9, -1$ are valid solutions.

Example 13: Solve for x : $\log_2(3x - 4) = \log_2 5$

Solution: $\log_2(3x - 4) = \log_2 5$
 $\Rightarrow 3x - 4 = 5$ (as $\log_a x = \log_a y \Rightarrow x = y$)
 $\Rightarrow 3x = 9$
 $\Rightarrow x = 3$

Example 14: Solve for x : $(\log_3 x)^2 - 5(\log_3 x) + 6 = 0$

Solution: $(\log_3 x)^2 - 5(\log_3 x) + 6 = 0$

Let $y = \log_3 x$, the given equation reduces to

$$y^2 - 5y + 6 = 0$$

$\Rightarrow (y - 3)(y - 2) = 0$
 $\Rightarrow y = 3$ or $y = 2$
 $\therefore \log_3 x = 3$ or $\log_3 x = 2$
 $\Rightarrow x = 3^3$ or $x = 3^2$
i.e. $x = 27, 9$

For both $x = 27$, and $x = 9$, the value of $\log_3 x$ is defined as $x > 0$, so required solutions are $x = 9, 27$.

Example 15: Solve for x : $\log_b(\log_b Ax) = 1$; $A > 0$

Solution: $\log_b(\log_b Ax) = 1$
 $\Rightarrow \log_b Ax = b$
 $\Rightarrow Ax = b^b$
 $\Rightarrow x = \frac{1}{A}(b^b)$

EXERCISE 2.4

1. Solve for x .

(a) $\log_3(2x - 5) = 2$

(b) $\log_7(3x) + \log_7 2 = \log_7 24$

(c) $\log_5(x + 3) - \log_5(x - 1) = 1$

(d) $\log_2(x^2 - 7) = 3$

2. Solve for x .

(a) $\log_2(x - 3) + \log_2(x + 1) = 5$

(b) $2\log_4 x = \log_4(5x - 4)$

(c) $\log_5(x + 2) + \log_5(x - 2) = 1$

(d) $\log_{10}(x - 2) + \log_{10}(x + 1) = 1$

3. Solve for x .

(a) $\log_x(3x+10) = 2$, where $x > 0$ and $x \neq 1$

(b) $(\log_3 x)^2 - 4\log_3 x + 3 = 0$

(c) $(\log_2 x)^2 + \log_2 x^3 = 10$

(d) $x^{\log_{10} x} = 1000x^2$

4. Solve for x .

(a) $\log_3(x^2 - 1) = \log_3(2x - 1)$

(b) $\log_x 5 - \log_x 2 = \log_x \sqrt{x}$

(c) $\log_2 x + \frac{1}{\log_x 2} = 4$

(d) $\log_3(3+x) + \log_3(8-x) - \log_3(9x-8) = 2 - \log_3 9$

(e) $\log_{10}[\log_2(\log_3 9)] = 5x$

5. If $x = \log \frac{1}{2} + \log \frac{2}{3} + \log \frac{3}{4} + \dots + \log \frac{99}{100}$, where all logs are to the base 10, then evaluate $(x+1)(x+2)(x+3) \dots (x+99)$.

Enrichment – Graph of logarithmic and Exponential functions

The graph of logarithmic function and exponential function are inverse of each other. Note that the graph of these functions are mirror images along the line $y = x$.

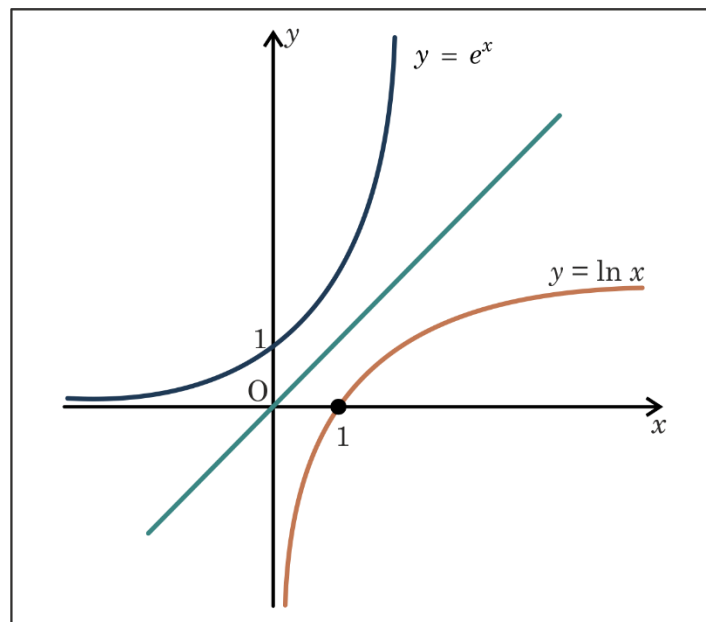

Summary

- **Logarithm** is the inverse operation of exponentiation.
- $\log_b a = x \Leftrightarrow b^x = a$, where $a > 0$ and $b > 0, b \neq 1$
- Logarithms are defined only for positive numbers.
- If the base of a logarithm is not given then we assume it to be 10 and such logarithms are called common logarithms.

- **Important Properties:**

For $b > 0, b \neq 1$ and $M > 0, N > 0$ we have:

- Product Rule: $\log_b(M \times N) = \log_b M + \log_b N$
- Quotient Rule: $\log_b\left(\frac{M}{N}\right) = \log_b M - \log_b N$
- Power Rule: $\log_b(M^k) = k \times \log_b M$
- Log of a number to the same base: $\log_b(b) = 1$
- Log of 1: $\log_b(1) = 0$
- The base changing property:

For any logarithmic bases b and a and any positive number n ,

$$\log_b n = \frac{\log_a n}{\log_a b}$$

- **Applications:** Logarithms are widely used in:
 - Earthquake measurement
 - Acidity (pH scale)
 - Sound intensity
 - Population growth
 - Sports science
-

SCIENCE

Subject Code – 086

Classes IX (2026-27)

Introduction

Science is the study of the natural and physical world around us through a systematic process of observing, questioning, forming hypotheses, testing hypotheses through experiment, analysing evidence, and continuously revising our knowledge. It develops essential skills like curiosity, creativity, evidence-based thinking, and sound decision-making that help us lead rational and fulfilling lives. Learning Science provides valid knowledge about the world, and builds scientific values and capacities. It draws knowledge from Biology, Chemistry, Physics, Earth Science, Mathematics, Computational Sciences, and sometimes Social Science and Vocational Education to offer an interdisciplinary understanding of the role of science.

Science Education helps students to develop an understanding of the natural and physical world through systematic inquiry. Learning Science also develops important capacities, such as observation, questioning, analysis, inference, etc. This helps individuals to meaningfully participate in society and the world of work with a scientific temper, critical and evidence-based thinking, asking relevant questions, analysing practices and norms, and acting for necessary change.

Science Education aims to achieve:

- Scientific understanding of the natural and physical world;
- Capacities for scientific inquiry;
- Understanding the evolution of scientific knowledge;
- Interdisciplinary understanding between Science and other curricular areas;
- Understanding of the relationship between Science, Technology, and Society;
- Scientific temper, and
- Creativity.

Together, the NEP 2020 and NCF-SE 2023 envision science classrooms that encourage curiosity, creativity, collaboration and connection with the real world, ultimately nurturing not just future scientists, but responsible, informed and critically thinking citizens.

Learning standards (Curricular Goals and Competencies) describe what students should know, understand, and be able to do in Science. In Grades 9 – 10, Science is taught using an integrated approach that combines Biology, Chemistry, Physics, and Earth Science. This helps students understand the connections between disciplines and relate Science to their observations and experiences. At this stage, scientific inquiry skills are developed alongside conceptual understanding, with content selected both for disciplinary relevance and real-life usefulness. Students must deepen their understanding of the world, explore scientific questions through discussion and experimentation, and communicate their learning in various ways. It is important to note that the Curricular Goals are interdependent and not separate.

Learning standards are organised into four levels: broad curricular aims define the overall objectives for Science Learning by the end of each schooling stage; more specific Curricular Goals guide the design of the science curriculum for each stage and topic; Competencies

represent measurable scientific skills and knowledge-based on these goals, assessed at the end of each stage; and detailed Learning Outcomes (LOs) are granular milestones of learning and usually progress in a sequence leading to the attainment of a competency. These LOs enable teachers to plan their content, pedagogy, and assessments towards achieving specific competencies.

Curricular Goals (CGs) and Competencies (Cs)

CG 1 – Explores the world of matter, its interactions, and properties at the atomic level

C 1.1 – Describes classification of elements in the Periodic Table, and explains how compounds (including carbon compounds) are formed based on the atomic structure (Bohr's model) and properties (valency).

C 1.2 – Investigates the nature and properties of chemical substances (distillation, crystallisation, chromatography, centrifugation, types and properties of mixtures, solutions, colloids, and suspensions)

C 1.3 – Describes and represents chemical interactions and changes using symbols and chemical equations (acid and base, metal and non-metal, reversible and irreversible)

CG 2 – Explores the physical world around them, and understands scientific principles and laws based on observations and analysis

C 2.1 – Applies Newton's laws to explain the effect of forces (change in state of motion — displacement and direction, velocity and acceleration, uniform circular motion, acceleration due to gravity) and analyses graphical and mathematical representations of motion in one dimension

C 2.2 – Explains the relationship between mass and weight using universal law of gravitation, and connect it to the laws of motion

C 2.3 – Manipulates the position of object and properties of lenses (focus, centre of curvature) to observe image characteristics and correspondence with a ray diagram, and extends this understanding to a combination of lenses (telescope, microscope)

C 2.4 – Manipulates and analyses different characteristics of the circuit (current, voltage, resistance) and mathematises their relationship (Ohm's law), and applies it to everyday usage (electricity bill, short circuit, safety measures)

C 2.5 – Defines work in scientific terms, and represents the relationship between potential and kinetic energy (conservation of energy) in mathematical expressions

C 2.6 – Demonstrates the principle of mechanical advantage by constructing simple machines (system of levers and pulleys)

C 2.7 – Describes the origin and properties of sound (wavelength, frequency, amplitude) and differences in what we hear as it propagates through different instruments

C 2.8 – *Explores interconnected systems and phenomena that support and affect life on Earth (hydrosphere, biosphere, atmosphere, geosphere, cryosphere and their interrelationships, earth processes, hazards, etc.)

*Additional Competency for Earth Science

CG 3 – Explores the structure and function of the living world at the cellular level

C 3.1 – Explains the role of cellular components (nucleus, mitochondria, endoplasmic reticulum, vacuoles, chloroplast, cell wall), including the semi-permeability of cell membrane in making cell the structural basis of living organisms and functional basis of life processes

C 3.2 – Analyses similarities and differences in the life processes involved in nutrition (photosynthesis in plants; absorption of nutrients in fungi; digestion in animals), transport (transport of water in plants; circulation in animals), exchange of materials (respiration and excretion), and reproduction

C 3.3 – Describes the mechanisms of heredity (in terms of DNA, genes, chromosomes) and variation (as changes in the sequence of DNA)

CG 4 – Explores interconnectedness between organisms and their environment

C 4.1 – Applies the knowledge of cellular diversity in organisms along with the ecological role organisms play (autotrophic or heterotrophic nutrition) to classify them into five kingdoms

C 4.2 – Illustrates different levels of organisations of living organisms (from molecules to organisms)

C 4.3 – Analyses different levels of biological organisation from organisms to ecosystems and biomes along with interactions that take place at each level

C 4.4 – Analyses patterns of inheritance of traits in terms of Mendel's laws and its consequences at a population level (using models and/or simulations)

C 4.5 – Analyses evidences of biological evolution demonstrating the consequences of the process of natural selection in terms of changes—in allele frequency in population, structure, and function of organisms

CG 5 – Draws linkages between scientific knowledge and knowledge across other curricular areas

C 5.1 – Explores how literature and arts have influenced Science

C 5.2 – Examines a case study related to the use of Science in human life from the perspective of Social Sciences and Ethics (for example, Marie Curie, Jenner, treatment of patients with mental illnesses, the story of the atomic bomb, green revolution and GMOs, conservation of biodiversity)

C 5.3 – Applies scientific principles to explain phenomena in other subjects (sound pitch, octave, and amplitude in music; use of muscles in dance form and sports)

CG 6 – Understands and appreciates the contribution of India through history, and the present time to the overall field of Science, including the disciplines that constitute it

C 6.1 – Knows and explains the significant contributions of India to all matters (concepts, explanations, methods) that are studied within the curriculum in an integrated manner

CG 7 – Develops awareness of the most current discoveries, ideas, and frontiers in all areas of scientific knowledge in order to appreciate that Science is ever evolving, and that there are still many unanswered questions

C 7.1 – States concepts that represent the most current understanding of the matter being studied, ranging from mere familiarity to conceptual understanding of the matter as appropriate to the developmental stage of the students

C 7.2 – States questions related to matters in the curriculum for which current scientific understanding is well-recognised

CG 8 – Explores the nature of Science by doing Science

C 8.1 – Develops accurate and appropriate models (including geometric, mathematical, graphical) to represent real-life events and phenomena using scientific principles, and use these models to manipulate variables and predict results

C 8.2 – Designs and implements a plan for scientific inquiry (formulates hypotheses, makes predictions, identifies variables, accurately uses scientific instruments, represents data— primary and secondary—in multiple modes, draws inferences based on data, and understanding of scientific concepts, theories, laws and principles, and communicates findings using scientific terminology)

COURSE OUTLINE

CLASS IX (2026-27)

Cell

No. of Periods: 12

| Key Concepts | | Learning Outcomes |
|---|-------|--|
| <ul style="list-style-type: none"> • Discovery of cell • Plant and animal cells • Prokaryotic and eukaryotic cells • Cell as a structural and functional unit of life; structure and function of key organelles (nucleus, mitochondria, chloroplast, endoplasmic reticulum, vacuoles, plasma membrane, cell wall) • Permeability of cell membranes • Cellular division and cancer • Recent advancement in cell biology | C-3.1 | <ul style="list-style-type: none"> • Differentiate between plant and animal cell, prokaryote and eukaryote • Describe the structural and functional features of cells • Explain the role of cells in the structure and functions of organisms • Explain activities inside the cell and its interactions with the environment • Demonstrate osmosis in cells • Prepare slides to observe cell structure |
| | C-3.2 | <ul style="list-style-type: none"> • Differentiate between diffusion and osmosis |
| | C-3.3 | <ul style="list-style-type: none"> • Explain the role of cell division mitosis and meiosis in creating similarities and variations |
| | C-4.2 | <ul style="list-style-type: none"> • Identify and describe the role of biomolecules in the structure and function of cell |
| | C-5.2 | <ul style="list-style-type: none"> • Cite case study related to the use of science in human life, for example, Leigh Syndrome and mitochondrial dysfunction |
| | C-5.3 | <ul style="list-style-type: none"> • Apply learning of a structure and function of muscles cells or joints in dance form and/or sports |
| | C-6.1 | <ul style="list-style-type: none"> • Discuss significant contributions of India, for example, Professor Arun Kumar Sharma for his work on chromosomes and methods for its studies |
| | C-7.1 | <ul style="list-style-type: none"> • Recognise that the cell is a structural unit of life and functional unit of life processes |
| | C-7.2 | <ul style="list-style-type: none"> • Pose questions, such as — Can we create artificial cell which behaves exactly like a natural living cell? |

| | | |
|--|-------|---|
| | C-8.1 | <ul style="list-style-type: none"> Exhibit creativity and design models using low cost or no-cost eco-friendly material to study structure and functions of cell and cell organelles |
| | C-8.2 | <ul style="list-style-type: none"> Carry out an experiment to understand the osmosis Analyze result and present finding using scientific terms |

Tissues

No. of Periods: 13

| Key Concepts | | Learning Outcomes |
|--|-------|--|
| <p>Tissues: Introduction and importance</p> <ul style="list-style-type: none"> Level of organisation in the living organisms Plant and animal tissues Types of plant tissues Meristematic tissues (types and function of each) Permanent tissues (types, structure and function of each) Animal tissues Overview (epithelial, connective, muscular and nervous tissues — types, structure and function of each) Elementary idea of musculoskeletal system Care of musculoskeletal system: injuries, postural care, nutrition and exercise | C-4.2 | <ul style="list-style-type: none"> Differentiate between plant and animal tissues; meristematic and permanent tissues; simple and complex tissues; parenchyma, collenchyma and sclerenchyma; xylem and phloem; striated smooth and cardiac muscles; Different types of joints Relate the structure of the different types of tissues with their functions Explain the role of various types of tissues in plants and animals Describe the level of organisation in a multicellular organism |
| | C-5.3 | <ul style="list-style-type: none"> Establish the correlation between different tissues for fitness, for example, role of muscles, cartilage and bones in facilitating movement |
| | C-6.1 | <ul style="list-style-type: none"> Explain the importance of yoga exercises for physical agility and in maintaining the correct posture |
| | C-6.1 | <ul style="list-style-type: none"> Discuss significant contributions of India, for example, Professor Sipra Guha Mukherjee and Professor S.C. Maheshwari for their significant contribution in the plant cell and tissue culture research in India |
| | C-7.1 | <ul style="list-style-type: none"> Discuss the techniques and medical recommendations in recovery from muscular injuries |

| | | |
|--|-------|---|
| | C-8.2 | <ul style="list-style-type: none"> • Carry out an experiment to understand the growth in plant due to apical meristem • Represent data in multiple modes, including appropriate figures, tables, graphs, or digital formats, interpret and draw inferences from the data • Analyse results and present findings using scientific terms • Communicate findings and conclusions effectively, such as those from experiments, activities, or projects, both orally and in written form |
|--|-------|---|

Reproduction

No. of Periods: 13

| Key Concepts | | Learning Outcomes |
|--|-------|---|
| <ul style="list-style-type: none"> • Introduction to different forms of reproduction — sexual and asexual • Types of asexual reproduction with examples • Sexual reproduction in flowering plants (flower and its parts, pollination, fertilisation, seed dispersal) • Sexual reproduction in humans: male and female reproductive systems (structure and function, formation of gametes, sperm and egg, fertilisation, pregnancy and development of embryo, menstrual cycle) • Reproductive health and hygiene • Introduction to birth control methods and importance | C-2.8 | <ul style="list-style-type: none"> • Analyse the interactions between members of different groups of organisms, such as plants and pollinators |
| | C-3.2 | <ul style="list-style-type: none"> • Compare asexual and sexual reproduction • Describe male and female reproductive organs in plants and animals • Differentiate between ovule and seed; ovary and fruit • Explain pollination and fertilisation |
| | C-3.3 | <ul style="list-style-type: none"> • Explain how variations are introduced by sexual reproduction |
| | C-4.3 | <ul style="list-style-type: none"> • Identify and explain the role of biotic and abiotic agents in seed dispersal and pollination |
| | C-5.1 | <ul style="list-style-type: none"> • Illustrate the structure of male and female reproductive units or systems in plants and animals |
| | C-5.2 | <ul style="list-style-type: none"> • Recognise the significance of contraceptive devices for population control and health including reproductive health |
| | C-6.1 | <ul style="list-style-type: none"> • Describe the contribution of India to the understanding of human anatomy |
| | C-6.1 | <ul style="list-style-type: none"> • Discuss significant contributions of India, for example, Professor Panchanan Maheshwari for |

| | | |
|--|-------|--|
| | | laying the foundation of plant cell and tissue culture research in India |
| | C-7.1 | <ul style="list-style-type: none"> Recognise the importance of improvements in medical field for assisted reproductive technologies |
| | C-7.2 | <ul style="list-style-type: none"> Pose questions, such as — How do heavy metals harm reproductive organs? Can extreme heat affect fertility? |

Diversity

No. of Periods: 12

| Key Concepts | | Learning Outcomes |
|--|--------|--|
| <ul style="list-style-type: none"> Importance of classification Five kingdoms and their key features with examples Major division of animals and plants Binomial nomenclature Acellular entities: viruses | C-4.1 | <ul style="list-style-type: none"> Distinguish organisms based on certain characteristics, such as number of cells present, cellular organisation and mode of nutrition Classify various organisms in groups, such as five kingdoms, on the basis of their cellular organisation and ecological role Describe the significance and rules of binomial nomenclature Apply binomial nomenclature on some common organisms in their surroundings |
| | C-2.8 | <ul style="list-style-type: none"> Analyse the interactions between members of different groups of organisms, such as lichens Discuss ecological role of diverse organisms |
| | C--7.1 | <ul style="list-style-type: none"> Recognise three domains of classification of organisms on molecular basis |

Exploring Mixtures and their Separation

No. of Periods: 12

| Key Concepts | | Learning Outcomes |
|--|-------|--|
| <ul style="list-style-type: none"> Homogeneous and heterogeneous mixtures; Solutions, suspensions, colloids and their properties Various ways to express concentration of solutions (mass by mass percentage of a solution, | C-1.2 | <ul style="list-style-type: none"> Differentiate between homogeneous and heterogeneous mixtures on the basis of their properties Demonstrate separation techniques, such as crystallisation, distillation, paper chromatography, sublimation, centrifugation and coagulation Classify mixtures as solutions, suspensions, or colloids based on their properties Explain the scientific principles behind different |

| | | |
|---|-------|--|
| <p>mass by volume percentage of a solution, volume by volume percentage of a solution)</p> <ul style="list-style-type: none"> Separation techniques based on the physical properties of components, including crystallisation, distillation, paper chromatography, sublimation, centrifugation and coagulation | | <p>separation techniques</p> <ul style="list-style-type: none"> Apply the knowledge of homogeneous and heterogeneous mixtures in daily life Define and calculate the concentration of solutions using mass by mass percentage, mass by volume percentage, volume by volume percentage Analyse graphs of solubility and explain how the solubility of substances changes with temperature Use scientific conventions and standard units to express concentrations Handle common laboratory chemicals and apparatus safely Relate separation techniques with practices observed in the local environment |
| | C-5.1 | <ul style="list-style-type: none"> Draw labelled diagrams or flow charts of separation techniques |
| | C-5.2 | <ul style="list-style-type: none"> Display awareness about the societal impact of chemistry in making life healthier, cleaner and sustainable |
| | C-5.3 | <ul style="list-style-type: none"> Correlate the phenomenon used in centrifugation to the spinning dance |
| | C-6.1 | <ul style="list-style-type: none"> Describe the cultural practices, like traditional methods of distillation Display awareness about the contributions of Indian scientists, such as Dilip Mahalanabis |
| | C-7.1 | <ul style="list-style-type: none"> Demonstrate the use of small-scale or micro-scale experiments, such as crystallisation of copper sulfate, as an alternative to traditional methods |
| | C-7.2 | <ul style="list-style-type: none"> Poses question, such as — Can we create artificial blood that works just as real blood for all patients? |
| | C-8.1 | <ul style="list-style-type: none"> Exhibit creativity and work collaboratively in groups to create models of apparatus used for separating mixtures, such as a paperfuge and a distillation unit, using eco-friendly materials |
| | C-8.2 | <ul style="list-style-type: none"> Formulate hypotheses about scientific phenomena based on prior knowledge and understanding of scientific concepts, and predict the results of an experiment or investigation based on their hypotheses |

| | | |
|--|--|--|
| | | <ul style="list-style-type: none"> • Accurately use scientific instruments, apparatus and chemicals to collect data • Analyse results and findings using scientific terms • Represent findings in multiple modes, including appropriate figures, tables, graphs, or digital formats, and interpret and draw inferences from the findings • Communicate findings and conclusions effectively, such as those from experiments, activities or projects, both orally and in written form |
|--|--|--|

Structure of an Atom

No. of Periods: 14

| Key Concepts | | Learning Outcomes |
|---|-------|---|
| <ul style="list-style-type: none"> • Atoms are the basic units of elements • Atoms consist of subatomic particles • Atomic Models (Thomson's Model, Rutherford's Model, and Bohr's Model) • Distributions of electrons in elements (up to 18 elements) • Symbols • Valency as the combining capacity • Atomic number • Mass number • Isotopes • Isobars | C-1.1 | <ul style="list-style-type: none"> • Differentiate between subatomic particles (electrons, protons, and neutrons) based on their charge, and position in the atom • Illustrate how electrons are distributed in different energy levels, such as K, L, M, N ... or by numbers $n = 1, 2, 3, 4 \dots$ • Explain valence electrons, valency, atomic number, atomic mass, isotopes, and isobars • Calculate the number of electrons, protons, and neutrons of an element using its atomic and mass numbers • Interpret data, such as atomic mass, maximum number of electrons in a shell, and valency to classify elements accurately • Use scientific conventions as per international standards, such as notations for electron, proton, neutron, unified atomic mass unit (u), and distribution of electrons in various shells, such as K, L, M, N ... |
| | C-1.3 | <ul style="list-style-type: none"> • Recognise and accurately apply the chemical symbols for the first eighteen elements according to IUPAC |
| | C-5.1 | <ul style="list-style-type: none"> • Draw labelled diagrams of various atomic models, such as Thomson's model, Rutherford's model and Bohr's model • Create and present a role play, stage play, or story of 'Journey Inside the Atom' to display awareness about the contributions of key scientists in the |

| | | |
|--|-------|--|
| | | discovery and development of atomic structure |
| | C-5.2 | <ul style="list-style-type: none"> • Display awareness about the role of Indian scientists and their contributions to atomic science for peaceful purposes and explore how their works influenced India's scientific development |
| | C-5.3 | <ul style="list-style-type: none"> • Display awareness about the societal impact of science in making life healthier, like the use of various isotopes in medicines to treat different diseases, and atomic energy in power generation • Design and develop games that utilise atomic number, mass number, and subatomic particle clues to accurately predict and identify elements |
| | C-6.1 | <ul style="list-style-type: none"> • Display awareness about the contributions of the ancient Indian philosopher, Acharya Kanad's idea of indivisible particles (Parmanu) |
| | C-7.1 | <ul style="list-style-type: none"> • Describe the use of the atomic mass unit (u) to measure the mass of atoms as per IUPAC recommendations • Describe scientific discoveries that explain how the structure of the atom has evolved over time through various atomic models proposed by different scientists |
| | C-7.2 | <ul style="list-style-type: none"> • Pose question, such as—is it possible to completely understand everything that happens inside an atom? |
| | C-8.1 | <ul style="list-style-type: none"> • Exhibit creativity and work collaboratively in groups to design different models of atoms |
| | C-8.2 | <ul style="list-style-type: none"> • Formulate hypotheses about scientific phenomena by applying prior knowledge and understanding of scientific concepts, and predict the results of data based on the hypotheses • Analyse results and present findings using scientific terms • Correlate the results and conclusions of different models of atomic structure • Represent data in multiple modes, including appropriate figures, tables, graphs or digital formats, and interpret and draw inferences from the data |

| | | |
|--|--|---|
| | | <ul style="list-style-type: none"> Communicate findings and conclusions effectively, such as those from experiments, activities or projects, both orally and in written form |
|--|--|---|

Atoms and Molecules

No. of Periods: 14

| Key Concepts | | Learning Outcomes |
|--|-------|---|
| <ul style="list-style-type: none"> Law of conservation of mass Law of constant proportion Dalton's Atomic theory Molecules of elements, Molecules of covalent compounds and their properties Ions, Ionic compounds and their properties Writing chemical formulae Molecular mass Formula unit mass | C-1.1 | <ul style="list-style-type: none"> Differentiate between chemical species based on their properties or characteristics, such as atoms and molecules, elements and compounds, ionic and covalent compounds, cations and anions, formula unit mass and molecular mass Plan and demonstrate activities to observe and verify the law of conservation of mass Explain the Dalton's atomic theory, the law of conservation of mass, the law of constant proportions, and formation of ionic and covalent compounds Calculate the charge on an ion, valency from the atomic number, the molecular and formula unit mass Use scientific conventions, symbols, and valency to write the chemical formulae of simple compounds Display awareness about the scientific discoveries, such as the contributions of Antoine Lavoisier, Joseph Proust, and John Dalton Handle common laboratory chemicals and apparatus safely |
| | C-5.1 | <ul style="list-style-type: none"> Draw diagrams of electron dot structures of atoms and molecules |
| | C-5.2 | <ul style="list-style-type: none"> Describe how atoms and molecules can lead to beneficial applications, such as medicine, energy and peaceful use of atomic science Relate atomic bonding to social bonding |
| | C-5.3 | <ul style="list-style-type: none"> Design educational games to write chemical formulae using symbols |
| | C-6.1 | <ul style="list-style-type: none"> Display awareness about the contributions of Indian scientists in promoting the peaceful use of atomic energy and the traditional use of the red pigment 'cinnabar' obtained from rocks |

| | | |
|--|-------|--|
| | C-7.1 | <ul style="list-style-type: none"> Describe the basic concepts that matter are made of particles; elements combine in fixed ratios to form compounds; the law of conservation of mass; and different types of bonding (ionic and covalent) |
| | C-7.2 | <ul style="list-style-type: none"> Pose question, such as — Are there any chemical changes that do not obey the law of conservation of mass? |
| | C-8.1 | <ul style="list-style-type: none"> Exhibit creativity and work collaboratively in groups to construct simple models of compounds |
| | C-8.2 | <ul style="list-style-type: none"> Formulate hypotheses about scientific phenomena by applying prior knowledge and understanding of scientific concepts and laws, and predict the results of data based on the hypotheses Accurately use scientific instruments, apparatus and chemicals to collect data Analyse results and findings using scientific terms Represent data in multiple modes, including appropriate figures, tables, graphs or digital formats Communicate findings and conclusions effectively, such as those from experiments, activities or projects, both orally and in written form |

Earth as a System: Energy, Matter & Life

No. of Periods: 12

| Key Concepts | | Learning Outcomes |
|---|-------|---|
| <ul style="list-style-type: none"> Earth as interconnected system Nature of solar energy: solar radiation, electromagnetic spectrum, and speed of light Solar energy interaction with the Earth's Surface and differential heating of the Earth (the role of the atmosphere and the Earth's surface) Differential warming of the Earth causes winds | C-2.8 | <ul style="list-style-type: none"> Explain the interconnectedness between different spheres of the Earth (biosphere, geosphere, hydrosphere, cryosphere and atmosphere) Explain the nature of solar radiation • Explain that solar radiation is an electromagnetic waves having different Frequencies Explain how heat from the Sun warms the Earth's surface differently based on the shape, latitude and tilt of the Earth Explain the interaction of solar radiation with the Earth's surface and relate the differential heating of the Earth's surface with the atmospheric phenomena, such as air movement, evaporation, etc., and describe phenomena like mountain, valley, sea and land breezes |

| | | |
|---|-------|--|
| <ul style="list-style-type: none"> • Biogeochemical cycles (water cycle, carbon cycle, nitrogen cycle, oxygen cycle) • Human impact on Earth's system | | <ul style="list-style-type: none"> • Describe how the latitude and tilt of the Earth, and absorption and reflection of solar radiation by different surfaces cause differential heating of the Earth's surface • Identify various components of the Earth that interact with solar energy • Explain the role of the atmosphere in influencing weather and climate on the Earth • Identify the reflectivity of different materials through reliable scientific sources, such as the internet and books • Describe how elements like carbon, nitrogen, oxygen and water are recycled between biotic and abiotic environments • Explain biogeochemical cycles, and the roles of biogeochemical cycles in circulating matter and energy continuously between the non-living environment (abiotic) and living (biotic) organisms, making nutrients available, and maintaining environmental balance |
| | C-6.1 | <ul style="list-style-type: none"> • Reflect the changing nature of Earth's environment through our traditional knowledge |
| | C-7.2 | <ul style="list-style-type: none"> • Pose questions, such as — What will happen if there is no differential heating of the Earth? |
| | C-8.1 | <ul style="list-style-type: none"> • Draw flow charts, concept maps for biogeochemical cycles, differential heating of the Earth's surface and Electromagnetic spectrum |
| | C-8.2 | <ul style="list-style-type: none"> • Formulate hypotheses about scientific phenomena based on prior knowledge and understanding of differential heating of the Earth and biogeochemical cycle • Predict the results of an experiment or investigation based on their hypotheses • Communicate findings and conclusions effectively, such as those from experiments, activities or projects, both orally and in written form |

Motion**No. of Periods: 13**

| Key Concepts | | Learning Outcomes |
|--|-------|--|
| <ul style="list-style-type: none"> • Motion — displacement, velocity, acceleration • Graphical representation of motion for an object moving in a straight line in one direction (with constant velocity, and constant acceleration) • Kinematic equations for motion in a straight line with constant acceleration (by graphical method) • Elementary idea of uniform circular motion | C-2.1 | <ul style="list-style-type: none"> • Differentiate between distance travelled and displacement, and speed and velocity for objects moving in a straight line • Define displacement, velocity, acceleration, and uniform circular motion • Express displacement, velocity, acceleration in appropriate SI units • Plot and interpret position-time graphs and velocity-time graphs to describe the motion of an object moving in a straight line in one direction (with constant velocity and constant acceleration) • Calculate average velocity from position-time graph, displacement and average acceleration from velocity-time graph • Derive kinematic equations for motion in a straight line with constant acceleration by graphical method • Calculate values of unknown physical quantities from the given physical quantities, using kinematic equations • Derive the expression of speed for uniform circular motion |
| | C-8.1 | <ul style="list-style-type: none"> • Analyse real-life events and phenomena, and identify the key factors that influence their Behaviour. |
| | C-8.2 | <ul style="list-style-type: none"> • Formulate hypotheses about scientific phenomena based on prior knowledge and understanding of scientific concepts, theories, laws, and principles • Predict about the outcome of an experiment or investigation based on their hypotheses • Identify the variables that are relevant to a scientific investigation and determine how to control or manipulate them • Accurately use scientific instruments and equipment to collect data • Represent data in multiple modes, including tables, graphs and visual representations, and interpret and draw inferences from the data • Communicate their findings using scientific terminology and effectively communicate their conclusions to others |

Force and Laws of Motion**No. of Periods: 13**

| Key Concepts | | Learning Outcomes |
|---|-------|--|
| <ul style="list-style-type: none">• Force; balanced and unbalanced forces• Force of friction• Newton's first law of motion• Newton's second law of motion• Newton's third law of motion | C-2.1 | <ul style="list-style-type: none">• Explain that force has magnitude as well as direction• Identify situations in which balanced and unbalanced forces are acting on an object• Explain the role of friction on the motion of objects• Recognise that for an object moving with constant velocity, the net force is zero, whereas a change in velocity (acceleration) is caused by a force• State and explain Newton's first law of motion• State and explain Newton's second law in terms of mass and acceleration• Calculate force using mathematical expression of Newton's second law of motion• Define SI unit of force• State and explain Newton's third law of motion• Apply Newton's laws of motion to explain everyday life events |
| | C-8.1 | <ul style="list-style-type: none">• Analyse real-life events and phenomena, and identify the key factors that influence their behaviour• Develop a model to represent real-life event• Use models to manipulate variables and predict results |
| | C-8.2 | <ul style="list-style-type: none">• Formulate hypotheses about scientific phenomena based on prior knowledge and understanding of scientific concepts, theories, laws, and principles• Predict about the outcome of an experiment or investigation based on their hypotheses• Identify the variables that are relevant to a scientific investigation and determine how to control or manipulate them• Accurately use scientific instruments and equipment to collect data• Represent data in multiple modes, including tables, graphs and visual representations, and interpret and draw inferences from the data• Communicate their findings using scientific terminology and effectively communicate their conclusions to others |

Work, Energy and Simple Machines

No. of Periods: 13

| Key Concepts | | Learning Outcomes |
|---|-------|---|
| <ul style="list-style-type: none"> • Concept of work; work done by a constant force • Work-Energy theorem • Mechanical energy, kinetic and potential energy, and conversion between potential energy and kinetic energy • Conservation of energy • Power • Simple machines and their mechanical advantage (pulley, inclined plane, lever) | C-2.5 | <ul style="list-style-type: none"> • Define work done by a constant force and its SI unit • Calculate work done by a force using mathematical expression • State work-energy theorem • Explain the concept of energy and state its SI unit • Name forms of energy and identify their interconversion in surroundings (elementary idea) • Define kinetic energy of a moving object and derive its mathematical expression • Define potential energy for an object raised to a height and derive its mathematical expression • Calculate kinetic and potential energy using mathematical expressions • Explain conversion between potential energy and kinetic energy (for the case of an object under free fall) • State the law of conservation of energy • Define power and its unit • Calculate power using its mathematical expression |
| | C-2.6 | <ul style="list-style-type: none"> • Identify different simple machines (pulley, inclined plane and lever) • Define mechanical advantage and calculate its value for simple machine • Demonstrate and explain mechanical advantage of simple machines their conclusions to others |
| | C-8.1 | <ul style="list-style-type: none"> • Analyse real-life events and phenomena, and identify the key factors that influence their behaviour • Develop model to represent real-life event • Use models to manipulate variables and predict results |
| | C-8.2 | <ul style="list-style-type: none"> • Formulate hypotheses about scientific phenomena based on prior knowledge and understanding of scientific concepts, theories, laws, and principles • Predict about the outcome of an experiment or investigation based on their hypotheses • Identify the variables that are relevant to a scientific |

| | | |
|--|--|---|
| | | <p>investigation and determine how to control or manipulate them</p> <ul style="list-style-type: none"> • Accurately use scientific instruments and equipment to collect data • Represent data in multiple modes, including tables, graphs and visual representations, and interpret and draw inferences from the data • Communicate their findings using scientific terminology and effectively communicate their conclusions to others |
|--|--|---|

Sound

No. of Periods: 11

| Key Concepts | | Learning Outcomes |
|---|-------|---|
| <ul style="list-style-type: none"> • Production of sound • Propagation of sound (as a longitudinal wave through a medium) • Graphical representation of sound wave • Characteristics of sound wave (wavelength, frequency, time period, amplitude, intensity, speed) • Human perception of sound (pitch, loudness) • Propagation of sound in different media (solid, liquid) • Reflection of sound (echo, reverberation), echolocation | C-2.7 | <ul style="list-style-type: none"> • Demonstrate the production of sound in multiple ways (through vibration of strings, membranes, air columns) using materials in surroundings • Explain that sound is produced by vibrations • Demonstrate that sound can travel through different mediums (air, solid and liquid) • Describe that sound needs a medium for propagation • Explain that sound travels as a longitudinal wave • Describe the characteristics of sound waves the (wavelength, frequency, time period, amplitude, intensity and speed) • Analyse graphs representing sound • Write relationship between time period and frequency of sound wave • Derive mathematical expression for speed of sound • Calculate speed of sound using its mathematical expression • Explain human perception of sound in terms of audible range, loudness and pitch of sound • Describe reflection of sound, and apply it to echo and reverberations in surroundings • Explain the use of sound waves for echolocation |
| | C-5.3 | <ul style="list-style-type: none"> • Describe music in terms of characteristics of sound waves, such as loudness and pitch |
| | C-6.1 | <ul style="list-style-type: none"> • Name historical buildings designed for echoes, such as whispering gallery of Gol Gumbaz |

| | | |
|--|-------|--|
| | | <ul style="list-style-type: none"> • Display awareness about Sir C.V. Raman |
| | C-8.1 | <ul style="list-style-type: none"> • Analyse real-life events and phenomena, and identify the key factors that influence their behaviour • Develop model to represent real-life event • Use models to manipulate variables and predict results |
| | C-8.2 | <ul style="list-style-type: none"> • Formulate hypotheses about scientific phenomena based on prior knowledge and understanding of scientific concepts, theories, laws, and principles • Predict about the outcome of an experiment or investigation based on their hypotheses • Identify the variables that are relevant to a scientific investigation and determine how to control or manipulate them • Accurately use scientific instruments and equipment to collect data • Represent data in multiple modes, including tables, graphs and visual representations, and interpret and draw inferences from the data • Communicate their findings using scientific terminology and effectively communicate their conclusions to others |

Practical will be announced shortly.

| Assessment Structure | Marks |
|---|--------------|
| Annual Examination (03 hrs.) | 80 Marks |
| Internal Assessment <ul style="list-style-type: none"> • Periodic Assessment - 05 marks + 05 marks • Subject Enrichment (Practical Work) - 05 marks • Portfolio - 05 marks | 20 Marks |
| Total | 100 Marks |

PRESCRIBED BOOKS:

- Science-Textbook for class IX-NCERT Publication
- Assessment of Practical Skills in Science-Class IX - CBSE Publication
- Laboratory Manual-Science-Class IX, NCERT Publication
- Exemplar Problems Class IX – NCERT Publication

Science at Advanced Level (Optional)

Grade 9

2026-27

**Academic Unit,
Central Board of Secondary Education**

Integrated Office Complex, Sector-23, Phase - 1, Dwarka,
New Delhi - 110077



Table of Contents

| S. No. | Chapters | Pages |
|--------|--|-------|
| 1. | Measurement – Foundation of Science | 4-8 |
| 2. | Understanding Motion through Experience | 9-14 |
| 3. | Newton's Laws of Motion | 15-24 |
| 4. | The Geometry of Power – Advanced Simple Machines | 25-29 |
| 5. | Work and Energy | 30-33 |
| 6. | Structure of Atom | 34-41 |
| 7. | Chemical Bonding | 42-48 |
| 8. | Mixtures and their Separation | 49-53 |
| 9. | Microscope and Microscopy | 54-69 |
| 10. | Engineering Life: Miracles in Biotechnology | 69-86 |

Content Development Committee

Mr. Aishwary Meet, Physics Expert, Gaur International School, Noida

Ms. Alka Gupta, TGT Science, Mayoor School, Sector-126, Noida

Dr. Amit Sehgal, Professor, Hansraj College, University of Delhi

Dr. Anita Verma, Retired Professor, Kirori Mal College, University of Delhi

Ms. Cenkush Sharma, TGT, Vandana International School, Dwarka, Delhi

Ms. Geetanjali Padhy, Biology Educator, Suncity School, Sector-54, Gurugram

Dr. Girish Choudahry, Retd. Associate Professor, Lady Irwin College, University of Delhi

Professor K.K Arora, Professor, Zakir Husain College, University of Delhi

Ms. Mridula Arora, Head of School, Navayug School, Sarojini Nagar, New Delhi

Ms. Pamila Marwaha, PGT Chemistry, Navayug School, Sarojini Nagar, New Delhi

Dr. Renu Parashar, Professor, Hansraj College, University of Delhi

Dr. Sanjeev, Professor, IGNOU

Ms. Shivani Kaplish, TGT Science, Mayoor School, Sector-126, Noida

Ms. Varsha Krishnan, TGT, Bal Bharati Public School, Rohini, Delhi

Measurement- The Foundation of Science

1.1 Introduction: What is Measurement?

Measurement is the process of comparing an unknown quantity with a known standard quantity of the same kind. Physics is based on measurement. Whether we measure the length of a classroom, the mass of a bag, or the time taken by a runner, accurate measurement is essential

Examples

- A tailor measures cloth in meters.
- A doctor measures body temperature in degree Celsius.
- A shopkeeper measures rice in kilograms.

Without proper units, these measurements would have no meaning.

Activity 1.1 Measuring the area of the classroom floor

Materials: Take three sticks of length $l_1:l_2:l_3 = 1:2:3$

Procedure:

1. Divide students in 3 groups and hand over one stick to each group.
2. Each group will measure the length and width of the classroom taking stick as one unit.

| | Stick 1 | Stick 2 | Stick 3 |
|-----------------|--------------------------|--------------------------|--------------------------|
| Length of wall | units* | units | units |
| Breadth of wall | units | units | units |
| Area of floor | units ² | units ² | units ² |

**the unit refers to length of the stick used for measurement*

3. Compare the length, breadth and area measured by different groups and try to generate conclusions between unit chosen and numerical values obtained by all the three groups.

This activity demonstrates that the numerical value of a quantity is inversely proportional to the size of the unit used. Thus, when a larger unit (longer stick) is used to measure the classroom floor, the numerical value obtained is smaller, and

when a smaller unit is used, the numerical value is larger.

In measurement, the physical quantity remains constant even when the unit changes.

Hence,

$$Q = n_1 u_1 = n_2 u_2$$

Therefore,

$$n_2 = n_1 (u_1 / u_2)$$

Activity 1.2: Let's play an estimation game

Procedure:

1. Estimate the length of the blackboard without measuring.
2. Then measure its length using a meter scale.
3. Compare the estimated and measured values. Now, calculate the inaccuracy (error) in the measurement.

1.2 Different Systems of Units

In earlier times, different regions/places used their own units of measurement, which often led to confusion and errors.

(a) CGS System

- Length: centimeter (cm)
- Mass: gram (g)
- Time: second (s)

It is mainly used in laboratory and scientific calculations.

(b) FPS System

- Length: foot (ft)
- Mass: pound (lb)
- Time: second (s)

Commonly used in the United States.

(c) MKS System

- Length: meter (m)
- Mass: kilogram (kg)
- Time: second (s)

This system later developed into the SI (**International System of Units or *Système International d'Unités***) system.

Example

- The height of a person is largely measured in centimeters in India, while in some countries it is measured in feet and inches.

1.3. Need for a Common System of Units

Different systems of units caused difficulties in communication, trade, and scientific research.

Problems Without a Common System

- Confusion in international trade
- Errors in scientific calculations
- Difficulty in sharing scientific data

Example

If a scientist in India measures length in meters and another in the USA measures in feet, comparison becomes difficult unless a common unit is used.

Hence, a universal system of units was required.

Activity 1.3: Let us Compare

Materials: Ruler marked in cm and inches

Procedure:

1. Measure the length of a book using both cm and inches.
2. Compare the values and find the relation between them.

1.4. International System of Units (SI)

The International System of Units (SI) is the modern and universally accepted system of measurement.

SI Base Units

| Physical Quantity | SI Unit | Symbol |
|-------------------|----------|--------|
| Length | Meter | m |
| Mass | Kilogram | kg |
| Time | Second | s |
| Temperature | Kelvin | K |
| Electric Current | Ampere | A |

| | | |
|---------------------|---------|-----|
| Luminous Intensity | Candela | Cd |
| Amount of substance | Mole | mol |

Advantages of SI Units

- Internationally accepted
- Easy to use and understand
- Based on the decimal system

Examples

- Speed of vehicles is measured in m/s or km/h
- Medicines are measured in milligrams (mg)

1.5 Conversion of Units between different Systems

Sometimes, we need to convert a measurement from one unit to another to ensure comprehension across different systems.

During unit conversion, the numerical value and the unit may change, but the magnitude of the physical quantity remains the same.

Basic Conversions

- **1 km = 1000 m**
- **1 m = 100 cm**
- **1 kg = 1000 g**
- **1 hour = 3600 s**

Examples

Q. Convert 9 km/hr into m/s.

$$\text{Answer: } 9 \text{ km/hr} = \frac{9 \times 1000 \text{ m}}{3600 \text{ s}} = \frac{5}{2} \text{ m/s}$$

Q. Convert 1 N into gcm/s².

$$\text{Answer: } 1 \text{ kg m/s}^2 = 1000\text{g} \times 100 \text{ cm/s}^2 = 10^5 \text{ gcm/s}^2 = 10^5 \text{ dyne.}$$

Quick Check

1. Name any two systems of units.
2. Why is SI system preferred over other systems?
3. Convert 250 N into gcm/s².
4. Convert 1000 kg/L into kg/m³.

Check Your Understanding

1. Which of the following is not an SI unit?
 - a) Meter
 - b) Kilogram
 - c) Second
 - d) foot
2. The SI unit of mass is:
 - a) Gram
 - b) Kilogram
 - c) Pound
 - d) tonne
3. Name the system of units used internationally.
4. Why is a common system of units necessary?
5. Why is measurement necessary in physics?
6. Why was there a need for a common system of units?
7. Explain the relation: Magnitude = Numerical value \times Unit
8. Why does the same classroom floor give different numerical values when measured with sticks of different lengths?

Answer questions 9 to 11 that are based on Activity 1.1 (Measuring Classroom Floor)

Suppose:

| Stick Length | Length of Wall | Breadth of Wall |
|--------------|----------------|-----------------|
| 1 unit | 30 units | 20 units |
| 2 units | 15 units | 10 units |
| 3 units | 10 units | 6.6 units |

9. Why are numerical values different?
10. Is the actual size of the classroom different? Why or Why not?
11. What conclusion can you draw about units and measurement from this activity?
12. Fill in the blanks
 - a. Measurement is the process of comparing an unknown quantity with a _____ quantity.
 - b. The SI unit of mass is _____.

- c. In CGS system, the unit of length is _____.
- d. 1 km = _____ m.
- e. The modern internationally accepted system of units is called _____.

13. Match the following:

| Column A | Column B |
|----------|-----------------------|
| CGS | Kelvin |
| FPS | Pound |
| SI | International system |
| MKS | Meter-Kilogram-Second |

- 14. What problems might occur if every country used its own system of units for measurement?
- 15. A scientist measures length in feet and another in meters. What difficulties may it lead to?
- 16. If 1 meter was defined differently in different countries, what would happen to international trade?
- 17. A shopkeeper sells rice using kilograms. A foreign customer asks for rice in pounds.
 - a. Why is unit conversion necessary here?
 - b. If 1 kg = 2.2 pounds, how many pounds are there in 5 kg?

Understanding Motion Through Experience

Reflect on the following:

- Why do we feel pushed backward when a bus suddenly starts moving?
- Can an object be at rest for one observer but moving for another?
- How do athletes decide the best angle to throw a ball so that it travels the maximum distance?
- Can we measure motion using simple tools available in the classroom?

Discuss your ideas with classmates before beginning the activities.

2.1 What is Motion?

An object is said to be in motion if its position changes with time with respect to a reference point. Motion can be slow or fast, straight or curved, uniform or non-uniform. Understanding motion becomes easier when we observe it directly and measure it ourselves.

Activity 2.1: Let's observe

Materials: Notebook, stopwatch (mobile timer), measuring tape

Steps:

1. Mark two points 5 meters apart in the classroom corridor or playground.
2. Ask one student to walk normally from one point to another while another student measures the time taken using a stopwatch.
3. Repeat the experiment with the student running.
4. Record the distance and time in a table.

Observation: - Compare the time taken for walking and running. - Which motion is faster? How can you calculate speed?

Can motion be described using measurable quantities such as distance and time?

2.2 Frame of Reference

A frame of reference that is at rest or moving with constant velocity is called an inertial frame. Newton's laws hold without modification in such frames. A frame that is accelerating is called a non-inertial frame, and we will see in later sections that special corrections (pseudo forces) become necessary in such frames.

To describe the state of motion of an object, we must specify a reference point. Without it, we cannot say whether an object is moving or at rest.

Activity 2.2: Motion is Relative

Materials: Two students as props

Steps:

1. Let one student stand still while another walks past him.
2. Ask each student to describe the motion of the other student.
3. Now let both students walk in the same direction with the same speed and describe the motion again.

Discussion: - When both students walk together at the same speed, they appear at rest relative to each other but moving relative to the classroom.

2.3. Scalars and Vectors

Physical quantities are of two types: -

Scalars: Quantities having magnitude only (distance, time, mass, speed and work)

Vectors: Quantities having both magnitude and direction (displacement, velocity, force).

Activity 2.3: Direction Matters

Materials: Chalk, measuring tape

Steps:

1. Draw a straight 5-metre line on the ground and mark the starting point as A and the end as B.
2. Walk from A to B and note the distance covered.
3. Next walk from A to B and then back to A.
4. Compare the distance travelled and displacement.

Observation: - Distance changes but displacement becomes zero when returning to the starting point.

2.4 Vector Addition (Graphical Method)

Vectors are physical quantities that have both magnitude and direction, such as displacement, velocity, and force. When two or more vectors act together, we combine them to find a single vector called the **resultant**. This process is known as **vector addition**. Vectors can be added graphically using methods like the **triangle method** or the **parallelogram method**.

Activity 2.4: Graphical Addition of Displacements

Materials: Graph paper, ruler, pencil

Steps:

1. On graph paper, draw a vector representing 4 units towards the east.
2. From the head (end) of this vector, draw another vector representing 3 units towards the north.
3. Now join the tail (starting point) of the first vector to the head of the second vector.

Observation:

The line joining the starting point to the final point represents the **resultant displacement**.

This is how two vectors can be combined graphically to find a resultant vector, and how both magnitude and direction are important in describing motion.

Practice Question:

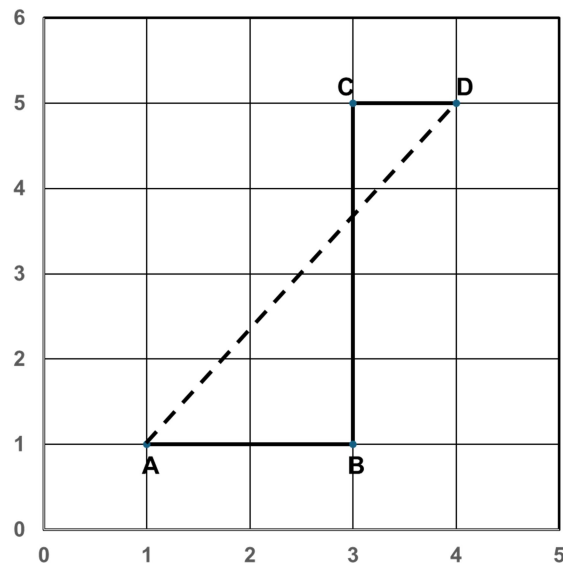

Points A at (1,1), B at (3,1), C at (3,5) and D at (4,5) (All the values mentioned in the graph are in km) represent Sita's House, bus stop, traffic signal and school respectively. In the morning Sita travels from A to B on foot, then B to D via C in the school bus. (All the values mentioned in graph are in km) Then calculate:

- (a) Distance traveled by Sita on foot,
- (b) Distance traveled by Sita by the school bus,
- (c) Total displacement of Sita from her house to the school.

2.5. Equations of Motion

When an object moves with constant acceleration, its motion can be described using equations which are given as:

$$V = u + at$$

$$S = ut + \frac{1}{2}at^2$$

$$v^2 = u^2 + 2as$$

where, u is initial velocity, v is final velocity, a is acceleration, and s is displacement.

Activity 2.5: Observing Accelerated Motion Using a Toy Car

Materials: Toy car (or small wheeled object), smooth floor, measuring tape, stopwatch (mobile timer), chalk/tape

Steps:

1. Mark a straight line on the floor and label the starting point as O.
2. Place the toy car at point O and give it a gentle push so that it moves forward.
3. Use a stopwatch and note the position of the car at equal time intervals (every 1 second).
4. Mark these positions on the floor using chalk or tape.
5. Measure the distance from the starting point to each marked position and record it in a table.

Observation: The distance travelled in successive intervals increases, showing acceleration.

Conclusion:

The motion is **accelerated motion**, as the velocity increases with time.

4th equation of motion distance travelled in the n^{th} second

From the **second equation of motion**:

$$s = ut + \frac{1}{2}at^2$$

where,

u = initial velocity

a = acceleration

t = time

s = displacement in time t

Distance travelled in n seconds

$$s_n = u(n) + \frac{1}{2}an^2$$

Distance travelled in (1) second

$$s_{n-1} = u(n-1) + \frac{1}{2}a(n-1)^2$$

Distance travelled in the n^{th} second

$$\text{distance in } n^{\text{th}} \text{ second} = s_n - s_{n-1} = \left[\frac{1}{2}an^2 \right] - \left[u(n-1) + \frac{1}{2}a(n-1)^2 \right]$$

Solving:

$$= un + \frac{1}{2}an^2 - un + u - \frac{1}{2}a(n^2 - 2n + 1) = u + \frac{1}{2}a[2n - 1]$$

Final Formula

$$s_n = u + \frac{a}{2}(2n - 1)$$

This is the distance travelled in the n^{th} second, often called the fourth equation of motion. Here n must be a positive integer representing the n th second of motion. The formula gives the displacement specifically during that one-second interval, not a cumulative displacement.

2.6 Reflect and Discuss

- Why is specifying a reference frame necessary to describe motion?
- How do direction and magnitude together describe displacement?
- Which daily activities around you involve accelerated motion?

2.7 Project-Based Learning

Design a simple experiment using everyday materials to measure the speed of a moving object (using a bicycle, or a walking student). Present your method, observations, calculations, and conclusions to the class.

Check Your Understanding

1. Define a frame of reference in your own words.
2. Give two real-life examples where motion depends on the observer.
3. Why does a person sitting in a moving train appear at rest to another passenger?
4. Classify the following as scalar or vector quantities: speed, velocity, displacement, distance, acceleration and mass.

5. Explain the difference between distance and displacement with an activity diagram.
6. Give two everyday examples of vector quantities.
7. Draw two vectors of 4 units east and 3 units north and find the resultant using the triangle method.
8. Explain how vector subtraction is performed graphically.
9. Draw two opposite vectors of equal magnitude. Calculate its resultant.
10. A body starts from rest and accelerates at 4 m/s^2 . Find the distance travelled in the 6th second.
11. A car with initial velocity 8 m/s accelerates at 2 m/s^2 . Find the distance covered in the 5th second.

Newton's Laws of Motion

3.1 Limitations of Newton's Laws in Accelerating Frames

Activity 3.1: Let us observe

Consider the following situations:

- A passenger standing in a bus that suddenly accelerates forward feels pushed backward, even though no one is actually pushing.
- When a vehicle takes a sharp turn, passengers feel pushed outward.

Why does this happen? Is there really a force pushing the passenger backward or outward? Can these effects be explained only by the usual forces like gravity or friction?



Understanding the Limitations

According to Newton's First Law of Motion, a body continues to remain at rest or in uniform motion in a straight line unless acted upon by an external force. This law is strictly valid only in a non-accelerating frame.

However, when the frame itself is accelerating, objects seem to move without any visible external force acting on them.

To maintain consistency with Newton's laws, let us examine an additional concept.

Pseudo Force (Fictitious Force)

A force which does not arise due to physical contact or interaction (unlike gravitational, frictional, or tension forces). A pseudo force (also called a fictitious force) is an apparent force that is observed only when motion is described from an accelerating frame of reference.

Now understanding the scenario: What does a passenger fall backwards when a bus starts suddenly?

Observer 1: Standing on the road (inertial frame)

- Sees the bus accelerate forward
- Sees the passenger trying to remain at rest (inertia)

Explanation uses only real physics:

- No backward force exists
- Passenger's body just resists motion

This follows Newton's First Law of Motion perfectly.

Observer 2: Inside the accelerating bus (non-inertial frame)

- Sees the passenger "move backward"
- But doesn't see any real force causing it

To make Newton's Laws of Motion still work, we **introduce the concept of pseudo force**: From the ground (an inertial frame), no force pushes the passenger backward — the bus simply accelerates away from under them. But if we describe the situation from inside the accelerating bus (a non-inertial frame), we must add a pseudo force of magnitude $m \cdot a$ directed backward to make Newton's First Law appear valid within that frame. This force has no physical source and no reaction pair.

When a frame accelerates forward, it exerts an influence on objects inside it. From within that accelerating frame, we introduce an imaginary force acting in the opposite direction to explain the observed motion. Thus, in an accelerating frame:

- The frame accelerates in one direction.
- An apparent force (pseudo force) is considered to act on the body in the opposite direction.

This ensures that Newton's First Law still appears valid within that frame.

Definition:

A pseudo force is an apparent force observed only in an accelerating frame of reference.

It is always opposite to the acceleration of the frame and does not arise due to any physical interaction.

Formula

$$F_{pseudo} = -ma_{frame}$$

where:

- m = mass of the object
- a_{frame} = acceleration of the frame
- The negative sign indicates that the pseudo force acts opposite to the acceleration of the frame.

Quick Check

1. In which type of reference frame are Newton's laws valid?
2. Define pseudo force and write its formula.
3. A lift accelerates upward at 4.5 m s^{-2} . Calculate the pseudo force experienced by a 60 kg person inside the lift.
4. Why does pseudo force disappear in an inertial frame?

3.2 Gravitation

Orbital Motion: Why the Earth and Moon Do Not Fall Despite Gravity?

Concept of Centripetal and Centrifugal forces

The Sun and the Earth both have mass, so they attract each other with a gravitational force. According to Newton's law of gravitation, the force between them is equal in magnitude and opposite in direction. However, because the Sun's mass is much greater than the Earth's mass, the Earth experiences a much larger acceleration as compared to the Sun. That is why the Earth appears to revolve around the Sun.

The Sun's gravitational pull on the Earth provides the centripetal force needed to keep the Earth in its orbit.

Earth is revolving around the Sun and it is moving with very high tangential velocity. So, due to its inertia, it should tend to continue moving in a straight line. On the other hand, the gravitational force of the sun is continuously attracting it towards the centre of the sun. This changes its direction of motion. As a result of these two aspects, the Earth does not move in a straight line but follows a fixed curved path called an orbit.

Let us think: Imagine the Earth suddenly slows down. Take a moment to picture what would happen if its forward (tangential) speed decreases, but the Sun's gravitational pull remains just as strong as before. Would the balance still exist? How would this change affect the Earth's path? Think about why slowing down would cause the Earth to drift closer to the Sun instead of continuing smoothly along its usual orbit.

Try to get the answer with the help of the following activity.

Activity 3.2:

Steps:

1. Tie the ring/bob securely to one end of the thread of length approx. 1 m.
2. Hold the other end of the thread firmly with your finger.
3. Swing the ring/bob in a horizontal circle at a steady speed.

4. Observe how the bob moves in a circular path.
5. Now slowly reduce the speed of rotation.
6. Continue decreasing the speed further and observe what happens to the circular motion.

Observation:

At an appropriate speed, the thread provides the centripetal force that pulls the stone/ bob inward, keeping it in a circular path. At the same time, due to its inertia, the stone tends to move in a straight line along the tangent. The balance between this outward tendency and the inward centripetal force results in circular motion.

When the speed decreases, the **required centripetal force also decreases**. However, the tension in the thread may reduce to the point where it can no longer keep the stone moving in a circular path. As a result, the string may become slack, and the motion is no longer circular—the stone begins to move inward or fall.

Conclusion:

Circular motion requires a balance between inward pulling force (centripetal force) and tangential speed (which provides necessary centrifugal force). If speed decreases too much, the balance is disturbed, and the object can no longer continue in the same circular path.

Effect of Cross-Sectional Area (Air Resistance) on Falling Objects of Equal Mass

Let us imagine two objects with the same mass but different cross-sectional areas. These are dropped from the same height, an important question arises: *Will they reach the ground at the same time?*

Case 1: When Air Is Present

Both objects have the same mass, so the gravitational force acting on them is the same:

$$F = mg$$

Since mass (m) is the same, the force of gravity on both objects is equal. This means gravity pulls both objects downward equally.

However, another force also acts on the objects — **air resistance (air drag)**. This is an upward force that opposes motion.

Air resistance mainly depends on the **cross-sectional area** of the object (and shape, speed and density of air). The larger the cross-sectional area, the greater the air resistance.

Because of this:

- The object with a **larger cross-sectional area** experiences more air resistance.
- The object with a **smaller cross-sectional area** faces less opposition.
- Therefore, it has a greater net downward force and falls faster.

Conclusion:

In air, the object with the **smaller cross-sectional area** reaches the ground first.

Case 2: In a Vacuum (No Air)

Since there is no air in a vacuum, there is **no air resistance either**.

$$a = \frac{F}{m} = \frac{mg}{m} = g$$

Conclusion:

In a vacuum, both objects reach the ground at the **same time**, regardless of their shape or size.

Variation of acceleration due to Gravity with Altitude and Depth (without using Binomial Theorem)

- When we throw a ball upward, it comes back down.
- When we jump, we return to the ground.

This happens because the Earth pulls everything toward its centre due to gravity.

But why do astronauts float inside a spacecraft?

Does gravity disappear in space?

Is the value of gravity the same everywhere?

We know that as we go higher above the Earth's surface, we move farther away from the centre of the Earth. We know that gravitational force depends on distance. As distance increases, force decreases.

Astronauts in the International Space Station appear weightless.

So clearly, gravity decreases with height, but it does not become zero.

Now let us derive the expression for the acceleration due to gravity at point A, which is at a height of h from the surface of the earth.

Derivation – Acceleration Due to Gravity at Height

Let:

- Mass of object = m
- Radius of Earth = R
- Height above surface = h
- Distance from centre of Earth = $(R + h)$

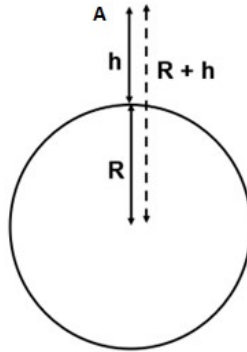

Fig: 3.1 Acceleration due to gravity at height h

The acceleration due to gravity at height h is:

$$g_h = \frac{GM}{(h)^2}$$

Where:

- G = Universal Gravitational Constant
- M = Mass of Earth

On Earth's surface:

$$g = \frac{GM}{R^2}$$

Dividing both equations:

$$\frac{g_h}{g} = \frac{R^2}{(h)^2}$$

This shows clearly that:

$$g_h < g$$

Example

Calculate acceleration due to gravity at a height of 800 km above Earth.

Given:

$$R = 6400 \text{ km}$$

$$h = 800 \text{ km}$$

$$g = 9.8 \text{ m/s}^2$$

$$g_h = g \left(\frac{R^2}{(h)^2} \right) g_h = 9.8 \left(\frac{6400^2}{7200^2} \right) g_h = 9.8 \left(\frac{64}{72} \right)^2 g_h = 7.74 \text{ m/s}^2$$

Acceleration Due to Gravity Below the Surface of Earth

Now, consider a point **A** located at a depth **d** inside the Earth. Assuming the Earth has uniform density, let us determine the acceleration due to gravity at that interior point.

Let:

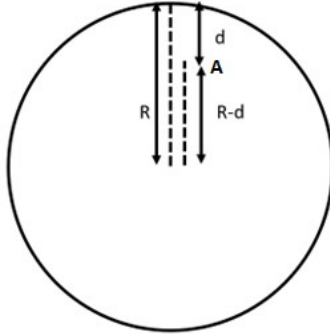

Fig: 3.2 Acceleration due to gravity at depth d

- Radius of Earth = R
- Depth below surface = d
- Distance from centre = (R - d)
- Density of Earth = ρ (uniform)

If density is uniform, then mass of the earth can be calculated by

$$\text{Mass of Earth} = M = \frac{4}{3} \pi R^3 \rho$$

At depth d, the object is at a distance (R - d) from the centre, only the mass inside radius (R - d) contributes to gravity. (This is By Newton's Shell theorem, the gravitational effect of a uniform spherical shell on a point inside it is exactly zero. Therefore, at depth d, only the sphere of radius (R-d) centred at Earth's core contributes to gravity—the outer shell of thickness d has no net effect)

$$M_d = \frac{4}{3} \pi (R - d)^3 \rho$$

From Newton's Law of Gravitation

$$g_d = \frac{GM_d}{(d)^2}$$

Substitute M_d :

$$g_d = \frac{G \left(\frac{4}{3} \pi (R - d)^3 \rho \right)}{(d)^2}$$

$$g_d = \frac{4}{3} \pi G \rho (R - d)$$

Compare with gravity at earth's surface i.e.

At Earth's surface:

$$g = \frac{4}{3} \pi G \rho R$$

Dividing the two equations:

$$\frac{g_d}{g} = \frac{R - d}{R}$$

Therefore,

$$g_d = g \left(\frac{d}{R} \right)$$

We conclude from the above derivations that acceleration due to gravity is maximum at the Earth's surface and decreases as we go up/down. It will become zero at the centre of the earth.

Example:

At what depth does g become 1/10th of its surface value?

Given:

$$g_d = \frac{g}{10}$$

Using the formula:

$$g \left(\frac{d}{R} \right) = \frac{g}{10} \Rightarrow 1 - \frac{d}{R} = \frac{1}{10} \Rightarrow \frac{d}{R} = \frac{9}{10} \Rightarrow d = \frac{9R}{10}$$

Quick Check

1. Where does the acceleration due to gravity reach its maximum value—on the surface, above, or below the Earth?
2. What happens to g at the centre of the Earth?
3. Calculate g at a height of 400 km if R = 6400 km.
4. At what depth will g become half of its surface value?
5. Why does gravity decrease both above and below the surface of the earth?

3.3 Turning Forces (Moment of Force/Torque)

Activity 3.3: Let us observe

Look at the picture of a boy trying to enter his classroom. He pushes the door to open it.



Now, think carefully and answer the following questions:

- Where will the boy apply force to open the door easily?
 - (a) Near the handle
 - (b) Near the hinges
 - (c) At the centre of the door
- Why are door handles fixed far away from the hinges and not near them?

Now, reflect on the following points:

- The boy applies force in a straight direction, but the door rotates. Why does this happen?
- Even though the door is heavy, it rotates easily when pushed at the handle.
- How is it possible to rotate such a heavy object by applying force at just one end?

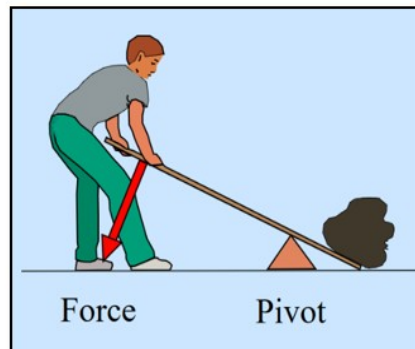
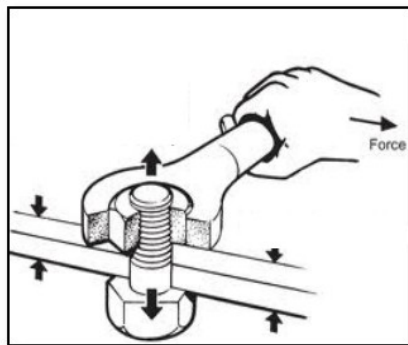

Fig: 3.3 Some examples of turning effects of forces in our daily life

When we apply a force to an object and it starts to rotate, the force produces a turning effect.

This turning effect of a force is called the moment of force.

Moment of Force (Torque) $\tau = F \times d \times \sin \theta$, where F is the magnitude of the force, d is the distance from the pivot to the point of application, and θ is the angle between the force and the line joining the pivot to the point of application. Torque is maximum when $\theta = 90^\circ$ (force perpendicular to the lever arm) and zero when $\theta = 0^\circ$ or 180° (force directed toward or away from the pivot).

Since the turning effect of a force depends on both the magnitude of the force and the distance from the fixed point, its S.I. unit is newton-metre (Nm).

The angle at which force is applied to a door (and the resulting angle of the door itself) is crucial for controlling the turning, efficiency, and safety of the opening motion. The fundamental principle is that turning is maximized when the force is applied perpendicular (at a 90-degree angle) to the door surface, making it the most efficient way to open or close it.

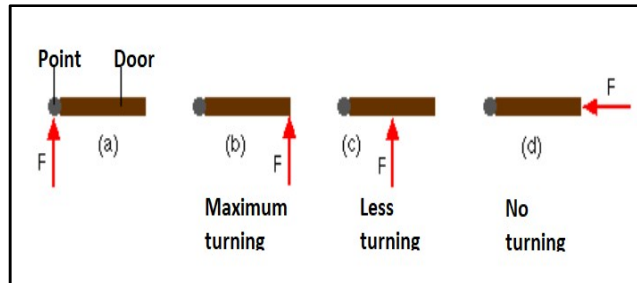

Check Your Understanding

1. Why is it easier to open a door when you push at the handle rather than near the hinges?
2. A force is applied to a wrench at different angles. At which angle will the rotating force be maximum? What happens to the turning effect when the force is applied parallel to the wrench?
3. Two students apply the same force to open a gate. One pushes perpendicular to the gate at 20cm from the hinge. The other pushes perpendicular to the gate at 80 cm. Who produces greater torque? Justify
4. Is it possible for a force to act on a body and still produce zero turning about a given fixed point? Give a real-life example.
5. Two forces act on a rod pivoted at its centre:
 - I. 10 N downward at 0.5 m on the left
 - II. 10 N downward at 0.5 m on the right
 Will the rod rotate? Explain your reasoning
6. How can a mechanic loosen a tight bolt using a long spanner instead of applying a very large force? Explain using the torque formula.
7. A force of 20 N is applied to a door at 0.8 m from the hinge. Calculate the torque when the force is applied at (a) 90°, (b) 60° (c) 30° to the door surface.

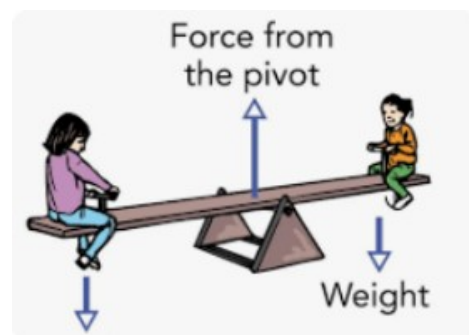

The Geometry of Power- Advanced Simple Machines

4.1 Introduction

Welcome to the study of Mechanical Advantage. While simple machines such as levers and inclined planes form the foundational concepts of physics, the machines that shape our modern world—like cranes, trucks, and bicycles—apply these same principles in more advanced and integrated ways through systems of wheels, axles, and pulleys.

In this chapter, we will examine how the principles of geometry and force distribution allow a relatively small input force to be transformed into a much larger output force.

Activity 4.1:

- A truck driver turning a massive vehicle using only two hands.
- A crane lifting heavy concrete beams smoothly.
- A cyclist moving very fast by pedaling lightly.

Now think carefully:

- Is the driver extremely strong?
- Does the crane create extra force?
- Does the cyclist get “free” speed?

In all these cases, machines are helping us multiply force or increase speed.

This multiplication is called **Mechanical Advantage (MA)**.

4.2 Wheel and Axle – The Steering Mastery

Activity 4.2: Think and Answer

“Think about a steering wheel and axle (steering column) and their respective radius.”

- The steering wheel is large. The steering column connected to it is small. Why is this so?
- Why not make both of equal size?

A wheel and axle consist of:

- a large wheel
- a smaller axle fixed at the center

Both rotate together. When effort is applied on the wheel, torque increases at the axle.

The Mechanical Advantage is calculated using the formula:

$$M.A = \frac{\text{Radius of wheel}}{\text{Radius of Axle}}$$

Example

A driver needs to maneuver the truck on muddy ground, requiring a resistance force of 1,200 N to turn the steering axle. The steering wheel has a radius of 30cm, and the steering axle has a radius of 3cm.

- a) Calculate the Mechanical Advantage (MA) of the steering system.
- b) How much effort (E) must the driver apply to the rim of the steering wheel to turn the truck?

Solution:

$$\begin{aligned} \text{a) } M.A &= \frac{\text{Radius of wheel}}{\text{Radius of Axle}} \\ &= \frac{30 \text{ cm}}{3 \text{ cm}} = 10 \end{aligned}$$

$$\begin{aligned} \text{b) } \text{Effort (E)} &= \frac{\text{load}}{M.A} \\ &= \frac{1200N}{10} = 120N \end{aligned}$$

The driver needs to apply an effort of 120N to the rim of the steering wheel to turn the truck.

Note: In practice, some input work is lost to friction within the machine. The efficiency of a machine is defined as $\eta = (\text{useful output work} / \text{total input work}) \times 100\%$. A real machine always has $\eta < 100\%$. Mechanical Advantage as calculated here assumes an ideal (frictionless) machine.

Quick Check

In a mechanical watch, a single power source (a spring or motor) must move three different hands at three different speeds. This is achieved through a **Gear Train**, where the "output" of one gear becomes the "input" for the next. The seconds-to-minutes gear ratio is 60:1 and the minutes-to-hours ratio is 60:1;

1. If the seconds gear is 2 mm, how large would the hour gear be in meters?
2. Which of the three hands gear should be directly connected to the motor? Why?

4.3 Tension

Activity 4.3:

Hang a thread from an iron stand as shown in figure. Observe its natural length.

Now attach a small bob to the lower end of the thread. Notice how the thread stretches slightly.

Replace the small bob with a heavier bob. Does the stretch increase or decrease?

You will observe that the thread stretches more when a heavier bob is attached. This shows that a greater pulling force is acting on the thread.



Further,

Pass the thread over a pulley. Attach a weight to one side and observe.

Now attach equal weights (equal bobs) on both sides of the pulley. Does the rope move, or does it only stretch?

Replace one of the equal bobs with a heavier bob on the left side. Observe carefully the direction in which the system moves.

When both sides have equal weights, the system remains at rest because the forces are balanced. When one side is heavier, the system moves toward the heavier side.



Tension

Tension is the pulling force/ stretch force that travels through a stretched string, thread, rope, or cable. When you hang an object using a thread, the object pulls the thread downward because of its weight. In response, the thread pulls the object upward. This pulling force inside the thread is called tension. If the weight attached to the string increases, the tension in the string also increases.

It always acts along the length of the string and pulls away from the object to which it is attached.

S.I unit of tension is Newton.

When the forces acting on an object are balanced (for example, the upward tension is equal to the downward weight), the object remains at rest or moves with constant speed. This state is called **equilibrium**. In a pulley system, if equal

weights are placed on both sides, the tensions balance and the system does not move. But if one side is heavier, the forces become unbalanced, and the system moves toward the heavier side. This is by Newton's First Law of Motion.

Let us Calculate: Tension and acceleration are produced when two unequal masses are connected over a pulley.

1. Do the setup of weights, string and simple pulley as shown.

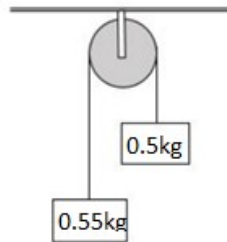

2. Since $0.55 \text{ kg} > 0.5 \text{ kg}$, the 0.55 kg mass will move downward. The 0.5 kg mass will move upward. Both masses will move with the same acceleration because they are connected by the same string.
3. For 0.55 kg mass (moving downward):
 - a. Downward force = Weight = _____
 - b. Upward force = Tension (T)
4. Net force: $0.55g - T = 0.55a$
5. For 0.5 kg mass (moving upward):
 - a. Downward force = Weight = _____
 - b. Upward force = Tension (T)
6. Net force: $T - 0.5g = 0.5a$
7. Add both equations: _____
8. Acceleration of the system: _____
9. Find Tension: _____

Examples:

1. A 5 kg object is suspended stationary from a rope. Calculate the tension.

Ans: The weight of the object is: $T = m \times g = 5 \times 9.8 = 49 \text{ N}$

2. A 4 kg mass is lifted upward with an acceleration of 2 m/s^2 . Calculate the tension.

Ans: Using Newton's Second Law

$$T - mg = ma \quad T = m(g + a) \quad T = 4(9.8 + 2) \quad T = 47.2 \text{ N}$$

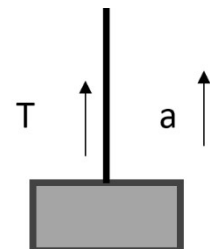

Check Your Understanding :

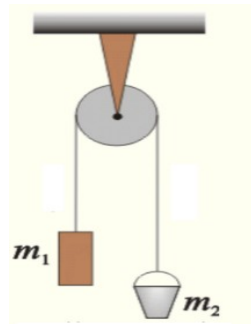

1. Show the direction of weight and tension for both objects m_1 and m_2 .
2. An 8 kg mass hangs freely from a single fixed pulley. The system is at rest. Find the tension in the rope.
3. Observe the given diagram. Find out in which direction the rope will move? What will be the net downward force?

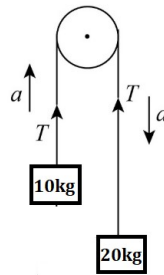

4. A 6 kg mass hangs freely from a single fixed pulley. The system is at rest. Find the tension in the rope.
5. Two objects having masses 2 kg and 6 kg are connected over a frictionless pulley with the help of rope. Find acceleration and tension in the rope.

Work and Energy

5.1 CONSERVATIVE AND NON-CONSERVATIVE FORCES

Recollect these common occurrences:

- A ball thrown upward comes back down to your hand.
- A stretched rubber band returns to its original shape.
- A sliding book on a table finally stops.

Now think carefully:

- Why does the ball come back?
- Why does the rubber band regain its shape?
- Why does the book stop moving?

In all these cases, forces are acting. But are all these forces the same?

Conservative Forces

- If the work done by the force doesn't depend on the path.
- Work done by the force on the closed path is always zero.
- For a conservative force, the work done by the force equals the decrease in potential energy: $W = -\Delta U = -(U_{\text{final}} - U_{\text{initial}}) = U_{\text{initial}} - U_{\text{final}}$. Equivalently, $\Delta U = U_{\text{final}} - U_{\text{initial}} = -W$.

Examples: Gravitational force (Earth pulling objects downward) and Spring force (stretched or compressed spring)

Non-Conservative Forces: If the work done by the force depends on the path taken.

Examples: Friction (solid and drag)

When you slide a book across a table, it eventually stops because friction converts its kinetic energy into heat. This lost energy cannot be fully recovered.

That is why friction is a non-conservative force.

Reflect on the following:

- If there were no friction, would a moving object ever stop?
- Why do pendulums slowly stop after some time?
- Why do machines require lubrication?

Quick Check

1. Define a conservative force with one example.
2. Why is gravitational force called a conservative force?
3. Why is friction called a non-conservative force?
4. What happens to energy when a non-conservative force acts on an object?
5. If there were no friction on Earth, how would motion be different? Explain.

5.2 Potential Energy of a Spring

Activity 5.2:

Collect the following items: A spring, a stand, a weight hanger, slotted weights, a ruler.

1. Suspend a spring vertically from a rigid support.
2. Attach a weight hanger to the free end of the spring and note the initial length of the spring.
3. Add a known weight to the hanger and measure the extension produced in the spring.
4. Increase the weight gradually and note the corresponding extension each time.
5. Repeat the experiment using springs made of different materials or thickness.

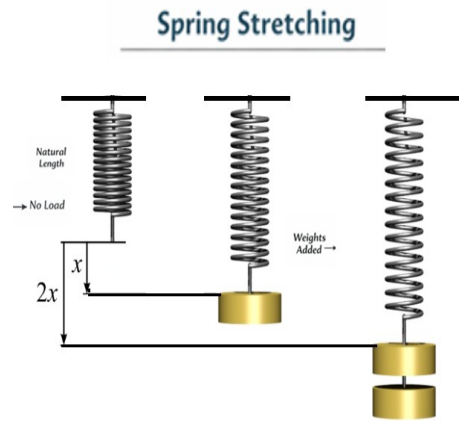

Observation:

- As more weight is added, the extension of the spring increases.

Different springs show different extensions for the same applied weight.

Conclusion:

The extension of a spring is directly proportional to the applied force (weight), provided the elastic limit is not exceeded. This relationship can be expressed as:

$$F = kx$$

where

F = applied force,

x = extension produced,

k = spring constant, which depends on the nature of the spring.

This law is called Hooke's law and is mathematically stated as $F = -kx$. The negative sign indicates the force is a restoring force acting against the direction of displacement (elongation or compression), aiming to return the spring to its original length.

Its unit is N m^{-1} . The spring is said to be stiff if k is large and soft if k is small.

Derivation

- The spring obeys Hooke's Law

$$F \propto x$$

$$F = kx$$

Prepare a graph between Force and extension in the spring with the help of data observed in the activity by taking

- X-axis → Extension (m or cm)
- Y-axis → Force (N)

Observation Table

These values give a straight-line graph passing through origin.

Sample Values for $k = 100 \text{ N/m}$

| Force (F) in N | Extension (x) (in cm) | Extension (x) (in m) |
|----------------|-----------------------|----------------------|
| 0 | 0 cm | 0 m |
| 20 | 20 cm | 0.2 m |
| 40 | 40 cm | 0.40 m |
| 60 | 60 cm | 0.60 m |
| 80 | 80 cm | 0.80 m |
| 100 | 100 cm | 1 m |

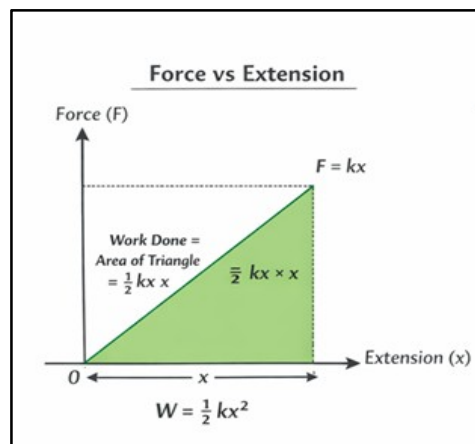

Calculation of Average Force:

For a spring stretched from 0 to maximum force:

$$\text{Average Force} = \frac{F_{\text{initial}} + F_{\text{final}}}{2}$$

When the spring is stretched gradually from zero extension to a maximum extension x , the force acting on it does not remain constant.

- At the beginning, force = 0
- At extension x , force = kx

So, the average force (spring force changes linearly from 0 to maximum as extension increases.) acting on the spring is given by:

$$F_{average} = \frac{0 + kx}{2} = \frac{kx}{2}$$

Work done in stretching the spring = Average force × Extension

$$W = \frac{kx}{2} \times x = \frac{1}{2}kx^2$$

Conclusion

The work done in stretching the spring is stored in it as elastic potential energy.

$$U = \frac{1}{2}kx^2$$

Example: A spring obeys Hooke's law with a spring constant of 30 N m^{-1} . If a force of 100 N is applied to the spring, calculate the extension produced in the spring. The Force-extension graph of a spring of spring constant 100 N m^{-1} is given in figure:

- Using the graph, determine the work done in stretching the spring from 2 cm to 6 cm .
- If the spring is released from the stretched position of 6 cm , calculate the maximum speed of a body of mass 0.5 kg attached to the spring, assuming no loss of energy.

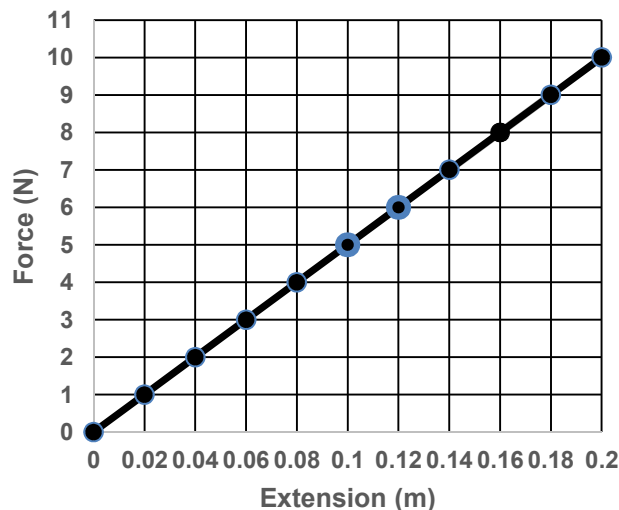

Solution:

- Work done = area under force-extension graph

$$W = \frac{1}{2}k(x_2^2 - x_1^2)$$

$$W = \frac{1}{2} \times 100 \times (0.06^2 - 0.02^2)$$

$$W = 50 \times (0.0036 - 0.0004)$$

$$W = 50 \times 0.0032 = 0.16 \text{ J}$$

(b) $k = 100 \text{ N/m}$, $x = 0.06 \text{ m}$. Elastic PE = $\frac{1}{2} \times 100 \times 0.06^2 = 0.18 \text{ J}$. At maximum speed, all PE converts to KE: $0.18 = \frac{1}{2} \times 0.5 \times v^2$, so $v^2 = 0.72$, $v \approx 0.85 \text{ m/s}$.

Check Your Understanding

- 1) Explain the conversion of potential energy to kinetic energy when a ball is thrown upward.
- 2) Why is gravitational potential energy considered a conservative force?
- 3) Calculate the potential energy of a 5 kg object kept on the top of a 30m high building. (Considering potential energy to be zero at the base of the building.)
- 4) What is the increment in its potential energy?
- 5) A 10 kg weight is hung from a 5 m wire, causing it to stretch by 1 mm. Calculate the energy stored.
- 6) Calculate the work done by an external force to lift a 2 m long rod from a horizontal to a vertical position.

Structure Of Atom

6.1 Discovery of Subatomic Particles

You have learnt about the development of models of the structure of the atom. You would recall that in 1803, Dalton proposed that atoms are the smallest indivisible particles of matter. However, this idea could not explain the results of several experiments. For example, it was observed that substances like glass or ebonite, when rubbed with silk or fur, acquire electric charge. This and many other experiments on electrical discharge through gases showed that atoms are not indivisible. They are made up of smaller particles called subatomic particles.

J. J. Thomson, in 1897, discovered the electron as a constituent of the atom and confirmed that the atom is not the smallest particle of matter. He proposed the so-called plum-pudding model of the atom, in which electrons are embedded in a sphere of positive charge. This model was later shown to be incorrect by Rutherford, as it could not explain the results of the gold foil experiment. Rutherford then proposed a model in which electrons revolve around a small, positively charged nucleus. However, this model could not explain the stability of the atom. Thereafter, another model was proposed by Niels Bohr.

Here, you will learn about the discovery of the subatomic particles—electron, proton, and neutron—which contribute to our understanding of atomic structure. Before discussing these exploration we must recall a basic principle: like charges repel each other, while unlike charges attract each other.

6.1.1 Discovery of Electron

In the late nineteenth century, many scientists, including Michael Faraday, William Crookes, and others, studied electrical discharge in partially evacuated tubes known as cathode ray discharge tubes. J.J Thomson carried out experiments by taking gases at low pressure in discharge tube which is a long glass tube in which two metal plates connected to oppositely charged poles of battery (Fig 1)

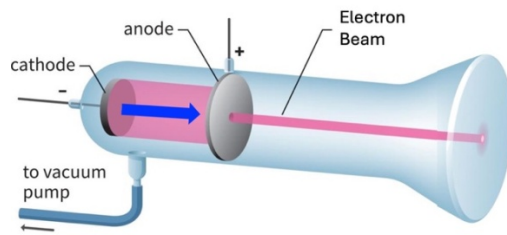

Fig. 6.1: A schematic representation of cathode ray tube showing the cathode rays going from the cathode to anode in a straight line

When a sufficiently high voltage is applied across the electrodes, rays are observed to travel from the negatively charged electrode (cathode) towards the positively charged electrode (anode). (Fig 2)

These are called cathode rays. The presence of these rays can be detected by allowing them to pass through a hole in the anode and strike at screen coated with a special material placed behind it. A bright spot is observed on the screen, indicating that the rays travel in straight lines.

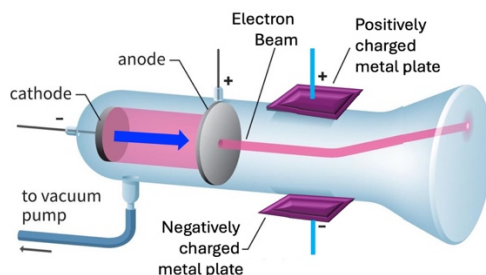

Fig.6.2: A schematic representation of the deflection of cathode rays to positive plate of the applied electric field.

Further to determine the nature of these rays, Thomson carried out experiments by applying electric and magnetic fields in the path of the rays. He observed that the rays were deflected towards the positively charged plate.

This showed that the particles in the rays carry negative charge on further experimentation. Thomson concluded that cathode rays consist of tiny negatively charged particles, later called electrons.

When these experiments were repeated using different gases (such as hydrogen, nitrogen, neon, etc.) and different electrode materials, it was found that the properties of cathode rays remained unchanged. This showed that electrons are present in all atoms.

The main characteristics of cathode rays are as follows:

- They originate from the cathode and move towards the anode.
- They are not visible themselves but produce bright spot when they strike certain materials.
- They travel in straight lines in the absence of external fields.
- They are deflected by electric and magnetic fields in such a way that indicates them to be negatively charged.
- Their properties do not depend on the nature of the gas or the electrode material.

Thus, electrons are a fundamental constituent of all atoms.

6.1.2 Discovery of Protons

After the discovery of the electron, it was realised that since electrons are negatively charged, atoms must also contain positive charge to maintain electrical neutrality.

Eugen Goldstein, in 1886, performed experiments using a discharge tube similar to that used for cathode rays, but with a cathode having holes in it (perforated cathode). When high voltage was applied, a faint glow was observed behind the cathode. The rays responsible for this glow passed through the holes (or canals) in the cathode and were therefore called canal rays.

Further studies showed that these rays were deflected towards the negatively charged plate in electric and magnetic fields, indicating that they consist of positively charged particles.

However, it is important to note that canal rays are not made up of a single type of particle. They consist of positively charged ions of the gas present in the tube. Therefore, their properties depend on the nature of the gas used.

When hydrogen gas was used in the discharge tube, the positively charged particles obtained were the lightest known and were identified as hydrogen ions (H^+). These particles were later recognised as protons. The proton was finally established as a fundamental particle by Rutherford in 1919.

The main characteristics of canal rays are:

- They are positively charged.
- Their behaviour in electric and magnetic fields is opposite to that of electrons.
- Their properties depend on the nature of the gas present.
- The lightest positive particle was obtained from hydrogen and is called the proton.

6.1.3 Discovery of Neutrons

Once electrons and protons were known, it appeared that the structure of the atom was understood. However, another problem arose when atomic masses were measured. The mass of atoms was found to be greater than the sum of the masses of their protons and electrons. For example, helium contains two protons, yet its mass is about four times that of hydrogen. This indicated the possibility of the presence of another particle contributing to the mass of the atom.

It was proposed that there must be a neutral particle present in the atom. This particle was discovered by James Chadwick in 1932. He bombarded a thin sheet of beryllium with alpha particles and observed the emission of powerful neutral

radiation. This radiation consisted of particles having no charge and a mass nearly equal to that of the proton. These particles were called neutrons.

Neutrons are present in the nuclei of almost all atoms. The most common isotope of hydrogen that does not contain a neutron is protium (${}_1\text{H}^1$) but its heavier isotopes Deuterium (${}_1\text{H}^2$) and Tritium (${}_1\text{H}^3$) contains neutrons.

Thus, the presence of neutrons explains the mass of atoms. For example, helium contains two protons and two neutrons, which accounts for its mass being approximately four times that of hydrogen.

Chadwick was awarded the Nobel Prize in Physics in 1935 for the discovery of the Subatomic particle neutron.

From these discoveries, it became clear that atoms are composed of three subatomic particles:

- Electrons (negative charge)
- Protons (positive charge)
- Neutrons (no charge)

These particles together determine the structure and properties of atoms.

Quick Check:

1. Why do cathode rays bend towards the positive plate?
2. What conclusion did Thomson draw from using different gases in discharge tubes?
3. Why are canal rays different from cathode rays in nature?
4. Why was the discovery of neutron necessary?
5. In a cathode ray experiment, it was observed that the rays bend towards a positively charged plate. What can we conclude about the nature of these rays?
6. In a discharge tube experiment, the gas is changed from hydrogen to neon, but the behaviour of cathode rays remains unchanged. What does this observation tell us about electrons?
7. If cathode rays were neutral instead of being negatively charged, how would their behaviour differ in an electric field?
8. In an experiment with canal rays, different gases are used and different masses of particles are observed. What conclusion can be drawn about the nature of canal rays?

9. Why did scientists feel the need to propose the existence of neutral particles even after discovering electrons and protons? Explain using the example of helium.
10. In Chadwick's experiment, the emitted particles were not deflected by electric or magnetic fields. What does this observation indicate about the nature of these particles?

6.2. Spectrum

When white light passes through a glass prism, what do we observe? We see a rainbow, that consists of a continuous spread of many colours from violet to red (VIBGYOR). Such a spread is called a **continuous spectrum** in which the colours are present without any gap.



Fig 6.3 Continuous Spectrum

Now, suppose we take a sodium vapour lamp, which you would have seen at street lights or in parks, and pass the 'yellow light' given out by it, through a prism. We find that we do not get all the colours but only a few bright coloured lines. Two of these are intense yellow lines. We may do a similar experiment with mercury vapour lamp and observe another set of distinct lines. Such a spectrum that contains distinct lines is called a **line spectrum**.



Fig 6.4 (a) Sodium vapour lamp



Fig 6.4 (b) Lines Spectrum of Sodium

Line spectrum means only specific radiation are emitted, not all. It is important to know that the line spectrum is characteristic of the element causing it. This fact is used to identify elements present in stars by studying their spectra. Even without going to the star, we can know what it is made of.

6.3 Line Spectrum of Hydrogen

Now, when the radiation from a discharge tube containing hydrogen gas in it is passed through a prism, it also gives line spectrum called **hydrogen atom spectrum**.

The Spectral lines for atomic hydrogen are:

| Series | n_i | n_f |
|----------|-------|--------------|
| Lyman | 1 | 2,3_ _ _ _ _ |
| Balmer | 2 | 3,4_ _ _ _ _ |
| Paschen | 3 | 4,5_ _ _ _ _ |
| Brackett | 4 | 5,6_ _ _ _ _ |
| Pfund | 5 | 6,7_ _ _ _ _ |

The energies of the distinct spectral lines observed in hydrogen atom spectrum could be expressed empirically in terms of mathematical expressions involving two sets of integers. This equation is known as Rydberg Equation.

$$\Delta E = R_E Z^2 \left(\frac{1}{n_f^2} - \frac{1}{n_i^2} \right),$$

$$R_E = 109,677 \text{ cm}^{-1}$$

Where, R_E is the Rydberg constant expressed in terms of energy and Z is the atomic number. These empirical formulas worked very well but could not be explained until Bohr's model came.

6.4 Limitation of Rutherford Model of Atom

- Rutherford could not explain stability as the electron continuously loses energy when it moves around the nucleus.
- As the electron in the atom is allowed to have continuous energies, therefore the emitted radiation is expected to give a continuous set of radiation. However, we observe a line spectrum. Therefore, we say that Rutherford's model fails to explain the existence of line spectrum of hydrogen.

6.5 Bohr's model

Neils Bohr, a student of Rutherford, in 1913 proposed his model for an atom. He combined Rutherford's nuclear model with the new quantum idea introduced by Max Planck. He made two revolutionary assumptions which are as below:

- Electrons can move only in certain allowed circular orbits without radiating energy. That is, they have a fixed energy as long as they are in a given orbit.
- The radiation is emitted or absorbed only when an electron jumps from one allowed orbit to another,

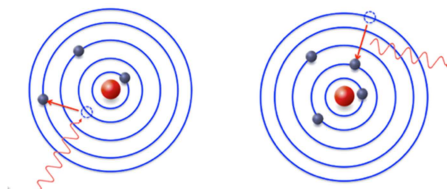

Fig 6.5:Energy change is electron jump

6.5.1 Achievement of Bohr Model

“When an electron jumps from an orbit of higher energy to that of a lower energy it releases energy in the form of radiation. The amount of energy released depends on the difference in the energies of the two levels. Since the orbits of only certain energies exist, only of fixed quantity energy differences are possible. Therefore, we get a line spectrum. Bohr’s model could explain the observed line spectrum of hydrogen fairly well.

6.5.2 Limitations of Bohr’s model

Bohr model was unable to explain:

- Finer details (that is closely spaced lines) of hydrogen atom spectrum observed by sophisticated spectroscopic techniques.
- The spectrum of atom other than hydrogen.
- The splitting of spectral lines in presence of magnetic field (Zeeman effect) or an electric field (Stark’s effect).

6.6 Check Your Understanding

1. The hydrogen spectrum consists of only a few sharp spectral lines instead of a continuous spectrum. What information does it provide about the energy of electrons in an atom.
2. Explain why would Rutherford’s model predict a continuous spectrum rather than a line spectrum.
3. A discharge tube filled with an unknown gas produces a line spectrum identical to hydrogen. What can you conclude about the gas? Give reason.
4. If electrons in an atom were allowed to have a continuous set of energy values, what kind of spectrum would you expect? Why is this not observed?
5. “Bohr’s model solved all problems of atomic structure.” Comment.
6. How does the concept of fixed energy levels explain the stability of atoms?

7. Why do different elements produce different line spectra? Give a conceptual explanation.
 8. Explain why Bohr's model works well for hydrogen but not for multi-electron atoms.
 9. State two limitations of Rutherford's model.
 10. Rutherford's model explained the structure of the atom but failed to explain atomic stability and spectra. Discuss.
 11. What was the main drawback of Rutherford's model regarding electron motion? What assumption was made by Bohr to overcome this problem.
 12. How does Bohr's model explain line spectrum of hydrogen?
 13. Outline the limitations of Bohr's model.
 14. Define line spectrum and continuous spectrum with one example each.
 15. Write two main postulates of Bohr's model.
 16. What is meant by fine structure in hydrogen spectrum?
 17. What is the significance of Rydberg equation?
-

Chemical Bonding

7.1 Octet Rule

You have learnt that the atoms having eight electrons in its valence shell are stable. The atoms other than hydrogen tends to form bonds until it is surrounded by eight valence electrons. They do so by gaining, losing or sharing electrons. It is called **Octet rule** and is quite useful in describing the formation of simple molecules. It is important to note that the octet rule is just a guiding principle and not a law. In case of hydrogen, the valence shell attains the electron configuration of helium, i.e., a total of two electrons.

7.1.1 Lewis Approach

Lewis Symbol :- The Valance electron of an atom in terms of dot is written around the atom.

For Example:

Fluorine (F=9) Electronic configuration=2,7

Valence electron=7

Hence is represented as:



Bonding in molecule:

Duing bonding the valance electrons are written around the atoms and then electrons are shared in such a way so as to complete the octet of each atom.

For Example the Lewis formula for Hydrogen Fluoride is

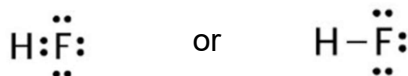

Here the pair of dots (representing electrons) placed between the symbols of the combining atoms represent the bonding electrons. The remaining dots represent the non-bonding electrons. As the name suggests, the non-bonding electrons do not contribute to the bonding. You may note that the hydrogen atom in this molecule has only two electrons (a duplet) around it. The line here indicates the bond between hydrogen and fluorine atom.

7.1.2 Exceptions of Octet Rule

Many stable molecules do not follow the octet rule. These are called exceptions to the octet rule. Let us discuss about these exceptions.

Molecules with incomplete octets

In case of some elements the valence shell has less than four valence electrons. In these cases, their atoms cannot form four bonds to complete the octet. Also, these do not have sufficient lone pairs that can complete the octet. As a result, the octet remains incomplete in such cases. For example, in case of lithium, beryllium and boron there are only 1, 2 and 3 valence electrons respectively. Therefore, these can form 1, 2 and 3 bonds respectively. In such cases the central atom would have 2, 4 and 6 electrons respectively on forming the molecule. These represent molecules which do not complete the octet and yet are stable. One common example is that of boron trifluoride. In this molecule, one boron atom makes bonds with three fluorine atoms and is represented as



The lines here indicate the bond between boron and fluorine atom.

Molecules with expanded octets

Another exception to the octet rule is observed in the formation of molecules having more than eight valence electrons around central atom. Such molecules are formed by the atoms of the elements having more than four electrons in their valence shell. For example, in case of sulfur hexafluoride one atom of sulphur combines with six atoms of fluorine. The Central sulphur atom has 12 electrons in its valence shell representing an expanded octet. We can represent its structure as



You will learn about the formation of such compounds in higher classes.

Molecules with odd number of electrons

Certain molecules have an odd number of electrons. For example, an atom of nitrogen (having 5 valence electrons) makes two bonds with an atom of oxygen (having six valence electrons) to form a molecule of NO. It has a total of 11 valence electrons, five from N and six from O atom. The Lewis structure for this molecule can be represented as



The two lines here indicate two bonds. Whenever there are odd number of electrons in a molecule then at least one atom would have an incomplete octet. Secondly in such a molecule there would always be an unpaired electron.

Quick Check

1. What is meant by the octet rule?
2. Why does hydrogen not follow the octet rule?
3. Give one example each of the molecule with
 - a) incomplete octet
 - b) expanded octet
 - c) an odd electron
4. Why can boron form compounds with only six electrons around it?
5. What is meant by a duplet configuration?
6. Why is NO considered an exception to the octet rule?
7. Draw the Lewis dot structure of BF_3 and explain why boron does not complete its octet.
8. Assertion: SF_6 violates the octet rule.
Reason: Sulphur can accommodate more than eight electrons.
 - A. Assertion and reason, both are correct and reason is the correct explanation of the assertion.
 - B. Assertion and reason, both are correct but reason is not the correct explanation of the assertion.
 - C. Assertion is correct but reason is a wrong statement.
 - D. Assertion is wrong but the reason is a correct statement.

7.2 Metallic Bonding

You all are familiar with metals like iron, copper, aluminium, and so on. They are hard, they can be beaten into sheets, drawn into wires, and they conduct electricity. You may be wondering how can we explain these properties of metals. We can explain these in terms of a simple model known as the electron sea model for metals. You have learnt about bonding in case of ionic and covalent compounds. In these, the atoms bind by transfer or sharing of electrons between specific atoms. The electron sea model, in fact, is a simple model for bonding in metals. It involves bonding between a very large number of atoms of the metal. Let us understand this model and learn how we can explain the properties of metals by using this model.

7.2.1 Electron Sea Model

A metal atom has a few electrons in its outermost shell. These outer electrons are not held very tightly by the nucleus. Because of this, when many metal atoms come together to form a solid, these outer electrons do not remain attached to any

one atom. Instead, they become delocalised and are free to move throughout the entire piece of metal.

You know that when an atom loses an electron it becomes a cation. In metals, the atoms can be thought of as forming positive metal ions arranged in a regular pattern. These ions form a kind of fixed structure. The free electrons move continuously and randomly in all directions around and between these ions. This collection of freely moving electrons is called a “sea of electrons”.

Thus, according to the electron sea model, a metal can be seen as a structure in which positive metal ions are fixed in place, and a “sea” of mobile electrons moves around them. This is why the model is called the electron sea model as shown in Fig.7.1.

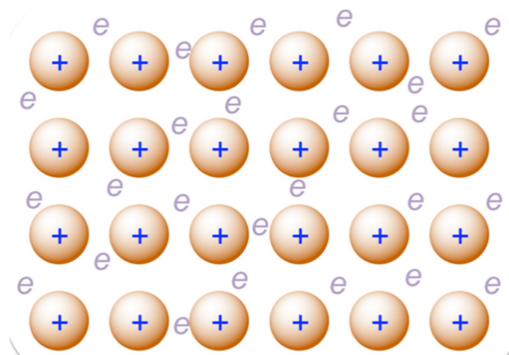

Fig. 7.1: Schematic representation of Electron sea model

These ions and electrons together form a stable structure. The attraction between the positive ions and the sea of electrons is what holds the metal together. This attraction is called **metallic bonding**. So, we can say that metallic bonding is the force of attraction between positive metal ions and the sea of electrons. It is important to note that unlike covalent bonds, metallic bonds are not localised. The electrons are shared by all the atoms collectively, forming a non-directional bond that can adjust to shifting positions of the metal ions.

7.2.1: Electron sea model and properties of metal

Now let us see how this simple electron sea model helps us to understand the properties of metals.

Electrical conductivity

Since electrons are free to move, when we apply an electric field across a metal, these electrons start moving in a particular direction. This movement of electrons is what we call electric current. That is why metals are good conductors of electricity.

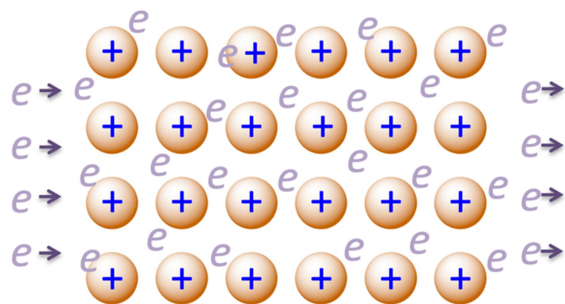

Fig.7.2: Schematic representation of electrical conduction by metals in terms of electron sea model

Thermal conductivity

When one part of a metal is heated, the electrons in that region gain energy and start moving faster. As they move, they transfer this energy to other parts of the metal. At the same time, the metal ions also vibrate more and help in passing the heat along. In this way, heat spreads quickly. This is why metals are good conductors of heat.

Malleability and Ductility

You know that malleability refers to the ability of metals to be beaten into thin sheets. In the electron sea model, the positive metal ions can slide over one another without breaking the structure. This is possible because the electrons are not fixed; they continue to move and hold the ions together. So, even when layers of the metal ions shift, the metal does not break.

Similarly, you know that ductility refers to the ability of metals to be drawn into wires. When we stretch a metal, these metal ions slide past each other without breaking the non-directional metallic bonds, allowing the metal to stretch into wires. The free electrons help maintain the attraction between ions even when the shape changes.

You must remember that the electron sea model gives a simple picture and explains many basic properties of metals. The electrons are not completely lost as in ionic bonding; rather, they are shared collectively by all atoms in the metal. You will learn more detailed models of metallic bonding in your higher classes.

Check Your Understanding

1. What is meant by the term “electron sea” in metals?
2. What type of particles are in a fixed position in a metal according to the Electron sea model?
3. Define metallic bonding.
4. Why are metallic bonds called non-directional?

5. Name two properties of metals explained by the electron sea model.
6. Explain how the electron sea model accounts for electrical conductivity in metals.
7. How does the electron sea model explain thermal conductivity in metals?
8. Why can metals be beaten into thin sheets? Explain using the Electron sea model.
9. What is meant by ductility? How is it explained by the electron sea model?
10. How is metallic bonding different from covalent bonding?
11. Explain the structure of a metal according to the electron sea model.
12. If electrons in a metal were not free to move, which property would be most affected? Explain.
13. Explain why metals do not break when hammered but instead change shape.
14. Copper is used for electrical wiring, while rubber is not. Explain using the electron sea model.
15. Why are metals generally good conductors of heat as compared to non-metals?
19. Assertion (A): Metals are good conductors of electricity.
Reason (R): Metals contain free electrons that can move under an electric field.
 - A. Assertion and reason, both are correct and reason is the correct explanation of the assertion.
 - B. Assertion and reason, both are correct but reason is not the correct explanation of the assertion.
 - C. Assertion is correct but reason is a wrong statement.
 - D. Assertion is wrong but the reason is a correct statement.
20. Assertion (A): Metallic bonds are non-directional.
Reason (R): Electrons in metals are localised between two atoms.
 - A. Assertion and reason, both are correct and reason is the correct explanation of the assertion.
 - B. Assertion and reason, both are correct but reason is not the correct explanation of the assertion.
 - C. Assertion is correct but reason is a wrong statement.
 - D. Assertion is wrong but the reason is a correct statement.
21. Assertion (A): Metals are malleable.
Reason (R): Layers of metal ions can slide while electrons continue to hold them together.

- A. Assertion and reason, both are correct and reason is the correct explanation of the assertion.
- B. Assertion and reason, both are correct but reason is not the correct explanation of the assertion.
- C. Assertion is correct but reason is a wrong statement.
- D. Assertion is wrong but the reason is a correct statement.

Mixtures And Separation Of Mixtures

8.1 Chromatography

Chromatography was first developed by the **Russian botanist Mikhail Tswett in 1906** while studying plant pigments. He used this technique to separate the different coloured constituents of chlorophyll. This method was named **chromatography** components of chlorophyll. The name chromatography comes from the Greek words chroma (colour) and graphein (to write). The technique is used to **separate the mixtures into components, purification of compounds and also to test the purity of compounds.**

Principle: The technique is based on the difference in the rates at which the components move through a stationary medium under the influence of moving phase..

Application: Today, chromatography is widely used in chemistry, biology, and medicine to **identify and separate different substances in a mixture.**

Column Chromatography

Modern method for the separation of mixtures into its components. The selective removal of the components may be due to adsorption or partition process.

When a mobile phase is allowed to move over a stationary phase, the components of the mixture move by varying distances over the stationary phase because of different adsorption tendencies. In this case the stationary phase can be held on a cylindrical column of solid . hence it is called column chromatography.

Principle: It is based on the fact that different compounds are adsorbed on an adsorbent to different degrees

Procedure: In this technique, a long glass tube having a stop cock near the bottom, called a column is used. First a plug of cotton or glass wool is placed at the bottom of the column. Then it is filled with a solid material such as silica gel or alumina, which acts as the **stationary phase** (fixed in a place). The mixture to be separated is placed at the top of silica gel in the column, and then a little amount of glass wool is placed above the mixture. After this a suitable liquid solvent is poured from above and allowed to flow through the column under the influence of gravity. This is called an eluent or the **mobile phase** (which moves). The solvent coming out from the column is collected in different fractions. In this way, the components of the mixture get separated and are collected separately. Column chromatography is widely used in chemistry laboratories to purify compounds as well as to separate them from the mixtures.

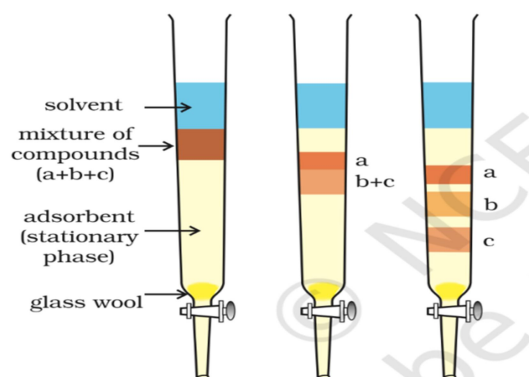

Fig 8.1: Column chromatography: Different stages of separation of components of a mixture.

Application: The method has been used:

- To separate blue and red dyes
- To separate and purify plant pigments

8.2.1 Fractional Distillation

This method is used for the purification of liquids which boil without decomposition and contain non volatile impurities.

Principle: Fractional Distillation is a technique to separate a mixture of two miscible liquids whose boiling points differ by less than 25⁰C shown in Fig. 8.2 (a).

In this process, the mixture of liquids is heated in a distillation flask which is fitted with a fractionating column before the condenser as shown in figure 8.2(b).

Fractionating Column: The fractionating column is a long tube provided with obstructions to the passage of vapours moving upwards and liquid moving downwards. It increases the cooling surface area.

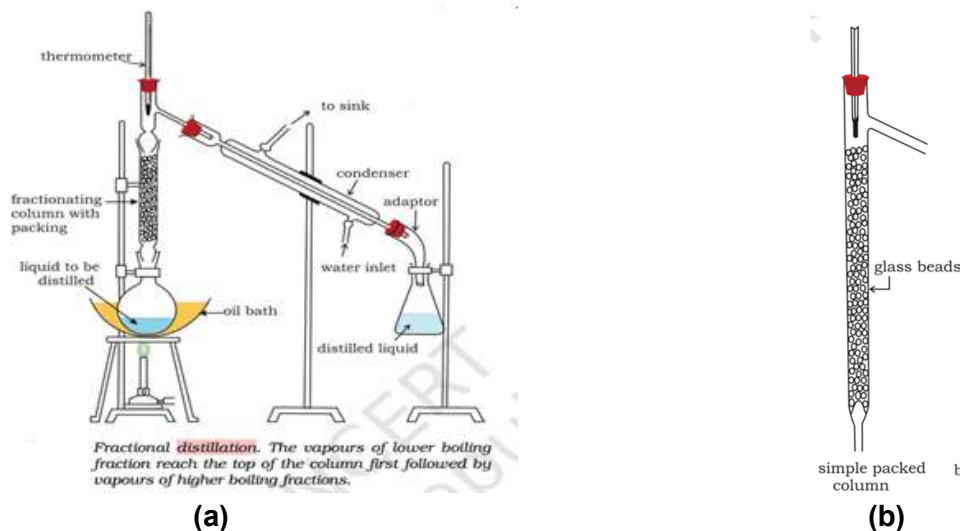

Fig 8.2: (a) Fractional distillation apparatus and (b) A sample fractional distillation column

Procedure: When the mixture is added to distillation flask and the flask is heated the vapours of more volatile liquid having low boiling point rises up in the fractionating column. Due to the obstruction in the fractionating column, some of the vapours condense and fall back in the column. Some of the condensing liquid in the fractionating column gets heat from the ascending vapours and re-vaporizes. As a result the vapours become richer in low boiling component. These rise up in the fractionating column and condense while passing through condenser and collected in the receiver. The same process will occur again and again. This repeated condensation and vaporization helps in better separation of the liquids. By carefully controlling the temperature, different liquids in the mixture can be separated one after another according to their increasing boiling points.

8.2.2 How is it different from simple distillation?

- In fractional distillation, a fractionating column is placed between the distillation flask and the condenser. The column provides many surfaces where repeated condensation and vaporization occur. This allows better separation of liquids whose boiling points are close to each other.
- Simple Distillation is used to separate miscible liquid which differ in boiling point by at least 25°C but in fractional distillation the boiling point differ by less than 25°C

8.2.3 Application

Crude oil is a complex mixture of many hydrocarbons with different boiling points. In a refinery, the crude oil is heated, and the vapours enter a tall fractionating column. As the vapours rise in the column, they cool and condense at different levels according to their boiling points. Different fractions are collected at different heights of the column as shown in the figure below along with the temperature range. The various important fractions used in our daily life or industry are:

- Petroleum gas (LPG, contains butane and propane)
- Petrol (gasoline)
- Kerosene
- Diesel
- Fuel oils
- Lubricating oil and heavy oils

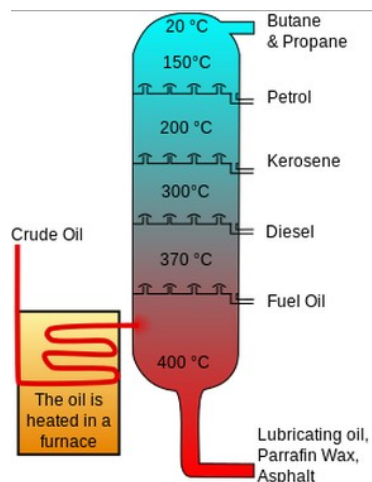

Fig 3: (a) Schematic representation of separation of different components of crude oil by fractional distillation

Questions

1. What is chromatography? Mention its two main phases.
2. Who discovered chromatography and in which year?
3. What is meant by stationary phase and mobile phase?
4. Name two common adsorbents used in column chromatography.
5. What is an eluent in column chromatography?
6. Why do different substances move at different speeds in column chromatography?
7. What is fractional distillation?
8. When is fractional distillation preferred over simple distillation?
9. What is the role of the fractionating column?
10. In column chromatography, a mixture of two compounds A and B is separated. A comes out first. What can you say about its interaction with the stationary phase?
11. A mixture of ethanol (b.p. 78°C) and water (b.p. 100°C) is to be separated. Which method will you use and why?
12. Explain why repeated condensation and vaporization improve separation in fractional distillation.
13. In a fractional distillation column, why does temperature decrease from bottom to top?
14. Why is simple distillation not suitable for separating liquids with close boiling points?
15. Assertion: In chromatography, separation occurs due to difference in boiling points.
Reason: Components move at different speeds in the column.
A. Assertion and reason, both are correct and reason is the correct explanation of the assertion.

- B. Assertion and reason, both are correct but reason is not the correct explanation of the assertion.
 - C. Assertion is correct but reason is a wrong statement.
 - D. Assertion is wrong but the reason is a correct statement.
16. Assertion: Fractional distillation gives better separation than simple distillation.
Reason: It involves repeated condensation and vaporization.
- A. Assertion and reason, both are correct and reason is the correct explanation of the assertion.
 - B. Assertion and reason, both are correct, but reason is not the correct explanation of the assertion.
 - C. Assertion is correct, but reason is a wrong statement.
 - D. Assertion is wrong, but the reason is a correct statement.
17. Difference in which property forms the basis for separating components in fractional distillation?
- A. Solubility
 - B. Boiling points
 - C. Particle size
 - D. Chemical reactivity
18. What is the main purpose of the "fractionating column" in fractional distillation?
- A. To heat the mixture faster.
 - B. To cool the vapours at fast rate.
 - C. To provide more surface area for vapours.
 - D. To let the vapours of two liquids mix properly
19. In column chromatography, the solid substance that is filled in the column is called the:
- A. Mobile phase
 - B. Solvent
 - C. Stationary phase
 - D. Mixture
20. That component of a mixture moves down the column at a faster rate which is
- A. most attracted to the stationary phase.
 - B. having the highest boiling point.
 - C. The one most soluble in the mobile phase (solvent)
 - D. The one with the largest particle

Microscope and Microscopy

9.1. What is a Microscope?

You have read in Grade 8 that a special instrument called the **microscope** (*micro* – small; + *skopion* - "means of viewing") is required to observe tiny living organisms or their parts which cannot be seen through naked eyes by magnifying them. With a microscope, you can see small specimens such as onion cells, cheek cells, bacteria and even dust particles etc. It helps doctors to see germs and study cells in living organisms.

What do we call the ability of a human eye to see two very close objects as separate and distinct? Imagine two tiny dots drawn on a piece of paper. As the dots are moved closer, there comes a point at which they can no longer appear as separate. When viewed from about 25 cm (the near point of the eye), two points separated by about 0.1 mm (100 μ m) can be observed as distinct, otherwise, they appear as a single point. This defines the **limit of resolution** of the human eye.

A cell is generally too tiny to be observed by an unaided eye. This raises an important question - how do cell biologists study the structure and functioning of cells, which are much smaller than the limit of resolution of the human eye?

When Robert Hooke observed 'cork' under the microscope developed by him in 1665. He examined thin slices of bark of an oak tree and observed tiny hexagonal box-like spaces just like the patterns of honeycomb and called them **cells**. Around the same time, Antony van Leeuwenhoek made tiny, powerful lenses and saw "animalcules" – what we now know as bacteria and protozoa. Those simple lenses opened the door to a completely new world.

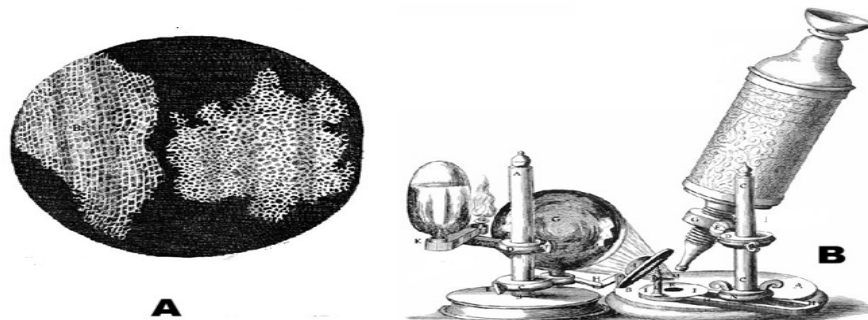

Figure 9.1: A. Drawings of Cork cells as published in the 'Micrographia'; B. Microscope developed by Robert Hooke,

Activity 9.1: Let us think and write:

If you could shrink yourself and travel inside a leaf, what would you see? Write 3 – 4 lines imagining that journey.

9.2. A Quick historical Journey of Microscopes

Let us walk through time and see how microscopes evolved:

- **13th–15th century:** Simple magnifying glasses used by spectacle makers.
- **1590 - Hans and Zacharias Janssen:** A Dutch father-and-son duo of spectacle makers developed an early compound microscope by combining two lenses within a single tube.
- **1665 – Robert Hooke:** Coined the term ‘cell’ for empty, hexagonal, box-like structures by examining the cork of an oak tree under the microscope developed by him. He published his findings in a book called “Micrographia”.
- **1670s – Antony van Leeuwenhoek:** He worked with a simple, single-lens microscope capable of magnifying up to about 300 times, which allowed him to observe tiny living organisms he called “animalcules,” including bacteria and protozoa. He was the first to study living microorganisms and is widely regarded as the *Father of Microscopy*.
- **1878 Ernst Abbe:** Postulated a mathematical theory linking resolution to the wavelength.
- **19th–20th century:** Better lenses and illumination improved the compound light microscope.
- **1930s onwards: Electron microscopes** (TEM and SEM) were invented where viruses, cell organelles and cell surfaces could be observed.
- **1938 Ernst Ruska:** developed the first electron microscope, which operated on the principle using electrons as the illumination source (instead of light) that provides shorter wavelengths and thereby significantly enhancing the resolving power.
- **1953: Frits Zernike** received the Nobel Prize in Physics for inventing and demonstrating the phase-contrast microscope.

Activity 9.2: A Timeline Strip

Draw a horizontal line. Mark at least 5 important dates in microscopy and add a tiny sketch or symbol for each (e.g., cork cells, bacteria, electron beam etc.).

9.3. How Does a Microscope Work?

An important parameter in microscopy is the **resolution**, **contrast** and **magnification** of the object that is viewed under the lens, which makes it appear several times larger to the human eye. The operating principle varies with the type of microscope, which can be broadly classified by whether they use multiple lenses or electron beams. In each case, a system of lenses or electromagnetic fields is used to produce an enlarged, detailed image of a specimen that cannot be clearly seen with the naked eye.

9.3.1 Types of Light microscope

Light (Optical) microscopes rely on visible light and glass lenses to enlarge and view specimens.

Basic Classification -

- **A simple microscope** utilizes a single lens to magnify an object, similar to how a magnifying glass works. For example, dissecting microscope is used for 3D viewing of small objects.
- **Compound Microscope:** Most commonly used laboratory microscope utilizes at least two sets of lenses - the objective lens (near the specimen) and the eyepiece (ocular lens) - to achieve high magnification.
- **Advanced optical microscopes**

Beyond the standard compound microscope, a diverse family of advanced light microscopes exists—such as Phase-Contrast and Fluorescence, each using unique optical technique to reveal hidden cellular secrets that would otherwise remain invisible to the naked eyes. **Fluorescence microscopy** uses high-intensity light to excite specialized dyes in a specimen, causing specific cellular structures to glow brilliantly against a dark background like stars in the night sky. **Phase-Contrast** microscopy is used for viewing **living cells** in their natural state because it enhances contrast without the need for chemical stains that would otherwise kill the specimen.

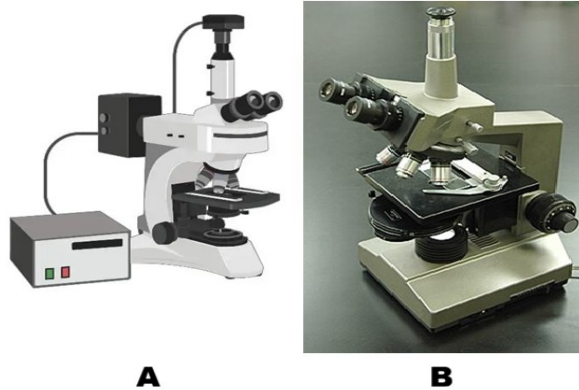

Figure 9.2: A. Fluorescence microscope; B. Phase contrast microscope

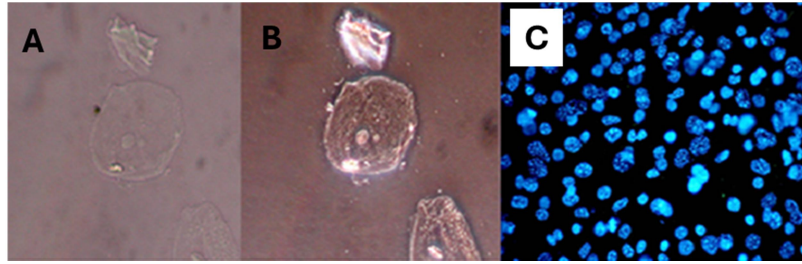

Figure 9.3: Cells imaged with – A. Traditional optical microscope (Mag. 40X) B. Phase-contrast microscope (Mag. 40X) and C. Fluorescence microscope (Mag. 20X)

9.3.2 Parts of a Compound microscope

Core Components and their Roles

1. **Light Source**; Provides illumination (LED or halogen lamp).
2. **Condenser Lens**: Focuses light onto the specimen to optimize numerical aperture and contrast.
3. **Specimen Stage**: Holds the slide containing the specimen.
4. **Objective Lens**: The primary magnifying lens (e.g., 4X, 10X, 40X, 100X). It forms an enlarged, inverted image of the specimen that is real in nature.
5. **Eyepiece (Ocular Lens)**: It enhances the magnification of the image already produced by the objective lens.

Activity 9.3: Let us examine a compound microscope

Key parts include eyepiece, objectives, nosepiece, stage with clips, coarse/ fine focus, condenser, iris diaphragm, illuminator, arm, and base

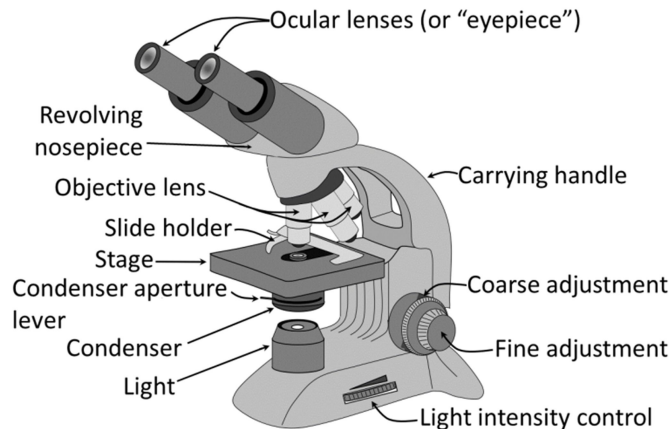

Figure 9.4: Light (compound) microscope

- **Objective lenses**: Main magnifying lenses (with different magnification power (X) – 4, 10, 15, 20, 40 etc.) close to the slide. These form a real, magnified image of the object.

- **Eyepiece (ocular lens):** Where you place your eye. It acts like a magnifying glass for the image formed by the objective. Together, these lenses produce a greatly enlarged image for your eye.
- **Body tube:** A hollow tube which has the eye piece and objective fitted on its two ends.
- **Revolving nosepiece:** Holds objectives and allows you to switch between them.
- **Stage and clips/ mechanical stage:** Platform to hold the slide in place.
- **Condenser Lens:** Consists of convex lens to focus and concentrate the light on specimen to optimize numerical aperture and contrast.
- **Substage diaphragm:** Controls the amount of light transmitted on specimen
- **Coarse adjustment knob:** Big knob for rough focusing (low power).
- **Fine adjustment knob:** Small knob for sharp focus (high power).
- **Arm and base:** Support; always hold microscope by the arm and support the base.
- **Light source/ mirror:** Provides light that passes through specimen/reflects light.

9.3.3 Light Microscope – working

Light changes direction when it passes through glass. You have earlier learnt in Grade 8 that a **convex lens** (converging lens) bends light rays to meet at a point. When we place a tiny object near such a lens, the lens forms a larger, inverted image. Light microscopes function by using refraction—the bending of light as it moves between different media due to changes in speed—along with reflection to direct and focus light rays. The objective lens, which has a short focal length, first creates a real and inverted image of the specimen placed just outside its focal point. This image then becomes the input for the eyepiece, which has a longer focal length and further enlarges it, producing the final upright, highly magnified virtual image.

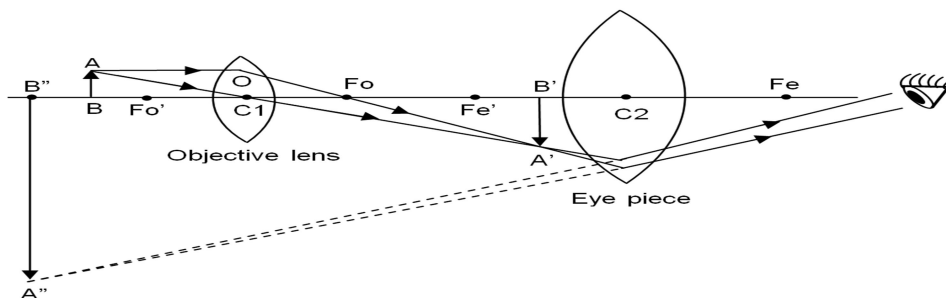

Figure 9.5: Ray diagram of compound microscope

9.4. Microscopy Skills

9.4.1 Slide Preparation and Focusing (temporary mount)

You have already learnt the method for preparing a temporary mount of an onion peel; using a similar approach, let us now create a few more temporary mounts.

Activity 9.4: Let us prepare, observe and compare leaf peels of monocot and dicot leaves:

Take peels from both upper and lower epidermis of a monocot leaf (*Rhoeo/ maize/ lily*) and a dicot leaf (*Bryophyllum/ petunia/ balsam*). Prepare their temporary mounts. Observe them under microscope, compare their structure and draw labelled diagrams. Record similarities and differences, if any.

Now correlate the points noted by you in activity 9.1 with your observations.

| S. No. | Feature | Monocot leaf | | Dicot leaf | |
|--------|----------------------------|---------------------------|--|---------------------------|--|
| | | Name of source plant..... | | Name of source plant..... | |
| 1. | Shape of epidermal cells | | | | |
| 2. | Pattern of epidermal cells | | | | |
| 3. | Shape of Guard cells | | | | |
| 4. | Distribution of stomata | | | | |
| 5. | Any other observation | | | | |

9.4.2 Permanent Slides

We have already learnt how to prepare temporary mounts. These are useful only for a short time because the drop of water slowly dries up and the living cells start shrinking, and dying. If you leave a temporary mount of an onion peel for a few hours, you will notice air bubbles, crystals of the dried stain, and distorted cell shapes instead of fresh, clear cells.

Now think, what if we want to keep a well prepared slide of onion cells or cheek cells safe so that many future batches of students in your school can observe it? For this purpose, biologists make **permanent mounts**. The slides stored carefully in slide boxes in your laboratory are usually permanent slides that have been prepared using a special technique and preserved for years.

In a **permanent mount**, the specimen is first fixed (to kill and preserve its structure), then stained, dehydrated, and finally sealed in a special mounting medium such as Canada balsam or DPX under a coverslip. This prevents the

specimen from drying, rotting, or being attacked by microorganisms. Once prepared properly, a permanent slide can be stored in the laboratory and used repeatedly without losing clarity of cells when seen under the microscope.

Activity 9.5: Let us observe permanent slides of leaf peel of a monocot and dicot leaf

Observe a permanent slide of leaf peel of monocot and dicot leaf and compare it with the temporary mount prepared by you.

Do you find any difference in the clarity of the slides? Notice the cell walls and guard cells in the fresh temporary mount and the stained permanent mount of the dicot peel? Does the clarity of cell walls and guard cell differ? Identify two common anatomical differences in leaf peels that remain consistent in temporary and permanent mount.

9.4.3 By what factor is the image larger than the actual object?

When you look at a diagram of a cell or a tiny insect in your book, it often appears huge on the page, now you know that it might be smaller than a grain of sand. Further, when you observed onion peel cells under the microscope you would have noticed the difference in the size of image when we switch from low power to high power objective lens.

How do you know *exactly* how many times bigger you are seeing the image? We can find out by finding the magnification of objective and eye piece. Magnification is represented by the symbol X, which is read as “times,” for example, 10X means “magnified ten times.”

Magnification of a microscope: $M = m_o \times m_e$
Where m_o = magnification of objective, m_e = magnification of eyepiece.

Example:

- 10X eyepiece and 40x objective $\rightarrow M = 10 \times 40 = 400$.
- Real size = image size / total magnification

Let us find out:

1. If a cell measures 5 mm on 100X image, calculate its actual size.
2. If you use a 15X eyepiece and 10X objective, what will be the total magnification?
3. If 4 cells fit across a 0.8 mm field of view, what will be the approximate size of one cell?

9.5. Types of Microscopes

All microscopes do the same basic function – they magnify small objects – but they do it in different ways and to different depths. Magnification and resolution are core concepts in microscopy that define the imaging capabilities of a microscope. Different microscopes have different magnification powers and resolution ranges; the size of the specimen and purpose of observation determines which microscope can be used to view the specimen effectively.

9.5.1 Magnification vs. Resolution – Big vs. Sharp image

Generally, students think: “More magnification is always better.” Not always true!

- **Magnification:** Magnification is the factor by which a microscope enlarges the image of a specimen relative to its actual size (e.g., 400x).
- **Resolution:** Resolution is the smallest distance between two very close points in a specimen to clearly distinguish them as separate and not merged into a single image. It is often expressed as a unit of length e.g. 0.2 μm for light microscopes. Higher resolution reveals fine details and gives a sharp image. **Resolving power** is the capacity of the microscope to clearly identify two very closely placed points as separate points. It is expressed as the reciprocal of resolution (smaller resolution means higher resolving power).

The **resolution** of human eye and some microscopes is given below:

| Instrument | Resolution (in metre) |
|---------------------|---|
| Human eye | $\sim 1 \times 10^{-4} \text{ m}$ ($\approx 0.1 \text{ mm}$) |
| Light microscope | $\sim 2 \times 10^{-7} \text{ m}$ ($\approx 0.2 \mu\text{m}$) |
| Electron microscope | $\sim 2 \times 10^{-10} \text{ m}$ ($\approx 0.2 \text{ nm}$) |

Let's know more about the units of length used in microscopy:
1 cm = 10 mm
1 mm = 1,000 μm (micrometres)
1 μm = 1,000 nm (nanometres)

9.5.2 Light (Compound) Microscope

This is the microscope you generally use in school laboratories.

- It uses **visible light** and **glass lenses**.
- Its magnification is usually up to about 1000x.
- Its resolution (smallest detail you can see clearly) is about 0.2 μm .
- It can be used to observe living cells, like moving protozoa or cheek cells.

9.5.3. Electron Microscopes

- Electron microscopes operate with electron beams that have extremely short wavelengths (about 0.005 nm compared to 550 nm for visible light). These electrons are accelerated in a vacuum and directed using magnetic lenses.
- Electrons also behave like waves, but with a **much shorter wavelength** than visible light. A shorter wavelength gives better resolution.
- Electromagnets act as “lenses” to focus on the electron beam.
- Source of electron beam (Tungsten filament).

9.5.3.1 Transmission Electron Microscope (TEM)

It is much more powerful as compared to the light microscope because it has better magnification and resolution.

- It operates with a beam of **electrons** rather than light.
- Extremely thin slices of the specimen, about 50–90 nm thick, are prepared using an ultramicrotome equipped with a glass knife.
- Electrons pass through an ultra-thin slice of specimen.
- Heavy metal stains like uranyl acetate (for proteins/ nucleic acids) and lead citrate (for lipids/ carbohydrates) are used. These increase electron density *via* positive staining, providing contrast without dissolving in embedding resins.
- Internal details of cells – mitochondria, ribosomes, viruses etc. can be observed.
- Image produced is two – dimensional (2D).
- Resolution can be around 0.1 nm.

9.5.3.2 Scanning Electron Microscope (SEM)

- It operates with a beam of **electrons** rather than light.
- Unlike TEM's ultrathin sections (50-90 nm) cut by glass knives, SEM uses diamond knives for thicker sections or whole mounts.
- Heavy metal coatings provide conductivity for electrons.
- Electrons are reflected from the specimen.
- Electrons scan the surface of the specimen.
- Gives 3D-like images of surfaces – pollen grains, insect legs, microchips.
- Resolution can be around 1 – 20 nm.



Figure 9.6: A. Transmission Electron Microscope B. Scanning Electron Microscope

(Source: Wikimedia commons)

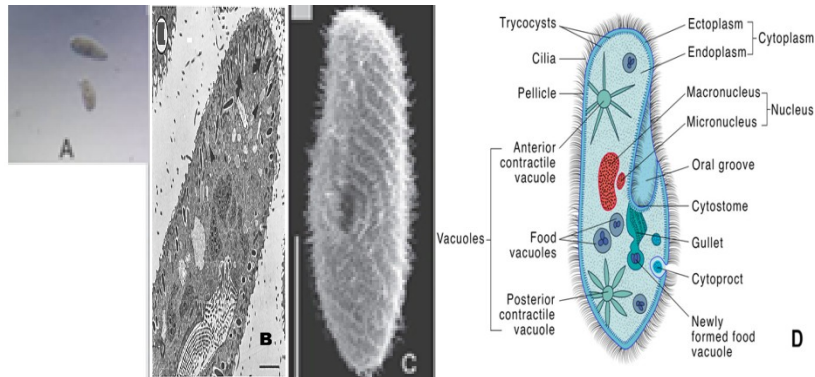

Figure 9.7: *Paramecium* as observed under - A. Light Microscope (Wikimedia commons); B. Transmission electron microscope (Source: Research Gate); C. Scanning electron microscope (Source: Research Gate) and D. Diagrammatic representation.

9.5.3.3 Let us compare Light microscope and Electron microscope (TEM and SEM)

The comparison between these three types of microscopes can be summarised as below:

| S. No. | Feature | Light Microscope | Transmission Electron Microscope | Scanning Electron Microscope |
|--------|------------------------|---|---|--|
| 1. | Illumination source | Visible light | Electron beam (broad) | Electron beam (focused, scanned) |
| 2. | Types of lenses | Glass (convex, achromatic) | Electromagnetic coils (condenser, objective, projector) | Electromagnetic coils (condenser, scanning, objective) |
| 3. | Thickness of section | Up to several mm - whole mounts; 5 - 10 μm for tissue sections | Ultra-thin (<100 nm, typically 50-90 nm ultramicrotomy) | Surface only (no sectioning; samples 20 - 30 mm thick, coating 10 -100 nm) |
| 4. | Staining | Basic dyes (e.g., methylene blue, eosin; light-absorbing) | Dense metal compounds, such as uranyl acetate and lead citrate. | Conductive coating (e.g., gold/ palladium; no traditional staining) |
| 5. | Observing living cells | Yes (e.g., pond life, cheek cells) | No (vacuum kills cells) | No (vacuum and the coating kills cells) |
| 6. | Resolution | $\sim 0.2 \mu\text{m}$ | $\sim 0.1 \text{ nm}$ or better | $\sim 1-10 \text{ nm}$ |
| 7. | Magnification | Up to 1,500x | Up to 50 million x | Up to 2 million x |
| 8. | Sample | Minutes | Hours-days | Hours (dehydration, |

| | preparation time | (simple mounting) | (embedding, ultramicrotomy) | coating) |
|-----|------------------|-----------------------|-----------------------------|--------------------|
| 9. | Cost | Low (~₹10,000-50,000) | Very high (₹50 lakh+) | High (₹20-50 lakh) |
| 10. | Vacuum required | No | Yes | Yes |

Think

Why do you think electron microscopes are usually found in big research centres and not in normal school laboratories?

9.6. What is new in Microscopy? What are the limits?

9.6.1 New Developments

With advances in science and technology, digital microscopes are being developed that show a real time image directly on a screen. Thus, live images can be shared with all students at once. In Super-resolution microscopes details smaller than the normal limits of light can be observed. Explore these latest inventions through books, trusted websites, science magazines, and virtual lab simulations, and find out what new things could we discover by using an even better microscope! Your curiosity today may help design the microscopes of tomorrow.

9.6.2 Limitations

- With a light microscope, structures smaller than about 0.2 μm cannot be resolved due to the diffraction limit of light.
- Electron microscopes are costly, need vacuum and very careful sample preparation; most samples have to be processed with chemicals and metal stains.

9.7. Where do we use Microscopes?

You might be surprised how often microscopes quietly support our lives.

- **Hospitals and Pathology laboratories:** Diagnosing diseases by checking blood, sputum, tissue biopsies (e.g., malaria parasites in blood).
- **Science laboratories:** Studying stomata, plant and animal tissues, plant diseases etc.
- **Industry:** Checking quality of metals, plastics, electronic chips using light and electron microscopes.
- **Police and forensics:** Examining fibres, hair, glass fragments, blood stains from crime scenes.
- **Environment:** Checking water samples for algae, protozoa and pollution indicators.

Snapshots

- Microscope (*micro* – small; + *skopion* - "means of viewing") is a special instrument required to observe tiny living organisms or their parts which cannot be seen through naked eyes.
- Different microscopes have varied magnification powers and resolution ranges; the size of the specimen and purpose of observation determines which microscope can be used to view the specimen effectively.
- Magnification is the factor by which a microscope enlarges a specimen's image relative to its actual size (e.g., 400 X).
- Resolution is the smallest distance between two very close points in a specimen to clearly distinguish them as separate and not merged into a single image. It is often expressed as a unit of length e.g. 0.2 μm for light microscopes.
- Light (Optical) microscopes rely on visible light and glass lenses to enlarge and view specimens.
- Light microscopes function by using refraction—the bending of light as it moves between different media due to changes in speed—along with reflection to direct and focus light rays.
- They can be broadly grouped according to the number of lenses used: simple microscopes have a single lens, while compound microscopes contain two or more lenses.
- Fluorescence microscopy uses high-intensity light to excite specialized dyes in a specimen, causing specific cellular structures to glow brilliantly against a dark background like stars in the night sky.
- Phase-contrast microscopy is a premier technique for observing living cells in their native state because it enhances contrast without requiring chemical stains that would compromise cell viability.
- For light microscopy, we can prepare temporary or permanent mount depending upon the short term or long-term storage requirement.
- Electron microscopes use electron beams (shorter wavelength ~ 0.005 nm vs. light 550 nm) accelerated in vacuum, focused by magnetic lenses.
- Electron microscopes are classified as transmission (TEM) or scanning (SEM) based on how the electron beam interacts with the specimen—either passing through it or being reflected from its surface.
- TEM shows internal details of cells in 2D – mitochondria, ribosomes, viruses etc while SEM gives 3D-like images of surfaces.
- In addition to the study of cell and its organelles, microscopes are used for diagnosing diseases, for assessing the quality of metals, plastics, electronic chips, analysis of water samples and in forensics etc.

Check Your Understanding

1. A microscope has a 10X eyepiece and a 40X objective.
 - a) What is its total magnification?
 - b) At this setting, the field of view is 0.4 mm. If 4 cells fit across, estimate the size of one cell.
2.
 - a) You want to watch live protozoa moving in pond water. Which microscope (light, phase-contrast, TEM, SEM) is best and why?
 - b) Neha wants to study the 3D surface of a pollen grain. Which microscope should she choose and why?
3. Riya sees a sharp onion cell image at 100X, but when she switches to 400X, the image is big but very blurred. Name the concept causing this problem. Explain the reason.
4. Draw a ray diagram of a compound microscope.
5. Design a simple poster "How to take care of a microscope?" with three do's and three don'ts.
6. At 40X total magnification, the field diameter is 4 mm. Predict the field diameter at 400X magnification (assume it is inversely proportional to magnification).
7. A student accidentally traps many air bubbles while placing the cover slip. How will this affect observation? Suggest two ways to avoid bubbles next time.
8. Compare TEM and SEM in terms of:
 - Type of image.
 - Best use (internal vs surface).
9. Plan a brief investigation using a school light microscope to compare the purity of three water samples (tap water, RO-purified water, and pond water). Outline the main steps and predict your expected observations.
10. Can we rely on electron microscopes for studying living cells? Explain the reason.
11. List two ways how microscopes are used in hospitals and one way they are used in industries that manufacture mobile phones.
12. Imagine you are Robert Hooke. Write a 5–6 lines diary entry about what you felt when you first saw "little boxes" (cells) in cork.
13. Ananya says, "If we add more and more lenses, we can see anything, even atoms, with a school microscope." Use the idea of resolution to correct this statement.

14. Nishant wants to observe the effect of concentrated salt solution on cells of *Rhoeo* leaf and also wants to keep slides for future reference. Answer the following:
- Which type of mount should be used for this purpose? Give reason.
 - Will the same slide be suitable for long-term storage? Elucidate the reason.
15. Why is it important to fix and dehydrate cheek cells before mounting in Canada Balsam for school laboratory storage? Predict the consequences if a student inadvertently skipped the fixation and dehydration steps before mounting the specimen in Canada Balsam.

References:

- Cell and Molecular Biology: P.K. Gupta
- Laboratory Manual of Cell Biology: Rina Majumdar and Rama Sisodia
- Microbiology – An introduction: Gerrard J. Tortora, Berdell R. Funke and Christine L. Case
- <https://ucmp.berkeley.edu/history/hooke.html#:~:text=Hooke%20had%20discovered%20plant%20cells,the%20cells%20of%20a%20monastery.>
- <https://www.microscope.com/education-center/microscopes-101/compound-microscope-parts>
- <https://pmc.ncbi.nlm.nih.gov/articles/PMC6111892/>
- <https://www.fizzicseducation.com.au/articles/digital-microscopy-teaching-students-biology-their-way/>
- <https://www.microscope.com/education-center/articles/history-of-microscopes>
- [https://bio.libretexts.org/Bookshelves/Microbiology/Microbiology_\(Boundless\)/03:_Microscopy/3.01:_Looking_at_Microbes/3.1D:_Magnification_and_Resolution](https://bio.libretexts.org/Bookshelves/Microbiology/Microbiology_(Boundless)/03:_Microscopy/3.01:_Looking_at_Microbes/3.1D:_Magnification_and_Resolution)
- <https://www.jeolusa.com/RESOURCES/Electron-Optics/Documents-Downloads/sample-preparation-techniques-conductive-coatings1>
- <https://www.leica-microsystems.com/science-lab/life-science/brief-introduction-to-coating-technology-for-electron-microscopy/>
- <https://www.ntnu.edu/documents/139994/141053151/TEM+sample+preparation.pdf/eb6c557f-8243-4923-9135-cc8f8fa5c37f>
- https://www.researchgate.net/figure/TFP-treatment-followed-by-Ca-2-ionophore-A23187-TFP-exposure-was-carried-out-at-the_fig5_16791858
- https://www.researchgate.net/figure/Scanning-electron-micrographs-of-normal-a-and-deciliated-b-paramecia-Note-that-the_fig5_15839897

Engineering Life: Miracles in Biotechnology

10.1 Introduction to Biotechnology

For centuries, humans have relied on living organisms and their properties to improve the quality of life. Whether it is using bacteria to turn milk into curd, using yeast to make the bread we eat, or making the homemade probiotic drink, kanji. By influencing and modifying living organisms through innovation, humans have become engineers of life.



Figure 10.1: Miracles with Biotechnology

Biotechnology refers to the judicious use of living organisms, such as microbes, or their cellular components, to produce substances beneficial to humans. In the modern era, biotechnology has evolved from simple kitchen chemistry to sophisticated genetic engineering.

Human beings have been using biotechnology for a long time. Selective breeding and using the fermentation process for the production of cheese, beer and wine have been practiced since centuries. Today, microbes are not only used to make traditional fermented foods but are also widely exploited in industrial biotechnology for the production of valuable substances such as antibiotics, enzymes, improving the nutritional quality of food items, biofuels and the production of eco – friendly products.

As early as 1973, scientists observed that the genes from microbes can be taken out from one organism and can be inserted in different organism to get a desired altered gene. This branch of biotechnology is called **genetic modification/ genetic engineering/ recombinant DNA (rDNA) technology**, wherein the gene is modified to enhance the production of enzymes, antibiotics, vitamins, hormones (such as insulin), and other industrially significant substances. Thus, Biotechnology has led to advancements in many fields such as medicine, agriculture, animal science and environmental science.

Some common areas where Biotechnology has led to advancements are:

| Category | Areas covered |
|---------------------|--|
| Blue Biotechnology | Application of biotechnology for marine and freshwater organisms, which are used for increasing the seafood supply, regulation of water – borne diseases and developing new drugs. |
| Green Biotechnology | Improvement in the nutritional quality, quantity and production of eco – friendly products. Development of transgenic plants for better productivity and disease resistance. |
| Red Biotechnology | Medical Biotechnology, which is applied to manufacture pharmaceutical products such as insulin, enzymes, antibiotics, and vaccines |

(Source: Biotechnology: textbook for class XI, NCERT Publication)

Activity 10.1: Observe Fermentation at Home

Aim: To understand microbial action in food.

Materials Required: Warm milk, a spoon of curd, one bowl

Procedure:

1. Pour warm milk into a bowl.
2. Add a spoonful of curd into it.
3. Leave it overnight in a warm place.

Observation: Milk turns into curd.

Conclusion: Microorganisms present in curd convert milk into curd.

Discuss with your parents. In what times or situations does curd take a long time to form? What conditions support the curdling of milk?

Quick Check

1. What is biotechnology?
2. Give two examples from your daily life demonstrating the use of biotechnology.
3. Why are microorganisms important in biotechnology?

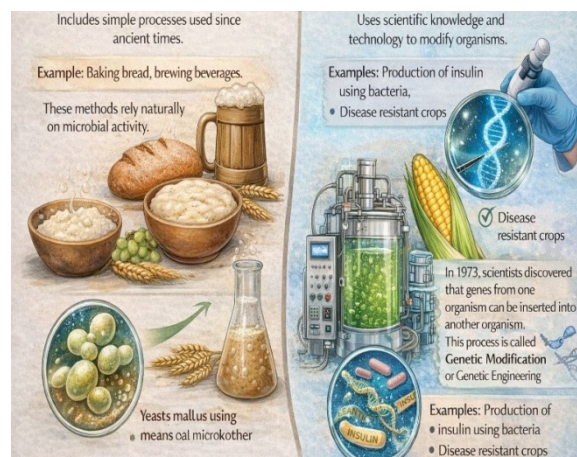

Figure 10.2: Biotechnology: Traditional vs Modern

10.2 Traditional vs Modern Biotechnology

Traditional biotechnology includes simple processes used since ancient times.

Example- Making wine, baking bread, brewing beverages. These methods rely on natural microbial activity.

Modern biotechnology uses scientific knowledge and technology to modify organisms. The process of transfer of genes from one organism to another involves a set of molecular techniques that allow scientists to deliberately modify the genetic material of an organism. Herein, specific genes can be “cut” from one organism and “inserted/ pasted” into another.

Examples: Production of insulin using bacteria, disease-resistant crops

Let us research

Activity 10.2: Traditional Biotechnology around you

- **Part A: Research on Fermented Foods:** Make a list of fermented foods used in your home or community. Identify the microorganism that may be responsible for it?
- **Part B: Preparing Probiotic Kanji**

Prepare **kanji**, a traditional fermented drink using **carrot and beetroot**.

- Place chopped carrot and beetroot pieces in a clean glass jar. Add water, salt, and a little mustard powder.
- Keep the jar in sunlight for **2–3 days**, stirring once daily.
- Observe the changes in **aroma, colour, and formation of bubbles**, which indicate microbial activity during fermentation.

Observation: Record your observations and results in the following table.

| Day | Changes in Color | Changes in aroma | Presence of Bubbles/Froth | Possible Microbial Activity |
|-------|------------------|------------------|---------------------------|-----------------------------|
| Day 1 | | | | |
| Day 2 | | | | |
| Day 3 | | | | |
| Day 4 | | | | |
| Day 5 | | | | |
| Day 6 | | | | |
| Day 7 | | | | |

Conclusion:

Quick Check

| Traditional Biotechnology | Modern Biotechnology |
|----------------------------------|---|
| Uses natural microbial processes | Uses _____ techniques |
| Used since _____ times | Developed in _____ times |
| Example: Making curd and bread | Example: Production of _____ using bacteria |
| Has limited control over _____ | Provides greater control over _____ |
| Does not involve gene transfer | Involves _____ modification |

10.3 Microbes as Tools in Biotechnology

Microorganisms such as bacteria, yeast and fungi are widely used in biotechnology. Why is the reason for this?

- Microbes are easy to grow. Bacteria can double their population in 20 minutes.
- They need basic nutrients (sugar, nitrogen) for their growth.
- They do not need much space, as millions of bacteria can be grown in a small space.
- Their DNA can easily be manipulated.
- Their DNA is self-replicating.

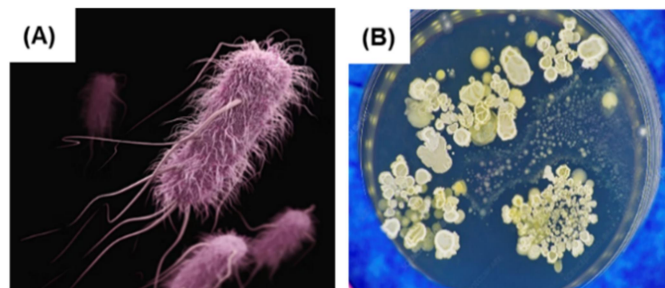

Figure 10.3: (A) Bacteria (B) Fungus

Let us observe

Activity 10.3: Fermentation at home

Mix 2 teaspoons of sugar in a bowl of warm water and add 1 teaspoon of dry yeast.

Cover it and wait for 15 minutes.

Observation: You will observe frothing and a pungent odour emerging.

Discussion: The froth is CO₂, and the smell is due to ethanol.

The yeast is "working" by breaking down sugar.

10.4 Applications of Biotechnology in Daily Life

A casual survey of everyday products reveals that biotechnology plays a key role in many of them. These innovations span diverse fields, transforming how we produce food, medicine, and more.

The following are the key areas involving the use of biotechnology.

1. Crop production and agriculture
2. Medicine and Health Care
3. Food processing
4. Bio-Enzymes: Revolutionizing Household Cleaning
5. Environmental protection

10.4.1 Crop production and agriculture

Genetic engineering of crop plants has enhanced traits like stress tolerance, insect resistance, viral resistance, productivity and nutritional value.

A gene is a segment of DNA that codes for specific proteins. Biotechnology now enables us to manipulate genes of interest to create recombinant DNA, producing genetically modified plants resistant to insect pests—like Bt cotton and Bt corn. Let's explore these examples further.

10.4.1.1 Pest-resistant crops

Bt toxin, a protein from the soil bacterium *Bacillus thuringiensis*, exhibits insecticidal properties. It targets larvae of moths, butterflies, and cotton bollworms but remains harmless to humans. The gene encoding this toxin is transferred to cotton, corn, potato, and tomato plants, creating transgenic varieties. These plants express the Bt toxin, which functions as a natural insecticide, protecting them from insect pests.



Figure 7: Genetically modified plant
e.g.: Bt cotton

These plants are engineered to be "self-protecting" against pests.

- **Source:** A soil bacterium called *Bacillus thuringiensis* (Bt) naturally produces a protein that is toxic for certain insects (like bollworms).
- **Process:** The "toxin gene" from this bacterium is identified, isolated and inserted into the DNA of cotton or corn plants.
- **Result:** The plant starts producing this protein in its leaves and stems. When a pest feeds on the plant, the toxin enters its gut and kills it. This reduces the need for harmful chemical pesticides.

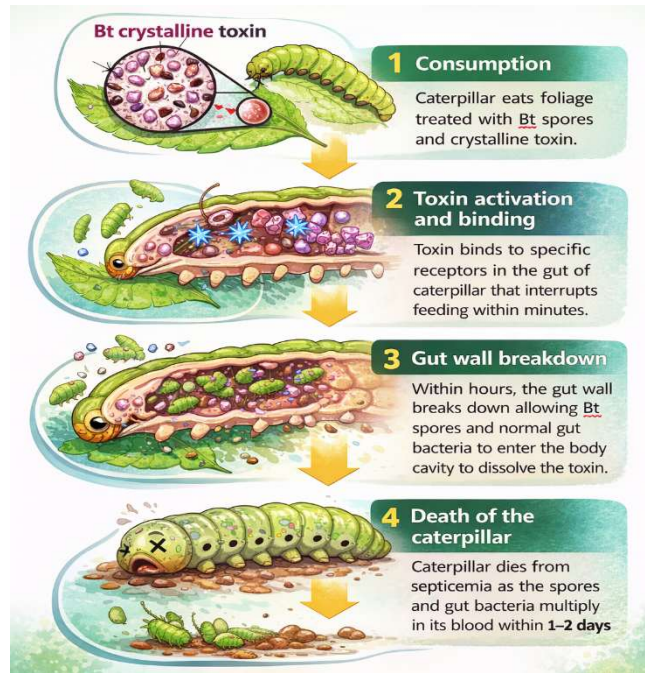

Figure 8: Action of *kurstaki* (Bt) on Caterpillars

10.4.1.2 Improving nutritional quality

Biotechnology has improved the nutritional content of key food crops. A prominent example is Golden Rice, genetically modified to produce high levels of beta-carotene, a precursor to vitamin A.

Golden Rice

- This bio-fortified crop helps fight malnutrition, especially Vitamin A Deficiency (VAD), which causes blindness in millions of children.
- **Problem:** Normal rice is a great source of energy but lacks Vitamin A.
- **Process:** Scientists inserted genes from maize (corn) and a soil bacterium into the rice plant. These genes allow the rice to produce beta-carotene, a precursor to Vitamin A.
- **Result:** The rice grains turn a golden-yellow colour because they are packed with beta-carotene, which our bodies convert into Vitamin A. It acts as a "medicinal food" for people in regions where rice is the main diet.



Figure 9: (A) Normal Rice and (B) Golden Rice

10.4.2 Medicine and Health Care

Making human insulin using bacteria is a brilliant piece of engineering. Instead of relying on animals, scientists "instruct" bacteria how to synthesize human insulin by giving them the right genetic instructions.

Steps:

DNA Isolation

Scientists have identified the specific human gene that contains the gene for making insulin. They use special biological "scissors" called **restriction enzymes** to cut this gene out of human DNA. This leaves "sticky ends" on the gene so it can attach to something else later.

Preparing the Plasmid

Bacteria have small, circular loops of DNA called **plasmids (extracellular DNA)**. Scientists take a plasmid and cut it open using the *same* restriction enzymes used for the human gene. This ensures the plasmid has matching "sticky ends" that fit the human insulin gene perfectly.

Combining the DNA (Ligation)

The human insulin gene is mixed with the cut bacterial plasmid. An enzyme called **DNA ligase** acts like biological glue, joining the two pieces together. This creates a **recombinant plasmid**— a modified DNA that now contains the human instructions for making insulin.

Creating the "Medicine Factory" (Transformation)

This recombinant plasmid is inserted back into a bacterium (usually *E. coli*). The bacterium is now "transformed" and ready to follow its new instructions.

Mass Production and Extraction

The engineered bacteria are placed into a large tank called a **fermenter**. As the bacteria replicate (multiply), they all carry the human insulin gene and begin to "express" it, meaning they start releasing human insulin protein in the culture medium.

Finally, the insulin is collected and purified to be safely used for diabetic patients.

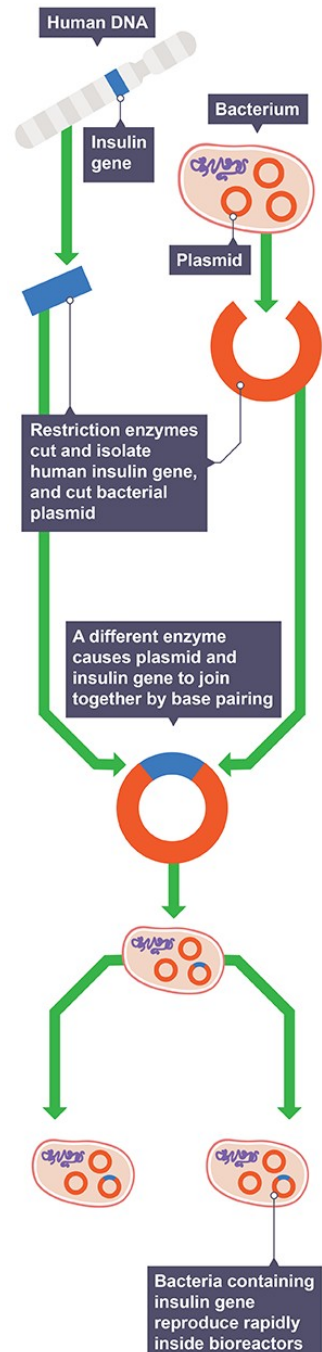

10.4.3 Food processing

Biotechnology plays a key role in the large-scale production of fermented foods like yoghurt, cheese, probiotics, buttermilk, idli, dosa, and dhokla. These products gain improved taste, enhanced nutrition like probiotics for gut health, added vitamins, and longer shelf life (via controlled microbial action). Microorganisms like *Lactobacillus* and yeasts are carefully selected, fermented under optimized conditions, and preserved to produce these foods safely and on a large scale.

10.4.4 Bio-Enzymes: Revolutionizing Household Cleaning

Biotechnology enhances household products through bio-enzymes, natural proteins derived from microbes like bacteria and fungi. These enzymes, such as proteases, amylases, and lipases, power everyday cleaners like laundry detergents, dishwashing liquids, and stain removers by breaking down tough dirt, grease, fats, and proteins at low temperatures—saving energy and reducing harsh chemical use. For instance, in washing powders, bio-enzymes target food stains or grass marks effectively, while in drain openers, they dissolve organic clogs safely without damaging pipes. This makes cleaning eco-friendly, skin-safe, and highly efficient for routine chores.

10.4.5 Environmental protection

Biotechnology contributes to environmental protection through targeted applications like bioremediation and biofuels.

Bioremediation

Microbes, engineered bacteria, or fungi break down pollutants such as oil spills, heavy metals, and pesticides in soil and water. This natural process restores ecosystems without harsh chemicals—for example, *Pseudomonas* bacteria degrade hydrocarbons from industrial waste.

Biofuels

Microbial fermentation converts biomass into renewable fuels like ethanol, biodiesel, or biogas. These alternatives reduce fossil fuel use and greenhouse gas emissions—algae systems even capture CO₂ while growing, aiding cleaner energy and waste management.

10.5. Bioreactors: Powering Large-Scale Biotechnology Applications

Biotechnology's diverse applications—from medicine and agriculture to food production—rely on scalable tools like fermenters (bioreactors) for industrial efficiency.

Fermenters (Bioreactors)

Fermenters are large vessels (up to 100,000 liters) made up of glass or steel that are used to grow microorganisms so as to produce a desired product. Example- A small culture of bacteria or yeast (**inoculum**) is added to fermenters containing nutrient medium to get useful products on a large scale.

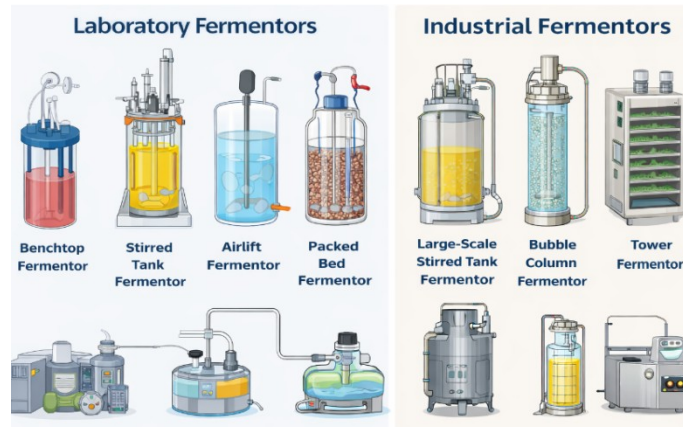

Figure 4: Fermenters in Laboratory and Industry

Fermenters must be **sterilized** before use so as to avoid the **contamination** of the rich nutrient culture.

10.5.1 Parts of fermenter-

- **Stirrer (Impeller)**- helps in agitation, i.e., mixes broth so that every cell gets the nutrients and oxygen.
- **Sparger**- Helps in aeration into the tank for the microbes to facilitate aerobic respiration.
- **Cooling Jacket**- Acts as a temperature control when microbes produce heat as they grow. The "cooling jacket" filled with cold water surrounds the tank to prevent the microbes from "cooking" themselves.
- **pH sensors**- Sensors monitor the change in pH. If the broth becomes too acidic, the system automatically adds a "base" to neutralize it.

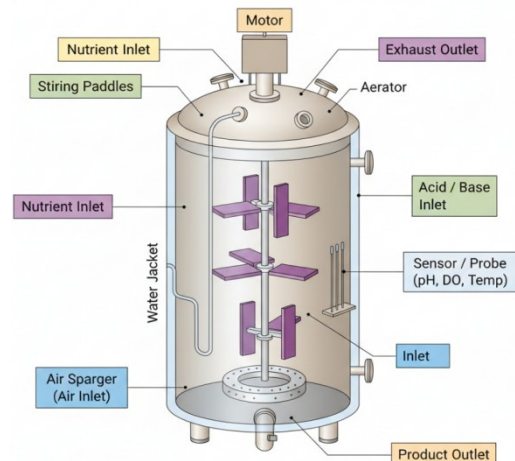

Figure 5: Parts of a fermenter

10.5.2 Fermentation Process

Preparation of Culture Medium



Sterilization of Medium and Equipment



Preparation of Pure Microbial Culture (Inoculum)



Growth of Microorganisms in a Fermenter (Under Controlled Conditions)



Extraction and Purification of Product



Treatment and Disposal of Waste Materials

Quick Check

1. Why is temperature control important in fermenters?
2. What happens if contamination occurs?
3. Explain sterilization and its importance in microbial growth.

10.5.3 Growth of Microorganisms in a Fermenter

Microbial growth does not occur at a constant rate. When nutrients are supplied in a fermenter, microbes pass through different phases of growth, which together form a growth curve.

The following are the phases of growth-

Lag Phase: The new inoculum is added to the nutrients in the fermenter, and the microbes adapt to the new environment. This phase is also called the **acclimatization phase**.

Log Phase: During this phase, microbial cells divide at their optimal rate, resulting in rapid population growth and maximum product formation. This phase is known as the **exponential phase**.

Stationary Phase: This phase is also known as the Survival Phase, wherein nutrients in the fermenters start depleting, and metabolic waste starts building up. Although new cells are being produced, an equal number of cells are dying.

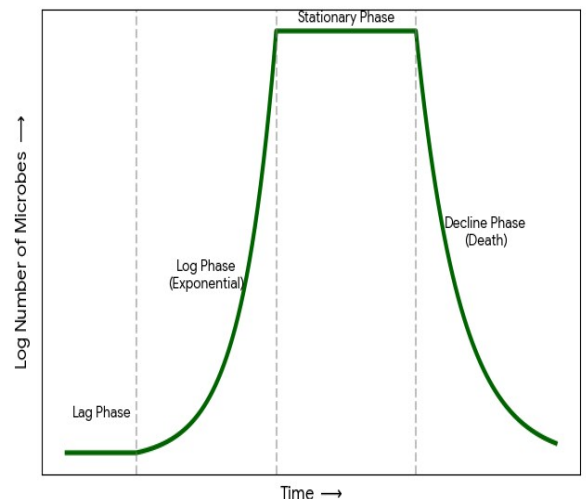

Figure 6: Microbial growth curve

Decline (Death) Phase or The End phase: The toxic waste levels become too high in the fermenter, and the population crashes.

To avoid the Decline (Death) Phase in a fermenter, engineers use a Continuous Culture system. Instead of a closed "batch," the environment is actively managed by:

- **Nutrient Replenishment:** Fresh nutrient medium is added continuously to ensure the microbes never run out of "fuel" for growth.
- **Waste Removal:** An equal volume of "spent" broth (containing toxic metabolic waste) is removed simultaneously. This prevents the buildup of toxins that would otherwise harm the population.
- **Steady State:** Nutrient replenishment and waste removal keep the microbes locked in the Log Phase, where they are most productive.
- **Automatic Buffering:** Sensors detect changes in pH and temperature. If acidic waste builds up, a base is automatically added to maintain a stable, life-supporting environment.

Let us explore like a scientist

Activity 5.4: Growth Simulation

The following table shows hypothetical data representing the growth of microorganisms in a fermenter.

| Time (hours) | Number of Microorganisms |
|---------------------|---------------------------------|
| 0 | 10 |
| 2 | 12 |
| 4 | 25 |
| 6 | 60 |
| 8 | 120 |
| 10 | 125 |
| 12 | 123 |
| 14 | 90 |

1. Using the above data, plot a graph using time (hours) on the X-axis and number of microorganisms on the Y-axis.
2. Identify and label the following growth phases on the graph:
 - Lag phase
 - Log phase
 - Stationary phase
 - Death phase

3. During which time period do microorganisms grow most rapidly?
4. Suggest one reason why the population decreases after a certain time.

10.6 Ethical Issues in Biotechnology

10.6.1 Safety: The risk of "Super-bugs" and ecological imbalance

When we try to engineer a microbe to kill a pest or to modify or extract proteins, we are actually introducing a new variable in the ecosystem. This may lead to unintended consequences and require biosafety measures.

Example-

- **Gene Flow:** Modifying genes could mix into the wild through cross-pollination in plants and lead to a risk that will be difficult to control. For example, a "weed-killer resistant" gene from a crop could transfer to a wild weed, creating a "super-weed" that no one can kill.
- **Targeting the Wrong Organisms:** A toxin meant to kill one specific pest might accidentally harm beneficial insects, like bees or butterflies, disrupting the entire food chain and food web.
- **Evolutionary Pressure:** Just as bacteria become resistant to antibiotics, pests can become resistant to the toxins in GM crops (like Bt Cotton), leading to the rise of "super-bugs" that are harder to control than ever before.

10.6.2 Equity: The Global "Biotech Divide"

Science is expensive. Because of the high cost of research and development, biotechnology is often regulated by a few powerful corporations and wealthy nations.

- **Patent Control:** Companies often "own" the seeds or the processes they create through patents. This can prevent poor farmers in developing countries from saving seeds for the next year, forcing them to buy new, expensive seeds every season.
- **Biopiracy:** This happens when researchers do unethical or unlawful appropriation or commercial exploitation of biological materials (such as medicinal plant extracts) that are native to a particular country or territory without providing fair financial compensation to the people or government of that country or territory.
- **Health Access:** Benefits of biotechnology may not reach the middle-income people, as the process and products developed are expensive and may only reach up to the top 1% of the global population, widening the gap between the rich and the poor.

Think and Discuss

There are four important ethical principles that help evaluate the impact of biotechnology on society. These principles act as guidelines to understand the benefits, risks and fairness related to emerging biotechnologies.

The figure shows different modern biotechnologies placed under four ethical principles:

- Beneficence (Doing Good)
- Non-maleficence (Do Not Harm)
- Autonomy (Freedom of Choice)
- Justice and Fairness

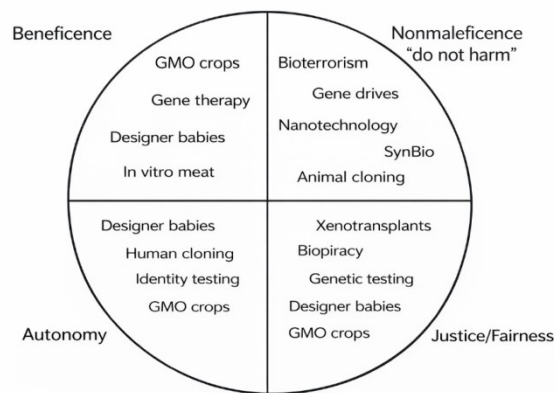

Each emerging biotechnology has been grouped under the principle where ethical concerns may arise. (*SynBio refers to Synthetic Biology.*)

Check Your Understanding

1. Define biotechnology. Explain how microorganisms act as “life’s engineers” giving two examples.
2. Differentiate between traditional biotechnology and modern biotechnology using suitable examples.
3. Why are fermenters used instead of open containers for industrial production of useful substances? Give any two reasons.
4. Explain the importance of maintaining sterility inside a fermenter. What problems may arise if sterility is not maintained?
5. Study the diagram of a fermenter in the chapter and answer the questions.
 - A. Identify any two parts responsible for maintaining microbial growth.
 - B. What is the function of the stirrer in a fermenter?
 - C. Why is oxygen supply important in some fermenters?
6. The following data shows the number of microorganisms growing in a fermenter.

| Time (hours) | Number of Microorganisms |
|--------------|--------------------------|
| 0 | 20 |
| 2 | 30 |
| 4 | 70 |
| 6 | 140 |
| 8 | 145 |
| 10 | 140 |
| 12 | 90 |

Answer the following:

- a) During which time period does rapid microbial growth occur?
 - b) Identify the stationary phase from the data.
 - c) Suggest one reason why the microbial population decreases after a certain time.
7. Microbes are used in food production, medicine and environmental protection. Analyse how biotechnology helps improve human life using any three examples.
 8. A scientist wants to produce insulin using bacteria. Explain how modern biotechnology makes this possible. Why has traditional biotechnology not achieved this?
 9. Biotechnology has helped increase food production, but some people have ethical concerns regarding GM crops. Evaluate both advantages and concerns.
 10. Design a simple biotechnology product that can help solve an environmental problem in your community. Describe:
 - The microorganism or enzyme you would use
 - The problem it solves
 - How it benefits society
 11. Which of the following is an example of traditional biotechnology?
 - a) Production of insulin using bacteria
 - b) Preparation of curd from milk
 - c) Development of disease-resistant crops
 - d) Gene transfer between organisms
 12. Which microorganism is commonly used in bread making?
 - a) Bacteria
 - b) Virus
 - c) Yeast
 - d) Algae

13. Which of the following conditions is necessary for proper functioning of a fermenter?
- a) Contamination
 - b) Controlled temperature
 - c) Open environment
 - d) Absence of nutrients
14. Genetic engineering mainly involves:
- a) Mixing different foods
 - b) Transfer of genes between organisms
 - c) Increasing natural microbial growth
 - d) Removing microorganisms from food
15. During which phase do microorganisms show maximum growth?
- a) Lag phase
 - b) Log phase
 - c) Stationary phase
 - d) Death phase

Assertion (A): Sterility must be maintained inside a fermenter.

Reason (R): Contamination by unwanted microorganisms can reduce product quality.

- a) Both A and R are true and R is the correct explanation of A.
- b) Both A and R are true but R is not the correct explanation of A.
- c) A is true but R is false.
- d) A is false but R is true.

Assertion (A): Modern biotechnology allows production of insulin using bacteria

Reason (R): Modern biotechnology involves genetic modification techniques.

- a) Both A and R are true and R is the correct explanation of A.
- b) Both A and R are true but R is not the correct explanation of A.
- c) A is true but R is false.
- d) A is false but R is true.

References:

1. <https://www.britannica.com/technology/biotechnology>
2. https://www.researchgate.net/figure/There-are-four-ethical-principles-that-may-be-used-as-guidelines-to-assess-the-ethical_fig3_316067580
3. https://agritech.tnau.ac.in/bio-tech/biotech_btotton_env.html
4. <https://www.sciencedirect.com/topics/engineering/fermenter>
5. <https://www.sciencedirect.com/topics/engineering/production-fermenter>
6. <https://ncert.nic.in/textbook.php?lebt1=2-13>
7. <https://www.cambridgeinternational.org/programmes-and-qualifications/cambridge-igcse-biology-0610/>
8. [https://bio.libretexts.org/Bookshelves/Human_Biology/Human_Biology_\(Wa_kim_and_Grewal\)/06%3A_DNA_and_Protein_Synthesis/6.08%3A_Biotechnology](https://bio.libretexts.org/Bookshelves/Human_Biology/Human_Biology_(Wa_kim_and_Grewal)/06%3A_DNA_and_Protein_Synthesis/6.08%3A_Biotechnology)
9. <https://pmc.ncbi.nlm.nih.gov/articles/PMC1868753/>
10. <https://www.cdc.gov/ecoli/about/index.html>
11. <https://media.sciencephoto.com/f0/30/28/70/f0302870-800px-wm.jpg>
12. <https://www.bbc.co.uk/bitesize/guides/zr3f7nb/revision/2>
13. <https://www.merriam-webster.com/dictionary/biopiracy>
14. Biotechnology – Textbook for class XI (NCERT Publication)

Social Science
Subject Code-087
Class - IX (2026-27)

RATIONALE

The purpose of the education system is to develop good human beings capable of rational thought and action, possessing compassion and empathy, courage and resilience, scientific temper and creative imagination, with sound ethical moorings and values. It aims at producing engaged, productive and contributing citizens for building an equitable, inclusive and plural society as envisaged by our Constitution. [NEP 2020, pages 4-5]

Social Science is a compulsory subject at Secondary Stage Phase-I of school education. Social Science can play a unique role within the school curriculum to enable Knowledge, Capacities, and Values and Dispositions that underpin the purpose of education as committed to in NEP 2020.

The teaching and learning of Social Science at the secondary stage is aligned with the transformational vision of the National Curriculum Framework for School Education (NCF-SE) 2023 and the National Education Policy (NEP) 2020. The NCF-SE 2023 emphasises learning, i.e., competency-based, inquiry-oriented, and rooted in Indian Knowledge Systems (IKS) and lived realities. The deliberate reduction of content load with a focus on core concepts rather than memorisation, creates space for discussion, exploration, and deep understanding. The framework's call for interdisciplinarity encourages students to draw meaningful connections across disciplines and relate classroom learning to real-life contexts and experiences.

Furthermore, the NCF-SE 2023 envisions rootedness in India, in which learning is grounded in India's diverse heritage and intellectual traditions, while also being combined with a global outlook. Within this perspective, Social Science education engages students with India's historical experiences, democratic values, and patterns of economic and social development, geographical understanding alongside global processes and contemporary challenges. By integrating the aims of the NEP 2020, Social Science education seeks to transform learning into a process that builds knowledge, capacities, and values essential for personal growth, social harmony and national progress.

Social Science at the secondary stage is an integrated study of human society like its evolution, structures, and dynamics through the disciplines of History, Geography, Political Science, and Economics. It explores how societies function and transform over time through the interplay of historical, geographical, cultural, political, economic, and environmental forces. The subject goes beyond the factual understanding to include inquiry, interpretation, and analysis.

Students learn to source and validate information, interpret data and evidence, and construct logical explanations, thus fostering critical and reflective thinking. It also cultivates empathy, respect for diversity, and a sense of justice and responsibility — values that reflect India's intellectual traditions of reasoning, dialogue, and debate as pathways to truth and understanding.

AIMS & OBJECTIVE

As per NCF- 2023, the aims of teaching Social Science in school education can be summarised as follows:

- a. Develop disciplinary knowledge and understanding of how society functions through an interplay of historical, geographical, social, economic, and political factors.

This can be enabled through:

- i. an understanding of continuity and change in human civilisation, its causation and effect and its impact on modern life.
 - ii. an understanding of the interaction between nature and human beings, the spatial patterns arising out of this interaction and its effect on human life.
 - iii. an awareness and understanding of the diversity of people and their practices in different societies, regions and cultures within societies.
 - iv. an awareness of various social, political and economic institutions, their origin, functioning and transformations over time.
- b. Develop an understanding and appreciation for the methods of enquiry relevant to Social Science and deepen students' skills to engage with the key questions and issues confronting society.

These could be specifically seen as:

- i. Skills in sourcing evidence, interpreting them, checking through multiple sources and evidences and constructing a coherent narrative.
 - ii. Skills in recognizing spatial patterns, map-reading, interpretation and analysis of various interconnected concepts and processes.
 - iii. Skills of creative and analytical thinking to form informed opinions, demonstrate logical decision-making and incline towards a problem- solving attitude.
 - iv. Skills to collect, organize, analyse, represent, and present data and information on various historical, geographical, and socio-political issues.
 - v. Skills to question unsubstantiated ideas, biases, stereotypes, and assumptions to foster scientific temper and propose meaningful responses to contemporary concerns of society.
- c. Foster ethical, human, and Constitutional values:

As the NEP 2020 emphasises to foster a “democratic outlook and commitment to liberty and freedom; equality, justice, and fairness; embracing diversity, plurality, and inclusion; humaneness and fraternal spirit; social responsibility and the spirit of service; ethics of integrity and honesty; scientific temper and commitment to rational and public dialogue; peace; social action through Constitutional means; unity and integrity of the nation, and a true rootedness and pride in India with a forward-looking spirit to continuously improve as a nation.

NOTE-Refer to NCF-2023-Page no-320-323

In alignment with the NEP 2020, Social Science education seeks to develop responsible human beings capable of rational thought and action, possessing compassion, empathy, courage, resilience, scientific temper, and creative imagination — qualities that prepare them to contribute meaningfully to the nation and humanity.

Studying Social Science is essential for developing informed, empathetic, and active citizens. It enables learners to situate themselves within broader social, cultural and environmental contexts, and to recognise their role in shaping them. Through this subject, students understand the origins of democratic values, Constitutional principles, and India's civilisational ethos of unity in diversity. They also develop awareness of pressing issues such as inequality, conflict, environmental degradation and economic challenges, and learn to respond to them with evidence-based reasoning and ethical reflection. Social Science thus, bridges knowledge and action, encouraging learners to think critically about society and participate responsibly and effectively in it.

CURRICULAR GOALS-CG

As per NCF 2023 - At the Secondary Stage, students will go into details to understand India's past and appreciate its complexity, diversity, and unity brought about by cultural integration and the sharing of knowledge traditions across geographical and linguistic boundaries. NCF 2023 Page no -154

- CG-1 Understands and analyses the important phases in Indian history and draws insights to understand present-day India
- CG -2 Analyses the important phases in world history and draw insight to understand the present-day world
- CG-3 Understands the idea of a nation and the emergence of the modern Indian Nation
- CG -4 Develops an understanding of the inter-relationship between human beings and their physical environment and how that influences the livelihoods, cultural diversity, and biodiversity of the region
- CG -5 Understand the Indian Constitution and explores the essence of Indian democracy and the characteristics of a democratic government.
- CG -6 Understand and analyse social, cultural, and political life in India over time – as well as the underlying historical Indian ethos and philosophy of unity in diversity – and recognises challenges faced in these areas in the past and present and the efforts (being) made to address them
- CG -7 Develop an understanding of the inter-relationship between human beings and their physical environment and how that influences the livelihoods, cultural diversity, and biodiversity of the region
- CG -8 Evaluate the economic development of a country in terms of its impact on the lives of its people and nature
- CG-9 Understand and appreciate the contribution of India through history and present times, to the overall field of Social Science, and the disciplines that constitute it

COMPETENCIES

Competencies are specific learning achievements that are observable and can be assessed systematically. In NCF, Competencies are directly derived from a Curricular Goal and are

expected to be attained by the end of a Stage. The following competencies need to be developed in students to achieve the curricular goals at secondary stage.

- CG-1.1 Explains the historical events and processes using different types of sources with specific examples from Indian history
- CG-1.2 Explains and analyses the chronology of human life on the Indian subcontinent, from prehistory to its civilisational beginnings and beyond, and its relations with other civilisations over time, such as those in Mesopotamia, Greece, Central Asia, China, Southeast Asia, Arabia, and Eastern Africa
- CG-1.3 Traces aspects of continuity and change in different phases of history across the Indian subcontinent (including cultural trends, social and religious trends and reforms, and economic and political transformations)
- CG-1.4 Explains the growth of new indigenous ideas across India in Mathematics, Philosophy, Science and Technology, Medicine, Architecture, Agriculture, Literature and Art, and Social Science (such as zero and the Indian number system, *ahimsa*, the six systems of Indian philosophy, Ayurveda, yoga, the 22 *shrutis* of Indian music, horticulture, use of herbs and spices, etymology, meters, and grammar) and how they affected the course of the Indian history
- C-2.1 Explains historical events and processes with different types of sources with specific examples from India and world history.
- C-2.3 Traces aspects of continuity and change in different phases of world history (including cultural trends, social and religious reforms, and economic and political transformations)
- C-2.4 Explains the growth of new ideas and practices across the world (including humanism, mercantilism, industrialisation, scientific developments and explorations, imperialism, colonialism, the rise of the new nation states across the world, and various technologies including the most current) and how they affected the course of world history.
- C-2.5 Recognises the various practices that arose, such as those in C- 2.4, and came to be condemned later on (such as racism, slavery, colonial invasions, conquests, and plunder, genocides, exclusion of women from democratic and other institutions), all of which have also impacted the course of world history and have left unhealed wounds.
- C 3.1 Analyses the meaning of nation and how the concept evolved over time across the world and in the specific context of India, including its roots in the rich civilisational history of the Indian subcontinent
- C3.2 Identifies and analyses important phases of the Indian national freedom struggle against British colonial rule, with special reference to the movement led by Mahatma Gandhi and other important figures as well as those that led to independence, and understands the specific Indian concepts, values, and methods (such as Swaraj, Swadeshi, passive resistance, fight for dharma self- sacrifice, *ahimsa*) that played a part in achieving Independence.
- C-4.1 Locates physiographic regions of India and the climatic zones of the world on a globe/map.
- C-4.2 Explains important geographical concepts, characteristics of key landforms, their origin, and other physical factors of a region
- C-4.3 Draws inter- linkages between various components of the physical environment, such as climate and relief, climate and vegetation, vegetation, and wildlife.
- C-4.4 Analyses and evaluates the inter- relationship between the natural environment and human beings and their cultures across regions and, in the case of India, the special environmental ethos that resulted in practices of nature conservation

- C-4.5 Critically evaluates the impact of human interventions on the environment, including climate change, pollution, shortages of natural resources (particularly water), and loss of biodiversity; identifies practices that have led to these environmental crises and the measures that must be taken to reverse them.
- C-4.6 Develops sensitivity towards the judicious use of natural resources (by individuals, societies, and nations) and suggests measures for their conservation
- C-5.1 Understands that the Indian Constitution draws from the great cultural heritage and common aspirations of the Indian nation, and recalls India's early experiments with democracy (assemblies in *Mahajanapadas*, kingdoms and empires at several levels of the society, guilds *sanghas* and *ganas*, village councils and committees, *Uthiramerur* inscriptions)
- C-5.2 Appreciates fundamental Constitutional values and identify their significance for the prosperity of the Indian nation.
- C-5.3 Explains that fundamental rights are the most basic human rights, and they flourish when people also perform their fundamental duties
- C-5.4 Analyses the basic features of a democracy and democratic government – and its history in India and across the world – and compares this form of government with other forms of government.
- C-5.5- Analyses the critical role of non-state and non-market participants in the functioning of a democratic government and society, such as the media, civil society, socio-religious institutions, and community institutions
- C-6.1 Understands how the Indian ethos and the cultural integration across India did not attempt uniformity, but respected and promoted a rich diversity in Indian society, and how this harmonisation and unity in diversity, with a historical respect for all cultures, women have counted among India's great strengths by promoting peaceful coexistence
- C-6.2 Understands that despite C-6.1, forms of inequality, injustice, and discrimination have occurred in different sections of society at different times (due to internal as well as outside forces such as colonisation), leading to political, social, and cultural efforts, struggles, movements, and mechanisms at various levels towards equity, inclusion, justice, and harmony, with varying outcomes and degrees of success.
- C 6.3 Analyses aspects of differential treatment or discrimination that may exist in the Indian society, based on, socio-cultural background, region, language spoken, and what individuals and societies can do to eradicate such differential treatment
- C 6.4 Understands that a progressive society and nation, such as India is one that recognises not only its civilisational strengths but also its socio-economic, cultural and political challenges, and continuously makes efforts to address those challenges to become ever more prosperous, inclusive, just, and harmonious
- C-7.1 Defines key features of the economy, such as, production, distribution, demand, supply, trade, and commerce, and factors that influence these aspects (including technology)
- C-7.2 Evaluates the importance of the three sectors of production (primary, secondary, and tertiary) in any country's economy, especially India
- C-7.3 Distinguishes between 'unorganised' and 'organised' sectors of the economy and their role in production for the local market in small, medium, and large-scale production centres (industries), and recognises the special importance of the so-called 'unorganised' sector in

Indian economy and its connections with the self-organising features of Indian society

- C-7.4 Traces the beginning and importance of large- scale trade and commerce (including e- commerce) between one country and another - the key items of trade in the beginning, and the changes from time to time.
- C-8.1 Gathers, comprehends and analyses data related to income, capital, poverty, and employment in one's locality, region and at the national level. Markets.
- C- 8.2 Understands and analyses the concepts and practices of the range of economic systems — from free market to entirely state-controlled markets.
- C-8.3 Understands these features in the context of ancient India, with its thriving trade, both internal and external, and its well- established trade practices and networks, business conventions, and diverse industries, all of which made India one of the world's leading economies up to the colonial period
- C-8.4 Describes India's recent path towards again becoming one of the three largest economies of the world, and how individuals can contribute to this economic progress.
- C-8.5 Appreciates the connections between economic development and the environment, and the broader indicators of societal wellbeing beyond GDP growth and income.
- C – 9.1 Knows and explains the significant contributions of India to all matters (concepts, explanations, methods) studied within the curriculum, in an integrated manner

Pedagogy for teaching geography should integrate experiential, visual, and analytical approaches to make learning more meaningful and connected to the real world. Effective geography teaching goes beyond textbooks- it involves helping students observe, analyse, and interpret the Earth's surface and human-environment relationships. The use of three-dimensional models enables students to visualise complex geographical processes, such as mountain formation, river systems, and soil profiles, thus making abstract concepts tangible. Field observation is an essential pedagogical tool that promotes experiential learning; by directly engaging with local landscapes, students develop geographical inquiry skills, observation techniques, and data collection abilities. Incorporating Bhuvan images, India's indigenous satellite imagery and mapping platform allow learners to explore their own regions using real-time geospatial data and satellite views, linking classroom knowledge to local realities. Map reading is another fundamental component, as it cultivates spatial awareness, orientation, and the ability to interpret symbols, scales, and coordinates. Likewise, photo interpretation — analysing aerial and satellite photographs — helps students understand the land-use patterns, vegetation cover, urbanisation, and environmental changes. When combined, these methods foster critical thinking, spatial reasoning, and a deeper appreciation of the dynamic Earth systems that geography seeks to explain.

For understanding the past and India's rich heritage, teachers are expected to engage students in the following ways. Firstly, they are expected to analyse inscriptions or edicts (for example, Ashoka's edicts, and Gupta records) to understand how rulers communicated policies, messages, and ethical guidelines to their subjects. Secondly, they are to encourage students to read excerpts or chapters from Indian literary sources that throw light on the social, cultural, and political life of people. Thirdly, they are expected to conduct research and present examples of forts, temples, mosques, and palaces to illustrate cultural, architectural, and political developments in the Indian history. Finally, the teachers should explore and discuss the works of artists and philosophers of the Renaissance period, highlighting their contributions and influence.

Students should be made to locate the extent of various important empires on a world map. They are also expected to investigate and explain the key Indian ideas that shaped the thinking of Western philosophers, scientists, and artists. Finally, students should be encouraged to use a world map to trace India's trade and cultural exchanges with other civilisations, and analyse their patterns and impact.

Transaction of political concepts requires connecting students with evidence, inquiry, and real-world reasoning. Document-based inquiry helps learners explore authentic sources, such as Vedic texts, constitutional excerpts, and letters from national leaders to interpret historical contexts and moral reasoning. Case-based pedagogy, using landmark judgments, maps, and data analysis, builds decision-making and analytical skills, encouraging students to apply theory to practice. Evidence-based learning engages learners with real datasets from Census, NITI Aayog, or UNDP reports to develop data literacy and link concepts like equality and representation with measurable realities. Further, multimedia and experiential approaches use podcasts, documentaries, and archival materials to connect abstract political ideas with real experiences, sharpening students' interpretive and critical listening skills. Visual and graphic organiser-based pedagogy-through charts, tables, and concept maps — supports comprehension, memory, and summarisation by converting complex ideas into structured visuals. Together, these pedagogies transform classrooms into laboratories of civic thinking, empathy, and inquiry. They nurture students as reflective citizens who can interpret evidence, question assumptions, and engage meaningfully with India's democratic processes.

The pedagogy for teaching Economics needs to be interactive, experiential, and inquiry-driven, enabling students to relate economic concepts to real-life situations. Teachers can use role-play activities — such as running a lemonade stall or simulating the circular flow of income with students acting as households, firms, banks, and the government to make ideas like production, income, and expenditure tangible. Class discussions on familiar issues, such as rising vegetable prices during monsoons, help students link classroom learning with everyday experiences and develop critical thinking. Engaging classroom activities and games, like preparing a classroom budget, allow students to understand scarcity, choice, and opportunity cost in a fun and participatory way. The use of visual tools — including maps, pie charts, and graphs — can help students analyse data on GDP, trade, and sectoral trends. The case studies on topics like pollution as an externality, public goods like street lights, or successful entrepreneurs encourage application and deeper reflection. Surveys and field visits to local shopkeepers or MSMEs further bridge theory and practice by exposing students to real market dynamics. Incorporating current resources, such as newspaper articles or the Union Budget fosters analytical skills and awareness of contemporary economic issues. Through this diverse, hands-on approach, learners will move beyond memorisation to active understanding, making Economics relevant, engaging, and empowering

COURSE OUTLINE

Class IX-2026-27

Part 1

| S. No. | Theme (time allocation in instructional hours) | Outline/Concepts | Learning Outcomes and Competencies Students will be able to: |
|--------|--|---|---|
| 1. | Understanding Social Science (4 Hours) | <ul style="list-style-type: none"> • Meaning, scope and relevance of Social Science • Understanding Social Science from an Indian perspective | <ul style="list-style-type: none"> • Explain the relevance of studying Social Science to understand society, environment, economy, and governance in our lives. • Explain the meaning and scope of Geography, History, Political Science, and Economics as disciplines and recognise their interconnections. • Appreciate diversity, inclusivity, sustainability, and equity as guiding values when studying society and making decisions. |
| 2. | Shaping of the Earth's Surface (8 Hours) | <ul style="list-style-type: none"> • Theory of plate tectonics • Interior of the Earth • Role of weathering and erosion; agents of gradation — river, waves and currents, wind, glaciers, and underground water • Landforms and disasters: earthquakes, landslides, avalanches, Glacial Lake Outburst Flood (GLOF) and duststorms | <p>C4.2</p> <ul style="list-style-type: none"> • Describe the concept of plate tectonics and analyse its relevance in understanding Earth's dynamics. • Locate major tectonic plates on a world map. • Explain processes of weathering and erosion with suitable examples. • Identify the prominent agents of gradation operating in a given region. • Describe major landforms and explain the processes involved in their formation. • Explain the causes of natural disasters and propose strategies for their mitigation. |
| 3. | Atmosphere and Climate (7 Hours) | <ul style="list-style-type: none"> • Structure and composition; elements of weather and climate • Seasons of India and monsoons • Climate change • Floods • Carbon footprint | <p>C4.3, C4.4, C4.5</p> <ul style="list-style-type: none"> • Explain the different atmospheric layers and represent them using sketches and diagrams. • Observe and analyse local winds and their impact. • Understand the impact of the Indian monsoon on life, agriculture, and livelihoods across different regions. |

| | | | |
|----|--|--|---|
| | | | <ul style="list-style-type: none"> • Explain the causes and effects of climate change. • Represent climatic data (temperature, rainfall, etc.) through appropriate graphs, charts, or diagrams. • Analyse how climate change influences the frequency and intensity of natural disasters. |
| 4. | Early Humans and Beginning of Civilisation (9 Hours) | <ul style="list-style-type: none"> • Cultural development from 2 million years ago • Early human history, periodisation: Archaeological ages • Who are human ancestors? • Palaeolithic hunter-gatherers and use of stone tools | <p>C1.2, C2.1, C2.2, C2.3</p> <ul style="list-style-type: none"> • Describe how prehistoric time divisions are organised. • Explain how humans lived before the invention of writing • Understand the beginning of the settled life with development of agriculture, and domestication of plants and animals. • Explore the factors of urban development and transformation through time. |
| | | <ul style="list-style-type: none"> • Mesolithic transition to food production: Mesolithic sites and tools • Neolithic and the beginning of farming: Neolithic revolution domestication of plants and animals • Harappan and contemporary cultures • Mesopotamian, Egyptian, and Chinese civilisation | <ul style="list-style-type: none"> • Appreciate the diversity of crafts and trade, and their role the establishment of prosperous economy. • Understand the diversity of food habits. • Describe the social, political, and religious structures of the civilisations of Egypt and Mesopotamia. |
| 5. | State and Society (upto 1000 CE) (9 Hours) | <ul style="list-style-type: none"> • Vedic Age — geography; texts; rituals; political institutions, and social order • Administrative structure of early empires • Quest for knowledge — educational heritage, institutions, knowledge traditions, and cultural practices | <p>C1.3, C2.3, C3.1, C1.4</p> <ul style="list-style-type: none"> • Explain various facets of Vedic society and polity. • Appreciate the achievements of Indian empires and their cultural legacy. • Understand the knowledge traditions and practices of India. • Understand the foundations of the Indian social and political institutions and their continuity. |

| | | | |
|----|--|--|--|
| | | <ul style="list-style-type: none"> • Traders and trade routes, guilds and merchants, crafts and industries | |
| 6. | Democracy (9 Hours) | <ul style="list-style-type: none"> • Meaning features and types of democracy • Roots of democracy in India • Challenges to democracy in India • Democratic systems in the world | <p>C5.1, C5.2</p> <ul style="list-style-type: none"> • Understand the features of democracy. • Appreciate early democratic traditions in India and how they influenced modern democracy. • Differentiate between parliamentary and presidential systems. • Identify examples of both systems across countries, such as India, USA, France, Russia, and Canada. |
| 7. | Elections (9 Hours) | <ul style="list-style-type: none"> • Factors of importance of elections • Electoral systems • Delimitation Commission • Election Commission of India and its role • Constituency, electoral rolls, enumerators • Party system in India | <p>C5.2, C5.3, C5.4, C5.5, C6.2, C6.3, C6.4, C9.1</p> <ul style="list-style-type: none"> • Identify factors highlighting importance of elections in a democracy. • Categorise three types of electoral systems and list examples. • Identify the major laws that govern the conduct of elections in India. • Describe the main provisions of the Representation of the People Acts. • Define the concept of delimitation and its purpose in the Indian electoral system. • Identify the role and functions Election Commission of India (ECI) in the electoral process. • Explain constituency, electoral roll, enumerator. • Understand the party system in India. • Explain the meaning and features of a coalition government in the Indian political system. Explain key provisions of the Anti-Defection Law with reference to political instability and the need for anti-defection measures. |
| 8. | Building Blocks in Economics (7 Hours) | <ul style="list-style-type: none"> • Scarcity of resources, opportunity cost and the need for making choice. What do economists do? | <p>C8.2</p> <ul style="list-style-type: none"> • Explain the meaning of scarcity, choice, and opportunity cost in everyday life, and economic decision-making. • Describe what economists do and how they study production, distribution, and consumption of goods and services. |

| | | | |
|----|--|--|---|
| | | <ul style="list-style-type: none"> • What to produce, how to produce, and for whom to produce? • Difference between market, centrally planned, and mixed economic systems • Welfare economy | <ul style="list-style-type: none"> • Recognise how economic analysis helps in policy-making and solving real-world issues. • Describe the three central problems of an economy — what to produce, how to produce, and for whom to produce. • Identify and differentiate the characteristics of planned, free market, and mixed economic systems. • Explain the concept of a welfare economy and the importance of social safety nets. |
| 9. | The Price Puzzle: What Drives the Market (8 Hours) | <ul style="list-style-type: none"> • Laws of demand and supply • Real-world deviations from textbook theory, such as in case of necessities, luxury goods, perishable items, and expectations • Some related concepts — price ceilings and market failures (externalities, information asymmetry, public goods) | <p>C7.1</p> <ul style="list-style-type: none"> • Explain the Law of Demand and Law of Supply with the help of real life examples. • Interpret how changes in price affect the quantity demanded and quantity supplied of goods and services. • Identify the equilibrium price and quantity where demand and supply intersect. • Analyse how changes in market conditions (e.g., increase in demand or supply) lead to surplus or shortage and affect equilibrium. • Explain the concept of price ceilings and how they can lead to shortages or black markets. • Understand market failures and identify their main types. • Understand public goods (non-excludable and non-rival goods like parks or street lighting). |

Part 2

| S. No. | Theme (time allocation instructional hours) | Outline/Concepts | Learning Outcomes (pertinent) CGs, Cs Students will be able to: |
|--------|---|--|---|
| 1. | Oceans and Life (7 Hours) | <ul style="list-style-type: none"> • Introduction to ocean relief, movement of ocean water- waves, tides and currents • Marine resources and their significance; open seas, navigation fishing, and livelihood concerns and challenges • Cyclones and | <p>C4.1, C4.2</p> <ul style="list-style-type: none"> • Explain the movement of ocean waters, including waves, tides, and currents. • Analyse the connections between ocean currents, and global and regional climate patterns. • Understand the importance of marine resources for human livelihoods and ecosystems. • Examine the relationship between oceans, climate, livelihoods, and natural disasters. • Highlight key rules, conventions, and |

| | | | |
|----|---|---|---|
| | | <p>Tsunamis — early warning systems</p> <ul style="list-style-type: none"> • International maritime rules and regulations | <p>international agreements governing ocean navigation. and the use of marine resources.</p> <ul style="list-style-type: none"> • Explain the need for international cooperation and agreements in the sustainable use of ocean resources. • Construct models or sketches representing ocean relief. |
| 2. | Life on Earth (7 Hours) | <ul style="list-style-type: none"> • Biomes: Distribution and characteristics; biosphere reserves in India • Forest and ecotourism; forest dwellers, their livelihoods, and challenges • Forest and wildlife conservation • Government efforts to support forest dwellers | <p>C4.3, C4.4, C4.5, C4.6</p> <ul style="list-style-type: none"> • Identify the major biomes of the world and describe their key climatic conditions, characteristic flora, and fauna. • Locate biosphere reserves on the map of India. • Appreciate local traditional practices related to biodiversity conservation and analyse their effects. • Explain the concept and importance of biosphere reserves in conserving ecosystems and biodiversity. • Analyse the concept of ecotourism and discuss its role in promoting sustainable forest ecosystem and conservation. • Investigate the causes of forest fires in the local area, and prepare a plan for mitigation and prevention. |
| 3. | Resistance and Resilience (1000 CE – 1700 CE) (9 Hours) | <ul style="list-style-type: none"> • Safeguarding sovereignty: resistance, alliances and confederacies • Development of art and architecture, languages and literature • The Bhakti tradition • Forts and fortifications • Expansion of Indian economy and state | <p>C1.3, C1.4, C3.1</p> <ul style="list-style-type: none"> • Explain the cultural, political, and military contributions of regional kingdoms in India. • Appreciate how diverse communities and regions shaped India's history from 1000 CE to 1700 CE. • Explore how regional kingdoms adapted to changing political, economic, and cultural contexts over time. • Analyse the continuity of the civilisational history of India as a nation upto 18th century CE. |
| 4. | India and the World-I (1900 BCE- 1200 CE) (8 Hours) | <ul style="list-style-type: none"> • Trade and commerce — trade with Mesopotamia, Greece, Roman Empire, China and Southeast Asia • Cultural Connections — Interactions with Greece and Rome, Central Asia, China, and Influence on South East Asia | <p>C1.2, C1.4, C6.1, C2.3, C9.1</p> <ul style="list-style-type: none"> • Explore India's relations with early civilisations of the world. • Identify the major articles of trade and the major trading ports. • Appreciate the significant contributions of India in diverse spheres in an integrated manner. • Appreciate the influence of Indian religion and culture, particularly in Southeast Asia. |

| | | | |
|----|----------------------------------|---|--|
| | | <ul style="list-style-type: none"> • Indian Knowledge Systems — Medicine, Mathematics and Astronomy, Medicine, Religion | |
| 5. | Authority (10 Hours) | <ul style="list-style-type: none"> • The Roots of Authority: in Kautilya and <i>shukraniti- danda</i> and relationship with <i>nyaya</i> and <i>bala</i>; the types of <i>nyaya</i> and <i>bala</i> • Constitutional status of justice and security since ancient times • Links the role of citizens with the elections and the democratic institutions • Types of authority — functional, sensitive, and welfare-oriented | <p>C5.1, C5.2, C 5.3</p> <ul style="list-style-type: none"> • Explain the roots of authority in Indian political thought. • Interpret the relationship between <i>Danda</i> (discipline/ force) and <i>Nyaya</i> (justice) as the twin foundations of authority, development, and security. • Trace the evolution of authority structures in India. • Understand the post- independence concept of justice and security. • Illustrate types of authority. • Develop an understanding of citizen discipline, justice, and strength. • Illustrate the role of citizens in authority. |
| 6. | From Ideas to Startups (8 Hours) | <ul style="list-style-type: none"> • What is entrepreneurship and explain the resources required to start a business • Case studies of successful entrepreneurs • Creative destruction with examples • Start-up ecosystem in India. • Make in India initiative, role of MSMEs and the unorganised sector in India's economic growth. • Stages of starting and executing a business idea through a business plan • Some basic accounting concepts | <p>C7.3</p> <ul style="list-style-type: none"> • Define entrepreneurship and explain its importance in innovation, job creation, and economic growth. • Understand the key resources for business. • Explain how resources are managed to produce goods and services. • Analyse real-world examples of successful entrepreneurs. • Describe the features of India's start-up ecosystem and initiatives like Make in India, Startup India, and Digital India. • Recognise the role of Micro, Small, and Medium Enterprises (MSMEs) and the unorganised sector in promoting employment, innovation, and inclusive growth. • Identify and explain the stages of starting a business from developing an idea to creating and executing a business plan. • Understand simple profit and loss. Identify the key components of a balance. |

| | | | |
|----|--|---|--|
| 7. | Smart Ways to Manage Your Finances (6 Hours) | <ul style="list-style-type: none"> • Relevance of personal financial management in daily life • Inflation and its impact on purchasing power • Simple vs. compound interest rate • Budgeting • Various savings and investment options like fixed deposit, stocks, bonds, mutual funds, etc. • Risk and insurance • Personal income tax | CG8 <ul style="list-style-type: none"> • Explain what personal financial management means and why it is essential in everyday life. • Recognise how managing income, spending, saving, and investment helps achieve financial stability and long-term goals. • Explain the difference between simple interest and compound interest. • Prepare a simple personal or family budget showing income, expenditure, and savings. • Identify various savings and investment instruments. • Understand the relationship between risk and return in different investment types. • Understand the concept of income tax and why citizens are required to pay it. |
|----|--|---|--|

Note-Course Structure will be provided shortly

CLASS IX (2025-26)
INTERNAL ASSESSMENT: 20 MARKS

| Type of Assessment | Description | Marks |
|-----------------------------|--|-------|
| Periodic Assessment | Pen Paper Test | 5 |
| Multiple Assessment | Quiz, debate, role play, viva-voce, group discussion, visual expression, interactive bulletin boards, gallery walks, exit cards, concept maps, peer assessment, self- assessment etc. through interdisciplinary project , Report Writing on field visits, Commentaries/visual interpretations, site-map making | 5 |
| Subject Enrichment Activity | Project work (Interdisciplinary) | 5 |
| Portfolio | Classroom, work done (activities/assignments) reflections, narrations, journals etc. Achievements of the student in the subject throughout the year. Participation of the student in different activities like Heritage India quiz etc. | 5 |

CLASS IX
PRESCRIBED TEXT BOOKS

| S. No. | Name of the Book | Publisher |
|--------|-----------------------|-----------|
| 1 | Social Science-Part 1 | NCERT |
| 2 | Social Science-Part 2 | NCERT |

Physical Education and Well-being

Grade 9

Session 2026-27

Max. Marks: 100

Time: 3:00 Hours

Theory: 20 Marks, Practical: 80 Marks

Introduction

Physical Education and Well-being is an essential component of holistic education that promotes balanced development of physical, mental, emotional, and social dimensions of learners. In the present era of rapid technological advancement, academic pressure and sedentary lifestyles, the subject plays a critical role in nurturing healthy habits, physical literacy, emotional resilience, and positive social behaviour among students. It prepares learners not only for physical fitness but also for meaningful participation in society as confident, responsible, and ethical individuals.

The scope of Physical Education and Well-being extends beyond sports and physical exercise. It encompasses fitness management, movement skills, emotional regulation, teamwork, leadership, value-based living and holistic well-being. Structured physical activities, games, and reflective practices develop essential life skills, such as self-discipline, perseverance, cooperation, empathy, decision-making, and critical thinking. These skills contribute to the overall well-being, and support lifelong engagement in healthy and active lifestyles.

With increasing societal emphasis on excellence in holistic health, fitness and sports, Physical Education and Well-being addresses contemporary challenges, such as lifestyle-related diseases, mental stress, social inequality, and exclusion. The subject promotes values of fairness, inclusivity, gender equality, respect for diversity, ethical conduct, and social responsibility. It encourages students to develop self-awareness, regulate emotions, and build healthy relationships, thereby contributing to personal and social well-being.

Nature of the Subject

Physical Education and Well-being is a dynamic, experiential, and value-oriented subject that plays a vital role in the holistic development of learners. It recognises movement as a powerful medium for learning and self-expression.

The subject is interdisciplinary, drawing on knowledge from the biological sciences, psychology, sociology, health sciences, technology, and environmental studies. Learners explore how physical activity influences body systems, mental processes, behaviour and social interactions, connecting theory with practice through active participation, observation and reflection.

Physical Education and Well-being is an inclusive and learner-centric subject, catering to diverse abilities, interests, genders, and cultural backgrounds. It promotes equity, accessibility, and participation for all, including children with disabilities and special needs. Through games and sports, students learn ethical behaviour, fair play, discipline, perseverance, humility in success, and grace in defeat, while also developing confidence, self-esteem, and emotional intelligence essential for personal and academic success.

Physical Education serves as a vehicle for character building, providing opportunities for self-regulation, goal setting, critical thinking, and problem-solving in real-life situations. The pedagogy is learner-centric and inclusive, with learning taking place through direct participation, inquiry, discussion, and reflection. Activity based learning, project work, discovery-oriented approaches, and collaborative practices enable students to connect theoretical knowledge with real-life experiences.

Nature of Knowledge in this Subject

Knowledge in Physical Education and Well-being is experiential, applied, interdisciplinary, and transformative. Unlike purely theoretical subjects, collaboration in Physical Education is based on learning through movement, practice, thinking about one's actions, and learning with others. Knowledge is constructed through doing, observing, analysing, and reflecting on physical activity experiences, thereby enabling learners to internalise concepts meaningfully and apply them in real-life contexts.

The knowledge acquired is dynamic and evolving, and is continuously influenced by advancements in sports science, health research, digital technologies, and changing societal needs. The nature of knowledge encompasses four interconnected dimensions:

- **Conceptual Knowledge:** This includes understanding the principles of health, physical fitness, movement, wellness, nutrition, behaviour, and human body systems. Learners gain insights into growth and development, physiological responses to exercise, injury prevention, mental well-being, and the relationship between physical activity and overall health. Conceptual knowledge provides the scientific and theoretical foundation necessary for informed decision-making regarding lifestyle and fitness.

- **Practical Knowledge:** Practical knowledge is developed through hands-on participation and skill acquisition. It involves learning and refining motor skills, sport-specific techniques, movement patterns, game rules and strategies, and safe practices during physical activity. Students also acquire essential life skills, such as First Aid, Basic Life Support (BLS), Cardiopulmonary Resuscitation (CPR), and safety protocols, enabling them to respond responsibly in emergencies and promote a safe supporting environment.

Reflective Knowledge: Reflective knowledge enables learners to evaluate their physical, emotional, and behavioural responses during and after physical activities. Through self-assessment, fitness tracking and reflective journals, students analyse their strengths, limitations, habits, and attitudes. This dimension also fosters awareness of ethical conduct, fair play, inclusivity, respect, discipline and value formation, supporting character development and emotional intelligence.

- **Social Knowledge:** Social knowledge focuses on understanding the role of physical activity like sports in society. Learners explore how sports contribute to nation-building, cultural identity, community engagement, and global harmony. This includes the responsible and meaningful use of leisure time, the promotion of gender equity and equality, the inclusion of persons with disabilities, accountability, affordability, and the appreciation of diversity. Students also learn about teamwork, leadership, cooperation, and citizenship through shared physical experiences.

Knowledge of Physical Education and Well-being empowers learners to develop lifelong healthy behaviours, ethical values, social responsibility, and self-confidence. It supports holistic growth by integrating physical competence with mental awareness, emotional balance, and social sensitivity, preparing students to lead active, healthy, and purposeful lives in a rapidly changing world.

Physical Education and Well-being Grade 9 (Session 2026-27)

Max. Marks: 100

Time: 3:00 Hours

Theory: 20 Marks, Practical: 80 Marks

| Curricular Goals | Competencies | |
|---|--------------|--|
| Learning Standard 1 | | |
| CG-1 Demonstrates a high level of competence in the understanding of movement concepts, strategies, and principles, while engaging and performing in physical activities, including sports and dance. | C1.1 | Exhibits proficiency in all movement and motor skills required to participate and excel in at least one sport, yoga or any other physical activity (team, dual, individual). |
| | C1.2 | Explains the role of rhythmic drills to improve their game. |
| | C1.3 | Exhibits the ability to use complex movement concepts and principles to develop and refine their games or sports skills. |
| | C1.4 | Exhibits and explains the manipulation of space and equipment in the context of a game. |
| | C1.5 | Applies knowledge and understanding of movements, and skills to develop a physical activity plan for themselves, follow a routine and assess independently. |
| CG-2 Exhibits sensitivity and learns to manipulate their personal and social behaviour towards themselves and others. | C2.1 | Reflects upon their and others' behaviour before, during and after the physical activity in the long term. This may include different but related behaviours, including emotional state of mind, physical fitness, fatigue, fair play, biases, and personal interests. |
| | C2.2 | Articulates the importance of emotional and mental support to others, as well as, improving performance and encouraging others to perform by analysing the behaviour of student when someone is emotionally or physically hurt, and how their support may improve others' performance. |
| | C2.3 | Modifies and creates new games and rules that are more inclusive in nature. |
| | C2.4 | Creates and applies safety rules, protocols for physical activity, and visualises how they can be applied outside the field as well. |
| | C2.5 | Demonstrates fairness and responsible behaviour in tough contexts and situations. |
| | C2.6 | Exhibits modesty after an exceptional performance, accepts defeat gracefully and enjoys the game. |
| CG-3 Demonstrates social sensitivity and mental engagement in physical activity and game situations. | C3.1 | Designs and uses multiple strategies in a game and can make new strategic moves in challenging game situations (for example, a student's plan A and B, both failed and strategise a plan C during the game). |
| | C3.2 | Understands and deals with their and others' emotions, and the thinking process during the game. |
| | C3.3 | Demonstrates calmness and courage in difficult situations, and is able to calm their teammates. |
| | C3.4 | Regulates the intensity in different situations. |

| | | |
|--|------|--|
| CG-4 Plans personal physical fitness goals independently and monitors them. | C4.1 | Sets multiple physical activity and fitness goals, such as improving multiple shots or their overall match performance. |
| | C4.2 | Assesses their progress in terms of efforts, processes, and outcomes. |
| | C4.3 | Prepares, plans, and schedules their exercises and warm-ups in consultation with their teacher to get maximum benefits. |
| CG-5 Learns about the value of physical activity for health, enjoyment, challenge, expression, and social interaction. | C5.1 | Illustrates the role of physical education for positive social interaction, while discussing physical activity throughout history and culture. |
| | C5.2 | Examines the role of physical activity in improving self-confidence and self-esteem. |
| | C5.3 | Appreciates the aesthetic appeal of a performance, such as someone's classy straight drive, a beautiful free kick, an effortless smashing of the ball, a well-placed drop shot, or a speedy smash. |
| | C5.4 | Expresses self through dance, gymnastics, or any physical activity. |
| CG-6 Assesses their growth and development. | C6.1 | Examines the role of different factors which affect growth and development, such as heredity, immediate environment, diet, diseases, state of mind and physical activity. |
| | C6.2 | Analyses the relationship of nutrition, physical activity, and mental health with skeletal health, muscles, strength, endurance, flexibility and agility. |
| | C6.3 | Classifies the common injuries of bones and muscles, and describes the protocol for seeking medical help for themselves and others when needed like providing first-aid in such situations. |
| | C6.4 | Outlines and challenges the societal beliefs and taboos associated with different aspects of growth, and development in the adolescent age. |
| CG-7 Learns about tournaments at the international, national, state, district, and block levels. | C7.1 | Charts the various tournaments at international, national, state, district and block levels. |
| | C7.2 | Describes the participation criteria and rules of tournaments. |
| | C7.3 | Summarises the support or organisational structures to participate in tournaments. |
| | C7.4 | Explains the different forms and procedures for participating in tournaments. |

Learning Standard 2

| | | |
|---|------|---|
| CG-1 Demonstrates competence in the understanding | C1.1 | Exhibits all movements and motor skills required to participate and play in at least one sport, yoga or any other physical activity (team, dual, individual). |
|---|------|---|

| | | |
|--|------|--|
| of movement concepts, strategies and principles, while engaging in and performing physical activities, including sports. | C1.2 | Exhibits the ability to use complex movement concepts and principles to develop and refine one's game and sports skills. |
| | C1.3 | Applies knowledge and understanding of movements, and skills to develop their own physical activity plan, follows a routine and assesses independently. |
| CG-2 Exhibits sensitivity and learns to regulate their personal and social behaviour towards themselves and others. | C2.1 | Reflects upon their and others' behaviour before, during, and after the physical activity. This may include different but related behaviours, including emotional state of mind, physical fitness, fatigue, fair play, biases, and personal interests. |
| | C2.2 | Articulates the importance of a team member's support to improve performance in the game, by analysing the behaviour of students when someone is emotionally or physically hurt, and how their support may enhance the performance of others. |
| | C2.3 | Modifies and creates new games and rules that are more inclusive in nature. |
| | C2.4 | Creates and applies safety rules and protocols for physical activity and visualises how they can be applied outside the field as well. |
| | C2.5 | Demonstrates fairness and responsible behaviour in tough contexts and situations. |
| | C2.6 | Exhibits modesty after an exceptional performance, accepts defeat gracefully, and enjoys the game. |
| CG-3 Demonstrates social sensitivity and mental engagement in physical activity and game situations. | C3.1 | Designs and executes multiple strategies for the game. |
| | C3.2 | Understands and deals with their and others' emotions, and the thinking process during the game. |
| | C3.3 | Demonstrates calmness and courage in difficult situations, and can calm their teammates. |
| CG-4 Learns to connect physical activity with health, enjoyment, challenge, expression, and social interaction. | C4.1 | Discusses activities that bring personal satisfaction |
| | C4.2 | Identifies diverse cultures with special reference to dance, physical activity, local games and spaces to interact. |
| CG-5 Learns about tournaments at the international, national, state, district and block levels. | C5.1 | Charts the various tournaments at international, national, state, district and block levels. |
| | C5.2 | Describes the participation criteria and rules of the tournament. |
| | C5.3 | Summarises the support structure or organisational structure to participate in tournaments. |
| | C5.4 | Explains the different forms and procedures for participating in tournaments. |

Development of Competencies and Learning Outcomes

Content organisation and learning outcomes for developing competencies in Grade 9.

| Units T: Theory P: Practical | Unit Outline/Key Concepts | Learning Outcomes |
|---|---|---|
| Unit 1 Development of Physical Culture in India 4 Hours (T: 4 hrs) | <ul style="list-style-type: none"> • Definition, Meaning, Aims and Objectives of Physical Education • History and Culture of Physical Education and Sports in India • Introduction to Physical Literacy • Career Prospects | Competencies developed in this unit: C5.1, C5.3, C6.1, C6.2, C4.1, C4.3 Students will be able to: <ul style="list-style-type: none"> • Explain the meaning and evolution of Physical Education. • Appreciate traditional games and their cultural value. • Identify diverse careers in physical education and sports. |
| Unit 2 Health, Fitness and Wellness 6 Hours (T: 2 hrs, P: 4 hrs) | <ul style="list-style-type: none"> • Meaning and Difference Between Health, Physical Fitness and Wellness • Components of Health-related Fitness • Components of Skills-related Fitness • Dimensions of Wellness. • First-Aid, Basic Life Skills (BLS) and CPR | Competencies developed in this unit: C6.1, C6.2, C1.1, C2.1, C2.4 Students will be able to: <ul style="list-style-type: none"> • Differentiate between health, fitness, and wellness. • Identify health-related and skills-related fitness components. • Adopt daily routines promoting hygiene and wellness. • Demonstrate First-Aid and CPR. |
| Unit 3 Sciences and Sports 10 Hours (T: 6 hrs, P: 4 hrs) | <ul style="list-style-type: none"> • Introduction to Body Systems • Skeletal System: Types of Bones, Major Joints, and Functions in Movement • Muscular System: Voluntary and Involuntary Muscles • Introduction to Circulatory and Respiratory Systems during Exercise • Growth and Development | Competencies developed in this unit: C6.1, C6.2, C1.3, C6.3 Students will be able to: <ul style="list-style-type: none"> • Describe body systems involved in movement. • Relate exercise to physiological changes. • Demonstrate understanding of growth and development stages. |
| Unit 4 Technology Integration 4 Hours (T: 1 hrs, P: 3 hrs) | <ul style="list-style-type: none"> • Digital Literacy: Do's and Don'ts, Data Handling and Interpreting Results • Application of Technology in Sports • Wearables in Sports Competitions, Trainings and Projects | Competencies developed in this unit: C1.5, C1.3, C3.1 Students will be able to: <ul style="list-style-type: none"> • Use technology to assess fitness and performance. • Interpret data for performance enhancement. |

| | | |
|---|---|--|
| <p>Unit 5 Sports for All 6 Hours (T: 3 hrs, P: 3 hrs)</p> | <ul style="list-style-type: none"> • Meaning of Inclusiveness in Physical Education and Sports. • Introduction to Disability and Types (intellectual, physical, sensory) • Disability Etiquette and STEP Model • Women’s Participation in Sports • Master Athlete • Community Sports and Khelo India Movement and Fit India | <p>Competencies developed in this unit: C2.3, C2.1, C2.2, C5.1</p> <p>Students will be able to:</p> <ul style="list-style-type: none"> • Describe the concept of inclusivity in sports. • Show sensitivity to disabilities and gender equality. • Participate in community sports programmes. |
| <p>Unit 6 Olympic Movement 6 Hours (T: 2 hrs, P: 4 hrs)</p> | <ul style="list-style-type: none"> • Olympism: Concept and Olympic Values (Excellence, Friendship and Respect) • Olympic Value Education: Joy of Effort, Fair Play, Respect for Others, Pursuit of Excellence, Balance Among Body, Will and Mind • Ancient and Modern Olympics. • Olympics: Symbols, Motto, Flag, Oath, and Anthem | <p>Competencies developed in this unit: C5.1, C2.5, C2.6</p> <p>Students will be able to:</p> <ul style="list-style-type: none"> • Explain the evolution of the Olympic Movement. • Apply Olympic values in daily life and sports. |
| <p>Unit 7 Yoga 14 Hours (T: 3 hrs, P: 11 hrs)</p> | <ul style="list-style-type: none"> • Yoga for Holistic Health and Well-being • Yoga for Health • Adolescent Age and Hormonal Balance • Yoga for Personal Excellence • Memory and Concentration | <p>Competencies developed in this unit: C1.1, C6.2, C2.2, C3.3, C5.2</p> <p>Students will be able to:</p> <ul style="list-style-type: none"> • Demonstrate selected yoga asanas and pranayama. • Understand yoga’s role in holistic health and well-being. |

| | | |
|--|---|--|
| | <ul style="list-style-type: none"> • Willpower and Self-Confidence/ Self-Esteem • Leadership and Responsibility • Creativity and Critical Thinking | <ul style="list-style-type: none"> • Explain yogic practices related to emotional well-being. • Practice yoga and meditation for self-development. • Exhibit improved focus and confidence. |
|--|---|--|

| | | |
|---|---|---|
| <p>Unit 8 Sports</p> <p>40 Hours (P: 40 hrs)</p> | <ul style="list-style-type: none"> • Hockey • Basketball • Judo • Wrestling • Kalaripayattu • Thang Ta • Gatka • Malkambh • Swimming • Archery • Taekwondo • Cricket • Gymnastic • Yogasana | <p>Competencies developed in this unit: C1.1, C1.3 Students will be able to: Demonstrate fundamental skills of the given sports.</p> |
|---|---|---|

Assessment

Assessment in Physical Education and Well-being is continuous, comprehensive, competency-based, and learner-centric. It focuses on assessing not only physical performance but also conceptual understanding, effort, participation, reflection, values, and social behaviour. Assessment practices align with the principles of assessment for learning, assessment as learning, and assessment of learning, as recommended by the NEP 2020.

Formative Assessment

Formative assessment is integrated into daily teaching-learning processes to provide regular feedback and support students' growth.

- **Classroom oral responses and concept checks:** Short question answer sessions, quizzes, and discussions are conducted after lessons to assess the understanding of concepts related to health, fitness, body systems, wellness, and sports ethics.
- **Reflection journal or wellness diary:** Students can maintain a wellness diary to document daily physical activity, sleep patterns, posture, hydration, nutritional habits, and emotional states. This will help them assess their self-awareness, consistency, and reflective abilities.
- **Peer and self-assessment:** After games and physical activity sessions, students can assess themselves and their peers based on their participation, cooperation, effort, fair play, and teamwork. This will encourage the values of responsibility, empathy, and honest reflection among them.
- **Case study and discussion-based assessment:** Students can participate in discussions and case studies, such as — How traditional games promote mental health and social well-being?, allowing assessment of critical thinking, communication skills, and application of concepts among them.

Summative Assessment

Summative assessment evaluates the overall learning outcomes at the end of a unit or term. It can be done in three ways:

- **Pen and paper test:** to assess the conceptual clarity related to definitions, principles, terminology, and factual knowledge, comparison of various practices, its benefits and impact on their holistic health and well-being. Application of practices in real-life situations related to wellness, lifestyle choices, injury prevention or ethical behaviour.
- **Project work:** to assess inquiry, research, creativity, collaboration, application of concepts, interdisciplinary learning, and community-based learning. Projects may include field visits, interviews, surveys, reports, presentations, or digital submissions.
- **Demonstration:** Physical education is about health, fitness, well-being and developing basic and advanced skills in sports and games. Measurement of fitness parameters and demonstration of various skills is an important part of physical education and well-being competencies. Summative assessment of practical demonstration can be done through the rubrics defined in the textbook at the end of each unit.

Textbook

The NCF-SE 2023 aligned new textbook of Physical Education and Well-being for Grade 9 developed by the NCERT.

**Physical Education and Well-being
Grade 9
Session 2026-27**

Max. Marks: 100

**Time: 3:00 Hours
Theory: 20 Marks, Practical: 80 Marks**

Assessment Criteria

| Theory (20 Marks) | Project & Sports File (40 marks) | Practical-Skill Based (40 Marks) |
|---|---|--|
| <p>Every unit contains 2 marks (MCQs/Objective/Short Answer)</p> <p>2 Marks x 8 Units= 16 Marks</p> <p>Viva= 4 Marks</p> | <p>1. Prepare a report of visit to any one of the following:</p> <ul style="list-style-type: none"> • Open tournament/ competition (of any game/sports mentioned in CBSE Games) • Gymnasium/ Fitness Centre • Stadium • Sports Institution <p style="text-align: right;">(5 marks)</p> <p>2. The student will prepare a file on the sports/ game chosen by him/ her covering following aspects:</p> <ul style="list-style-type: none"> • History of the game/sports (200 words) • Terminology of the game/sports (any 5) • Fundamental skills of the game/ sports (any 5) • Rules of the game/ sport (any 5) • Ground/ Court/ Field specification • Common injuries of the game/ sports (any 3) • Indian sports personalities/ awardees of the game/ sports (any 5) • Name of national/ international tournaments/ competitions of the game/ sports (any 3) <p style="text-align: right;">(30 marks)</p> <p>3. Sports Participation</p> <ul style="list-style-type: none"> • Intramural/Extramural <p style="text-align: right;">(5 Marks)</p> | <p>1. Fundamental Skills</p> <ul style="list-style-type: none"> • 5 skills @ 6 marks each = 30 Marks <p>(Any 5 fundamental skills to be demonstrated at the time of practical)</p> <p>2. Advanced Skill</p> <ul style="list-style-type: none"> • 1 skill @ 10 marks = 10 Marks <p>(Any skill to be demonstrated at the time of practical)</p> <p>Note:(of any game/ sports mentioned in CBSE Games)</p> |

Physical Education and Well-being

Grade 9

Session 2026-27

Max. Marks: 100

Time: 3:00 Hours

Theory: 20 Marks, Practical: 80 Marks

Introduction

Physical Education and Well-being is an essential component of holistic education that promotes balanced development of physical, mental, emotional, and social dimensions of learners. In the present era of rapid technological advancement, academic pressure and sedentary lifestyles, the subject plays a critical role in nurturing healthy habits, physical literacy, emotional resilience, and positive social behaviour among students. It prepares learners not only for physical fitness but also for meaningful participation in society as confident, responsible, and ethical individuals.

The scope of Physical Education and Well-being extends beyond sports and physical exercise. It encompasses fitness management, movement skills, emotional regulation, teamwork, leadership, value-based living and holistic well-being. Structured physical activities, games, and reflective practices develop essential life skills, such as self-discipline, perseverance, cooperation, empathy, decision-making, and critical thinking. These skills contribute to the overall well-being, and support lifelong engagement in healthy and active lifestyles.

With increasing societal emphasis on excellence in holistic health, fitness and sports, Physical Education and Well-being addresses contemporary challenges, such as lifestyle-related diseases, mental stress, social inequality, and exclusion. The subject promotes values of fairness, inclusivity, gender equality, respect for diversity, ethical conduct, and social responsibility. It encourages students to develop self-awareness, regulate emotions, and build healthy relationships, thereby contributing to personal and social well-being.

Nature of the Subject

Physical Education and Well-being is a dynamic, experiential, and value-oriented subject that plays a vital role in the holistic development of learners. It recognises movement as a powerful medium for learning and self-expression.

The subject is interdisciplinary, drawing on knowledge from the biological sciences, psychology, sociology, health sciences, technology, and environmental studies. Learners explore how physical activity influences body systems, mental processes, behaviour and social interactions, connecting theory with practice through active participation, observation and reflection.

Physical Education and Well-being is an inclusive and learner-centric subject, catering to diverse abilities, interests, genders, and cultural backgrounds. It promotes equity, accessibility, and participation for all, including children with disabilities and special needs. Through games and sports, students learn ethical behaviour, fair play, discipline, perseverance, humility in success, and grace in defeat, while also developing confidence, self-esteem, and emotional intelligence essential for personal and academic success.

Physical Education serves as a vehicle for character building, providing opportunities for self-regulation, goal setting, critical thinking, and problem-solving in real-life situations. The pedagogy is learner-centric and inclusive, with learning taking place through direct participation, inquiry, discussion, and reflection. Activity based learning, project work, discovery-oriented approaches, and collaborative practices enable students to connect theoretical knowledge with real-life experiences.

Nature of Knowledge in this Subject

Knowledge in Physical Education and Well-being is experiential, applied, interdisciplinary, and transformative. Unlike purely theoretical subjects, collaboration in Physical Education is based on learning through movement, practice, thinking about one's actions, and learning with others. Knowledge is constructed through doing, observing, analysing, and reflecting on physical activity experiences, thereby enabling learners to internalise concepts meaningfully and apply them in real-life contexts.

The knowledge acquired is dynamic and evolving, and is continuously influenced by advancements in sports science, health research, digital technologies, and changing societal needs. The nature of knowledge encompasses four interconnected dimensions:

- **Conceptual Knowledge:** This includes understanding the principles of health, physical fitness, movement, wellness, nutrition, behaviour, and human body systems. Learners gain insights into growth and development, physiological responses to exercise, injury prevention, mental well-being, and the relationship between physical activity and overall health. Conceptual knowledge provides the scientific and theoretical foundation necessary for informed decision-making regarding lifestyle and fitness.

- **Practical Knowledge:** Practical knowledge is developed through hands-on participation and skill acquisition. It involves learning and refining motor skills, sport-specific techniques, movement patterns, game rules and strategies, and safe practices during physical activity. Students also acquire essential life skills, such as First Aid, Basic Life Support (BLS), Cardiopulmonary Resuscitation (CPR), and safety protocols, enabling them to respond responsibly in emergencies and promote a safe supporting environment.

Reflective Knowledge: Reflective knowledge enables learners to evaluate their physical, emotional, and behavioural responses during and after physical activities. Through self-assessment, fitness tracking and reflective journals, students analyse their strengths, limitations, habits, and attitudes. This dimension also fosters awareness of ethical conduct, fair play, inclusivity, respect, discipline and value formation, supporting character development and emotional intelligence.

- **Social Knowledge:** Social knowledge focuses on understanding the role of physical activity like sports in society. Learners explore how sports contribute to nation-building, cultural identity, community engagement, and global harmony. This includes the responsible and meaningful use of leisure time, the promotion of gender equity and equality, the inclusion of persons with disabilities, accountability, affordability, and the appreciation of diversity. Students also learn about teamwork, leadership, cooperation, and citizenship through shared physical experiences.

Knowledge of Physical Education and Well-being empowers learners to develop lifelong healthy behaviours, ethical values, social responsibility, and self-confidence. It supports holistic growth by integrating physical competence with mental awareness, emotional balance, and social sensitivity, preparing students to lead active, healthy, and purposeful lives in a rapidly changing world.

Physical Education and Well-being Grade 9 (Session 2026-27)

Max. Marks: 100

Time: 3:00 Hours

Theory: 20 Marks, Practical: 80 Marks

| Curricular Goals | Competencies | |
|---|--------------|--|
| Learning Standard 1 | | |
| CG-1 Demonstrates a high level of competence in the understanding of movement concepts, strategies, and principles, while engaging and performing in physical activities, including sports and dance. | C1.1 | Exhibits proficiency in all movement and motor skills required to participate and excel in at least one sport, yoga or any other physical activity (team, dual, individual). |
| | C1.2 | Explains the role of rhythmic drills to improve their game. |
| | C1.3 | Exhibits the ability to use complex movement concepts and principles to develop and refine their games or sports skills. |
| | C1.4 | Exhibits and explains the manipulation of space and equipment in the context of a game. |
| | C1.5 | Applies knowledge and understanding of movements, and skills to develop a physical activity plan for themselves, follow a routine and assess independently. |
| CG-2 Exhibits sensitivity and learns to manipulate their personal and social behaviour towards themselves and others. | C2.1 | Reflects upon their and others' behaviour before, during and after the physical activity in the long term. This may include different but related behaviours, including emotional state of mind, physical fitness, fatigue, fair play, biases, and personal interests. |
| | C2.2 | Articulates the importance of emotional and mental support to others, as well as, improving performance and encouraging others to perform by analysing the behaviour of student when someone is emotionally or physically hurt, and how their support may improve others' performance. |
| | C2.3 | Modifies and creates new games and rules that are more inclusive in nature. |
| | C2.4 | Creates and applies safety rules, protocols for physical activity, and visualises how they can be applied outside the field as well. |
| | C2.5 | Demonstrates fairness and responsible behaviour in tough contexts and situations. |
| | C2.6 | Exhibits modesty after an exceptional performance, accepts defeat gracefully and enjoys the game. |
| CG-3 Demonstrates social sensitivity and mental engagement in physical activity and game situations. | C3.1 | Designs and uses multiple strategies in a game and can make new strategic moves in challenging game situations (for example, a student's plan A and B, both failed and strategise a plan C during the game). |
| | C3.2 | Understands and deals with their and others' emotions, and the thinking process during the game. |
| | C3.3 | Demonstrates calmness and courage in difficult situations, and is able to calm their teammates. |
| | C3.4 | Regulates the intensity in different situations. |

| | | |
|--|------|--|
| CG-4 Plans personal physical fitness goals independently and monitors them. | C4.1 | Sets multiple physical activity and fitness goals, such as improving multiple shots or their overall match performance. |
| | C4.2 | Assesses their progress in terms of efforts, processes, and outcomes. |
| | C4.3 | Prepares, plans, and schedules their exercises and warm-ups in consultation with their teacher to get maximum benefits. |
| CG-5 Learns about the value of physical activity for health, enjoyment, challenge, expression, and social interaction. | C5.1 | Illustrates the role of physical education for positive social interaction, while discussing physical activity throughout history and culture. |
| | C5.2 | Examines the role of physical activity in improving self-confidence and self-esteem. |
| | C5.3 | Appreciates the aesthetic appeal of a performance, such as someone's classy straight drive, a beautiful free kick, an effortless smashing of the ball, a well-placed drop shot, or a speedy smash. |
| | C5.4 | Expresses self through dance, gymnastics, or any physical activity. |
| CG-6 Assesses their growth and development. | C6.1 | Examines the role of different factors which affect growth and development, such as heredity, immediate environment, diet, diseases, state of mind and physical activity. |
| | C6.2 | Analyses the relationship of nutrition, physical activity, and mental health with skeletal health, muscles, strength, endurance, flexibility and agility. |
| | C6.3 | Classifies the common injuries of bones and muscles, and describes the protocol for seeking medical help for themselves and others when needed like providing first-aid in such situations. |
| | C6.4 | Outlines and challenges the societal beliefs and taboos associated with different aspects of growth, and development in the adolescent age. |
| CG-7 Learns about tournaments at the international, national, state, district, and block levels. | C7.1 | Charts the various tournaments at international, national, state, district and block levels. |
| | C7.2 | Describes the participation criteria and rules of tournaments. |
| | C7.3 | Summarises the support or organisational structures to participate in tournaments. |
| | C7.4 | Explains the different forms and procedures for participating in tournaments. |

Learning Standard 2

| | | |
|---|------|---|
| CG-1 Demonstrates competence in the understanding | C1.1 | Exhibits all movements and motor skills required to participate and play in at least one sport, yoga or any other physical activity (team, dual, individual). |
|---|------|---|

| | | |
|--|------|--|
| of movement concepts, strategies and principles, while engaging in and performing physical activities, including sports. | C1.2 | Exhibits the ability to use complex movement concepts and principles to develop and refine one's game and sports skills. |
| | C1.3 | Applies knowledge and understanding of movements, and skills to develop their own physical activity plan, follows a routine and assesses independently. |
| CG-2 Exhibits sensitivity and learns to regulate their personal and social behaviour towards themselves and others. | C2.1 | Reflects upon their and others' behaviour before, during, and after the physical activity. This may include different but related behaviours, including emotional state of mind, physical fitness, fatigue, fair play, biases, and personal interests. |
| | C2.2 | Articulates the importance of a team member's support to improve performance in the game, by analysing the behaviour of students when someone is emotionally or physically hurt, and how their support may enhance the performance of others. |
| | C2.3 | Modifies and creates new games and rules that are more inclusive in nature. |
| | C2.4 | Creates and applies safety rules and protocols for physical activity and visualises how they can be applied outside the field as well. |
| | C2.5 | Demonstrates fairness and responsible behaviour in tough contexts and situations. |
| | C2.6 | Exhibits modesty after an exceptional performance, accepts defeat gracefully, and enjoys the game. |
| CG-3 Demonstrates social sensitivity and mental engagement in physical activity and game situations. | C3.1 | Designs and executes multiple strategies for the game. |
| | C3.2 | Understands and deals with their and others' emotions, and the thinking process during the game. |
| | C3.3 | Demonstrates calmness and courage in difficult situations, and can calm their teammates. |
| CG-4 Learns to connect physical activity with health, enjoyment, challenge, expression, and social interaction. | C4.1 | Discusses activities that bring personal satisfaction |
| | C4.2 | Identifies diverse cultures with special reference to dance, physical activity, local games and spaces to interact. |
| CG-5 Learns about tournaments at the international, national, state, district and block levels. | C5.1 | Charts the various tournaments at international, national, state, district and block levels. |
| | C5.2 | Describes the participation criteria and rules of the tournament. |
| | C5.3 | Summarises the support structure or organisational structure to participate in tournaments. |
| | C5.4 | Explains the different forms and procedures for participating in tournaments. |

Development of Competencies and Learning Outcomes

Content organisation and learning outcomes for developing competencies in Grade 9.

| Units T: Theory P: Practical | Unit Outline/Key Concepts | Learning Outcomes |
|---|---|---|
| Unit 1 Development of Physical Culture in India 4 Hours (T: 4 hrs) | <ul style="list-style-type: none"> • Definition, Meaning, Aims and Objectives of Physical Education • History and Culture of Physical Education and Sports in India • Introduction to Physical Literacy • Career Prospects | Competencies developed in this unit: C5.1, C5.3, C6.1, C6.2, C4.1, C4.3 Students will be able to: <ul style="list-style-type: none"> • Explain the meaning and evolution of Physical Education. • Appreciate traditional games and their cultural value. • Identify diverse careers in physical education and sports. |
| Unit 2 Health, Fitness and Wellness 6 Hours (T: 2 hrs, P: 4 hrs) | <ul style="list-style-type: none"> • Meaning and Difference Between Health, Physical Fitness and Wellness • Components of Health-related Fitness • Components of Skills-related Fitness • Dimensions of Wellness. • First-Aid, Basic Life Skills (BLS) and CPR | Competencies developed in this unit: C6.1, C6.2, C1.1, C2.1, C2.4 Students will be able to: <ul style="list-style-type: none"> • Differentiate between health, fitness, and wellness. • Identify health-related and skills-related fitness components. • Adopt daily routines promoting hygiene and wellness. • Demonstrate First-Aid and CPR. |
| Unit 3 Sciences and Sports 10 Hours (T: 6 hrs, P: 4 hrs) | <ul style="list-style-type: none"> • Introduction to Body Systems • Skeletal System: Types of Bones, Major Joints, and Functions in Movement • Muscular System: Voluntary and Involuntary Muscles • Introduction to Circulatory and Respiratory Systems during Exercise • Growth and Development | Competencies developed in this unit: C6.1, C6.2, C1.3, C6.3 Students will be able to: <ul style="list-style-type: none"> • Describe body systems involved in movement. • Relate exercise to physiological changes. • Demonstrate understanding of growth and development stages. |
| Unit 4 Technology Integration 4 Hours (T: 1 hrs, P: 3 hrs) | <ul style="list-style-type: none"> • Digital Literacy: Do's and Don'ts, Data Handling and Interpreting Results • Application of Technology in Sports • Wearables in Sports Competitions, Trainings and Projects | Competencies developed in this unit: C1.5, C1.3, C3.1 Students will be able to: <ul style="list-style-type: none"> • Use technology to assess fitness and performance. • Interpret data for performance enhancement. |

| | | |
|---|---|--|
| <p>Unit 5 Sports for All 6 Hours (T: 3 hrs, P: 3 hrs)</p> | <ul style="list-style-type: none"> • Meaning of Inclusiveness in Physical Education and Sports. • Introduction to Disability and Types (intellectual, physical, sensory) • Disability Etiquette and STEP Model • Women’s Participation in Sports • Master Athlete • Community Sports and Khelo India Movement and Fit India | <p>Competencies developed in this unit: C2.3, C2.1, C2.2, C5.1</p> <p>Students will be able to:</p> <ul style="list-style-type: none"> • Describe the concept of inclusivity in sports. • Show sensitivity to disabilities and gender equality. • Participate in community sports programmes. |
| <p>Unit 6 Olympic Movement 6 Hours (T: 2 hrs, P: 4 hrs)</p> | <ul style="list-style-type: none"> • Olympism: Concept and Olympic Values (Excellence, Friendship and Respect) • Olympic Value Education: Joy of Effort, Fair Play, Respect for Others, Pursuit of Excellence, Balance Among Body, Will and Mind • Ancient and Modern Olympics. • Olympics: Symbols, Motto, Flag, Oath, and Anthem | <p>Competencies developed in this unit: C5.1, C2.5, C2.6</p> <p>Students will be able to:</p> <ul style="list-style-type: none"> • Explain the evolution of the Olympic Movement. • Apply Olympic values in daily life and sports. |
| <p>Unit 7 Yoga 14 Hours (T: 3 hrs, P: 11 hrs)</p> | <ul style="list-style-type: none"> • Yoga for Holistic Health and Well-being • Yoga for Health • Adolescent Age and Hormonal Balance • Yoga for Personal Excellence • Memory and Concentration | <p>Competencies developed in this unit: C1.1, C6.2, C2.2, C3.3, C5.2</p> <p>Students will be able to:</p> <ul style="list-style-type: none"> • Demonstrate selected yoga asanas and pranayama. • Understand yoga’s role in holistic health and well-being. |

| | | |
|--|---|--|
| | <ul style="list-style-type: none"> • Willpower and Self-Confidence/ Self-Esteem • Leadership and Responsibility • Creativity and Critical Thinking | <ul style="list-style-type: none"> • Explain yogic practices related to emotional well-being. • Practice yoga and meditation for self-development. • Exhibit improved focus and confidence. |
|--|---|--|

| | | |
|---|---|---|
| <p>Unit 8 Sports</p> <p>40 Hours (P: 40 hrs)</p> | <ul style="list-style-type: none"> • Hockey • Basketball • Judo • Wrestling • Kalaripayattu • Thang Ta • Gatka • Malkambh • Swimming • Archery • Taekwondo • Cricket • Gymnastic • Yogasana | <p>Competencies developed in this unit: C1.1, C1.3 Students will be able to: Demonstrate fundamental skills of the given sports.</p> |
|---|---|---|

Assessment

Assessment in Physical Education and Well-being is continuous, comprehensive, competency-based, and learner-centric. It focuses on assessing not only physical performance but also conceptual understanding, effort, participation, reflection, values, and social behaviour. Assessment practices align with the principles of assessment for learning, assessment as learning, and assessment of learning, as recommended by the NEP 2020.

Formative Assessment

Formative assessment is integrated into daily teaching-learning processes to provide regular feedback and support students' growth.

- **Classroom oral responses and concept checks:** Short question answer sessions, quizzes, and discussions are conducted after lessons to assess the understanding of concepts related to health, fitness, body systems, wellness, and sports ethics.
- **Reflection journal or wellness diary:** Students can maintain a wellness diary to document daily physical activity, sleep patterns, posture, hydration, nutritional habits, and emotional states. This will help them assess their self-awareness, consistency, and reflective abilities.
- **Peer and self-assessment:** After games and physical activity sessions, students can assess themselves and their peers based on their participation, cooperation, effort, fair play, and teamwork. This will encourage the values of responsibility, empathy, and honest reflection among them.
- **Case study and discussion-based assessment:** Students can participate in discussions and case studies, such as — How traditional games promote mental health and social well-being?, allowing assessment of critical thinking, communication skills, and application of concepts among them.

Summative Assessment

Summative assessment evaluates the overall learning outcomes at the end of a unit or term. It can be done in three ways:

- **Pen and paper test:** to assess the conceptual clarity related to definitions, principles, terminology, and factual knowledge, comparison of various practices, its benefits and impact on their holistic health and well-being. Application of practices in real-life situations related to wellness, lifestyle choices, injury prevention or ethical behaviour.
- **Project work:** to assess inquiry, research, creativity, collaboration, application of concepts, interdisciplinary learning, and community-based learning. Projects may include field visits, interviews, surveys, reports, presentations, or digital submissions.
- **Demonstration:** Physical education is about health, fitness, well-being and developing basic and advanced skills in sports and games. Measurement of fitness parameters and demonstration of various skills is an important part of physical education and well-being competencies. Summative assessment of practical demonstration can be done through the rubrics defined in the textbook at the end of each unit.

Textbook

The NCF-SE 2023 aligned new textbook of Physical Education and Well-being for Grade 9 developed by the NCERT.

**Physical Education and Well-being
Grade 9
Session 2026-27**

Max. Marks: 100

**Time: 3:00 Hours
Theory: 20 Marks, Practical: 80 Marks**

Assessment Criteria

| Theory (20 Marks) | Project & Sports File (40 marks) | Practical-Skill Based (40 Marks) |
|---|---|--|
| <p>Every unit contains 2 marks (MCQs/Objective/Short Answer)</p> <p>2 Marks x 8 Units= 16 Marks</p> <p>Viva= 4 Marks</p> | <p>1. Prepare a report of visit to any one of the following:</p> <ul style="list-style-type: none"> • Open tournament/ competition (of any game/sports mentioned in CBSE Games) • Gymnasium/ Fitness Centre • Stadium • Sports Institution <p style="text-align: right;">(5 marks)</p> <p>2. The student will prepare a file on the sports/ game chosen by him/ her covering following aspects:</p> <ul style="list-style-type: none"> • History of the game/sports (200 words) • Terminology of the game/sports (any 5) • Fundamental skills of the game/ sports (any 5) • Rules of the game/ sport (any 5) • Ground/ Court/ Field specification • Common injuries of the game/ sports (any 3) • Indian sports personalities/ awardees of the game/ sports (any 5) • Name of national/ international tournaments/ competitions of the game/ sports (any 3) <p style="text-align: right;">(30 marks)</p> <p>3. Sports Participation</p> <ul style="list-style-type: none"> • Intramural/Extramural <p style="text-align: right;">(5 Marks)</p> | <p>1. Fundamental Skills</p> <ul style="list-style-type: none"> • 5 skills @ 6 marks each = 30 Marks <p>(Any 5 fundamental skills to be demonstrated at the time of practical)</p> <p>2. Advanced Skill</p> <ul style="list-style-type: none"> • 1 skill @ 10 marks = 10 Marks <p>(Any skill to be demonstrated at the time of practical)</p> <p>Note:(of any game/ sports mentioned in CBSE Games)</p> |

ART EDUCATION CLASS IX (2026-27)

The NCF-SE 2023 broadly classifies the Arts into Visual and Performing Arts (Music, Theatre, and Dance & Movement). It involves innovative and imaginative ways of expression in different forms using a variety of materials and media.

NEP 2020 helps students to utilize various aspects and forms of art and culture as the basis for learning concepts across subjects. A part of the thrust on experiential learning, art-integrated education, embedded in classroom transactions, not only creates joyful learning but also helps in imbibing the Indian ethos through the knowledge of Indian art and culture.

Art in School Education addresses the Goals and Competencies for every student to find diverse ways of persisting and solving problems. We not only create an artwork, but also enjoy the experience of viewing and responding to many forms of cultural expression. When they create artwork together and work collaboratively, they recognize one another's strengths and develop deeper connections with the world around them. Such a process nurtures empathy, appreciation, cooperation, and trust, all of which are fundamental for developing social and human values, such as ahimsa, love, compassion, friendship, and peaceful co-existence. As a common language, the Arts bring people together and lead them to develop acceptance, understanding, and mutual respect

Art classes involve three important processes—making artwork, thinking creatively in the Arts, and appreciating all forms of artistic expression down the ages. This immersive experience of producing art improves cognition, leaving a positive and long-lasting impact on the development of aesthetic sensibilities, expression, imagination, observation, crafting skills, creativity, and students' overall confidence in their own abilities.

Aims

Through Art students should be able to connect with their culture and appreciate the diversity of artistic expressions. For an effective Art Education programme, schools must aim to achieve:

- a. Joy in exploring and creating artwork:** This would mean gaining a variety of aesthetic experiences and deriving joy from all forms of art.
- b. Imagination and creativity:** Acquiring and applying creative thinking and artistic capacities through experimentation and sustained practice in the Arts is at the heart of Art Education.
- c. Empathy and sensitivity:** Meaningful experience in the Arts has great potential to nurture empathy and sensitivity towards the expressions of others.
- d. Understanding of connections with other disciplines:** The Arts teaches

appreciation of beauty in nature and the observation of details and patterns. This approach to the understanding of disciplines makes for aesthetic experiences in themselves.

- e. **Sense of belonging:** Through artistic engagement, students will find connections to their own culture and traditions, as well as learn an appreciation for India's multicultural diversity and knowledge of contemporary artists and art practices.
- f. **Development of Aesthetic Sensibilities:** Students should be able to describe the characteristics of things they find beautiful, do subjective interpretations, assess the aesthetic qualities of artwork based on the commonly accepted criteria in the Arts and expand their 'tastes' by participating in art processes.

Approach to learning different Arts Forms for Practice and Theory

Arts Education emphasizes the process over the product. The NCF-SE 2023 mentions three processes that are integral to the Arts:

- **Thinking Processes** refer to a wide range of cognitive activities in the Arts. It includes generating ideas, understanding the elements of art, inquiring into artistic processes, interpreting artwork, and connecting the Arts with other knowledge and experiences.
- **Making Processes** relate to the execution and production of work, utilizing the active engagement of mind and body to express ideas and emotions. This involves using a variety of creative tools, instruments, materials and techniques.
- **Appreciation Processes** include exposure to and awareness of diverse art forms and cultural practices. This process involves responding to artworks, discussing, describing and assessing aesthetic experiences; considering their social and historical contexts, and developing multiple perspectives along with respect for diverse opinions.

Visual Arts

- Visual Arts learning builds upon the student's knowledge of the elements of art and the principles of design. Through regular practice in creating compositions and other artworks, fundamental concepts, such as perspective, proportion, balance, focus, rhythm and harmony guide students in effectively expressing their ideas and expressions.
- An introduction to art history and basic theories, such as Śaḍāṅga described in ancient treatises like the Citrasūtra, helps students to appreciate the aesthetically rich and continuous heritage of the Indian art traditions.
- Exploration and experimentation with materials, tools and techniques also create opportunities for interdisciplinary linkages.

Music

- Music education includes singing diverse compositions across classical, folk, tribal and contemporary genres, enabling students to experience the richness of India's musical traditions. Students will explore ragas, rhythm patterns and instruments, study the historical evolution of music and its theoretical treatises, and understand how Indian music has gained global recognition through renowned musicians.

Theatre

- Theatre builds on the basic aspects of voice, body language and expression, along with costume, make-up and other backstage elements learned in earlier stages.
- In practice, students explore the basics of direction, lighting and sound, and how these elements shape a scene's emotion and meaning. They experiment with abstract representation, where a single object or gesture can symbolise a broader idea. Through theoretical study, students will learn how theatre developed from the pre-Nāṭyaśāstra period to modern theatre, which uses design, technology, and realistic storytelling techniques. This integration of practice and theory enables learners to think both as artists and storytellers - understanding how every elements, such as light, sound and movement, can express an idea and create an experience that connects people across time.

Dance and Movement

- Dance and movement will be learnt through the application of concepts rooted in texts. Teachers are encouraged to ground instruction in regional dance practices, while also introducing students to dance forms from other regions. Various dance practices, major and other traditions will be learnt with emphasis on stylised body movements, emotional expression and the creative use of hand gestures. They are also introduced to analyse and journal the historical development of dance, taking cultural and geographical contexts into account. The interrelation between dance and other art forms is emphasised, and students are encouraged to integrate interdisciplinary concepts in their creative explorations.

Themes/ Concepts and Learning Outcomes (Suggestive Instructional Hours)

History of Arts (Common Chapter for all four Arts forms)

(30 hours)

| Chapter Outlines/Key Concepts | Learning Outcomes |
|---|--|
| <p>Common History chapter bringing together all art forms</p> <ul style="list-style-type: none"> • Time period covers the prehistoric period to the late 11th century CE. • Tangible and intangible cultural heritage • Storytelling traditions from across India • Chronology of important milestones across all art forms • Ancient texts and literary sources that have guided Indian Arts Traditions • Geographical, socio-cultural and political influences on art practices • Art from around the world that shows parallel development and cross- cultural influences • Continuity of historical art traditions and connections with present times | <ul style="list-style-type: none"> • Students will be able to: Interact with peers, teachers, family members, and artists in their community to know more about Arts practices CG-1, C-1.2. • Create artwork, i.e., inspired by the ideas and processes from art history CG-1, C-1.2. • Identify and discuss the evolution of materials, processes & techniques used in various art forms CG-3, C-3.2. • Trace the historical development of visual arts, theatre, music and dance with examples CG-4, C-4.1. • Identify the continuing ideas, practices, and art traditions mentioned in ancient Indian texts and treatises. CG-4, C-4.1. • Discuss and correlate the geographic, social and cultural linkages across art forms that share a common time period. CG-4, C-4.1. • Explain why they find an artwork or performance relevant to their interests, experience, and present social context. CG-4, C-4.2. |

Visual Arts

| Chapter Outlines/Key Concepts | Learning Outcomes |
|---|--|
| Visual Arts Fundamentals (4 hours / 5 periods) | |
| <p>1.1 Introductory discussion Prior knowledge, and learning and experiences in visual arts</p> | <p>Students will be able to:</p> <ul style="list-style-type: none"> • Journal their interests, observations and experiences through visuals |

| | |
|--|--|
| <p>experiences.</p> <p>1.2 Visual Journal</p> <ul style="list-style-type: none"> • Journaling through drawing and collage • Journalling related to other art forms. <p>1.3 Elements of Visual Arts</p> <p>1.4 Principles of Visual Design</p> <p>1.5 Sketching basics</p> | <p>and notes</p> <p>CG-1, C-1.1.</p> <ul style="list-style-type: none"> • Practice basic Visual Arts processes regularly (e.g., Student spends 10 – 15 minutes every day to create drawing from observation) <p>CG-2, C-2.1.</p> |
| <p>Exploration of Materials and Methods (7.5 hours/ 9 periods)</p> | |
| <p>2.1 Introduction to common materials, mediums and tools in Visual Arts</p> <p>2.2 Proper use, maintenance, and storage of materials and tools</p> <p>2.3 Explore sculptural and hand-crafting traditions in India.</p> <ul style="list-style-type: none"> • Gather information & write about one Indian handcrafting tradition • Create a three-dimensional artwork using its technique, e.g., relief in clay, bamboo crafts, fabric toys, papier-mâché, jute or fibre crafts, etc. <p>2.4 Colour Theory Exercises</p> <ul style="list-style-type: none"> • Colour wheel in different mediums • Colour tints, shades and tones • Complementary and Analogous colours <p>2.5 Perspective</p> <ul style="list-style-type: none"> • Linear perspective • Aerial perspective • Create an artwork using linear and aeria perspective | <p>Students will be able to:</p> <ul style="list-style-type: none"> • Demonstrate familiarity with the use and maintenance of materials and tools used in Visual Arts <p>CG-3, C-3.1.</p> <ul style="list-style-type: none"> • Practice colour exercises using a variety of materials and mediums <p>CG-3, C-3.1.</p> <ul style="list-style-type: none"> • Apply perspective techniques to show spatial depth in their artwork <p>CG-3, C-3.1.</p> <ul style="list-style-type: none"> • Create a three-dimensional artwork using a hand-crafting technique from any part of India e.g., relief in clay, bamboo crafts, fabric toys, papier-mâché, jute or fibre crafts, etc. <p>CG-3, C-3.2.</p> |
| <p>Creative Composition (5 hours/ 6 periods)</p> | |
| <p>3.1 Introduction to Composition</p> <ul style="list-style-type: none"> • Realistic and Abstract representations • Compositional Layout • Importance of iterations <p>3.2 Create a 2D Composition (two</p> | <p>Students will be able to:</p> <ul style="list-style-type: none"> • Create multiple iterations in process of developing their ideas and making artworks <p>CG-3, C-3.1.</p> <ul style="list-style-type: none"> • Compare multiple iterations of one's |

| | |
|--|--|
| <p>options)</p> <ul style="list-style-type: none"> • Create a four-part graphic story or comic strip (in colour) • Thematic painting or collage (choice of genres and themes can vary, such as still life, portrait, landscape, people in indoor or outdoor settings, imaginary composition) | <p>artwork to explain how the arrangement of visual elements conveys different meanings and emotions</p> <p>CG-2, C-2.2.</p> |
| Visual Arts Branches (1.6 hours/ 2 periods) | |
| <p>4.1 Brief introduction to the different branches of Visual Arts:</p> <ul style="list-style-type: none"> • Painting • Sculpture • Printmaking • Applied Art and Design disciplines Heritage crafts | <p>Students will be able to:</p> <ul style="list-style-type: none"> • Expresses their interests in various Visual Arts branches and makes inquiries about visual artists <p>CG-1, C-1.1.</p> |

Music

| Chapter Outlines/Key Concepts | Learning Outcomes |
|--|--|
| Music, Me and Us (5.8 hours/7 periods) | |
| <p>1.1 Active Listening (10 minutes in every class across both grades)</p> <ul style="list-style-type: none"> • Listen to a selection of music across various vidhaas or genres • Discuss the key identifying features of the vidhaa or genre. <p>1.2 Music and personal expression Activity: Create a personal playlist of songs that are in your memory and connect them to the mood and concept of navarasa.</p> <p>1.3 Exploration of themes in folk music</p> <ul style="list-style-type: none"> • Examine the lyrics of folk songs to learn more about a region. • Examine the various themes described in folk music. Activity: Create a piece of music or lyric that expresses a family history, tradition, or practice. • Journal the process of writing the | <p>Students will be able to:</p> <ul style="list-style-type: none"> • Describe a musical composition using general vocabulary of Music CG-3, C-3.2. • Describe how music is an integral part of personal and collective expression. CG-1, C-1.1; CG-2, C-2.1. • Describe the emotions expressed or evoked through music. CG-2, C-2.1. • Describe the thematic content and emotions expressed in folk music. Create and sing a piece of music that expresses a family history, tradition, or practice. CG-2, C-2.1. |

| | |
|---|---|
| <p>lyrics and setting them to music. Activity: Maintain a journal or log that records ideas, observations from listening and creation activities.</p> | |
| The Science of Music (5 hours/6 periods) | |
| <p>2.1 Connections between Physics and Music Revisit how concepts of physics are fundamental to music. Reference to ancient treatises Activity: Experiment with varying the length of a string to manipulate frequency.</p> <p>2.2 Connections between Biology and Music</p> <ul style="list-style-type: none"> • Introduce the anatomy and physiology of the human vocal system. • Activity: Breathing exercises and vocal warm-ups. <p>2.3 Connections between Music and Mathematics</p> <ul style="list-style-type: none"> • Introduce how concepts of pattern-making and Lowest Common Multiple (LCM) are applied in Music. <p>Activity: Recite konnakol patterns demonstrating LCM.</p> | <p>Students will be able to:</p> <ul style="list-style-type: none"> • Describe and demonstrate how sound is produced and manipulated. CG-1, C-1.1; CG-2, C-2.1. • Describe the role of the three main subsystems involved in voice production. CG-1, C-1.1; CG-2, C-2.1. • Recognize ways to care for one's voice and demonstrate vocal warm-ups. CG-1, C-1.1; CG-2, C-2.1. • Study how rhythmic patterns are created from various syllables. CG-1, C-1.1; CG-2, C-2.1. • Demonstrate the concept of LCM in tala. CG-2, C-2.1; CG-3, C-3.1. |
| Ragas and Talas (9 hours/ 10.8 periods) | |
| <p>3.1 Revisiting Basic Elements and Swarasthanas of Indian Classical Music</p> <p>3.2 Raga classification system</p> <ul style="list-style-type: none"> • Raga jaatis (audava, shadava, and sampoorna) • Basic definition of thaata and melakarta systems <p>Activity: Identify the number of notes in a raga.</p> <p>3.3 Hindustani raag — alhaiya bilaval, carnatic raga, and</p> | <p>Students will be able to:</p> <ul style="list-style-type: none"> • Identify and demonstrate the 12 note positions. CG-1, C-1.1; CG-3, C-3.1. • Describe the concepts of raga classification system with examples. CG-3, C-3.1. • Sings the notes of one raga each from Hindustani and Carnatic Music. Sings at least two compositions in a raga of Carnatic and/or Hindustani Music. CG-3, C-3.1 • Explain and demonstrate two talas |

| | |
|---|---|
| <p>shankarabharanam.</p> <p>3.4 Two compositions each in Hindustani and Carnatic Music</p> <p>3.5 Hindustani taal — teentaal, jhaptaal Carnatic taals — aadi, rupaka</p> <p>Activity: Write a piece of music as per the taal cycle. Reflect on the process of writing a lyric and setting it to a taal.</p> | <p>each of Hindustani and Carnatic Music. CG-3, C-3.1.</p> <ul style="list-style-type: none"> • Compare a composition before and after setting it to taal. CG-2, C-2.1, C-2.2; CG-3, C-3.1, C-3.2 |
| <p>Collaborations and Impact of Indian Music on other types of Music around the World (5 hours/ 6 periods)</p> | |
| <p>4.1 Music and migration</p> <ul style="list-style-type: none"> • Introduction to how migration influences music • Examples of music styles that have resulted from migration (e.g., Chutney, UK Bhangra, etc.) <p>Activity: Building a memory box of songs as an archive of family or community memory.</p> <p>4.2 Families of musical instrument with similar features across the world</p> <ul style="list-style-type: none"> • Lute family and Flute family <p>Activity: Examine the similarities and differences between related instruments in terms of their structure and sound.</p> | <p>Students will be able to:</p> <ul style="list-style-type: none"> • Discuss how migration has influenced world and Indian music. CG-4, C-4.1. • Describe the various ways in which musical instruments can be categorized CG-2, C-2.1. • Identify and group musical instruments into similar families. CG-2, C-2.1. |

Theatre

| Chapter Outlines/Key Concepts | Learning Outcomes |
|---|--|
| <p>Create your theatre company, Vision logo team, Research in theatre (5 hours/ 6 periods)</p> | |
| <p>1.1 Creating a theatre company:</p> <ul style="list-style-type: none"> • Team building and collaboration • Vision of the Theatre Team: Creative thinking behind the name and logo, and defining purpose and goals <p>1.2 Research in Theatre</p> <ul style="list-style-type: none"> • Individual or Group Research <p>Activity: Students choose a topic</p> | <p>Students will be able to:</p> <ul style="list-style-type: none"> • Discuss the ideas and processes that interest them in Dramatic Arts. CG-1, C-1.1. • Explore the potential of theatre for a social purpose. Demonstrates empathy and sensitivity in interacting with people. CG-1, C-1.2 • Interact with peers, teachers, family |

| | |
|--|--|
| <p>that interests them in the Dramatic Arts. They engage with concepts and tools related to researching Dramatic Arts in society.</p> <ul style="list-style-type: none"> • Conduct interviews with theatre personnel. • Conduct surveys and field Visits • Visits art galleries and watch different performances (such as melas, activity or cultural centres, auditoriums, museums, etc. • Studies selected literature and apply it to the research topic. | <p>members and artists in their community to know more about the scope of the Dramatic Arts, e.g., enquire about access and locations of auditoriums, performers, types of plays, theatre groups, festivals, etc.</p> <p>CG- 1, C-1.2</p> |
| <p>Lighting and sound, Basic concepts of design, Lights and sound equipment, Background music and sound effects (3.20 hours/ 4 periods)</p> | |
| <p>2.1 Introduction to importance of light and sound in theatre</p> <ul style="list-style-type: none"> • Lighting equipment, such as Parcan, profile, fresnal lens, patch panel, dimmer, etc. Sound equipment like microphones, amplifiers and speakers • Their functional roles in performance environments. <p>Basic concepts of design: Explore how lighting and sound (stage lighting, background music and sound effects) influence mood, meaning, and emotional tone within a scene.</p> | <p>Students will be able to:</p> <ul style="list-style-type: none"> • Identify differences in approaches and techniques of scene work at each step of the process, e.g., explain how the arrangement of various elements convey different meanings and emotions. CG-2, C-2.1. • Experiment with themes and ways of presentation during large collaborative projects targeted towards creating drama. CG-2, C-2.2 • Understand and applies concepts of light, lenses, electricity and sound in theatre. Able to blend the science concepts to enhance the creative output on stage. CG-3, C-3.1 |
| <p>Direction and Acting, Basic techniques and responsibilities of a director, Schools of acting, Facilitating workshops (6 hours/ 7 periods)</p> | |
| <p>3.1 Introduction to styles, techniques, and values related to direction:</p> <ul style="list-style-type: none"> • Visualising a scene and its techniques • Styles and approaches to direction • Schools of acting in Indian and Western traditions • Facilitating workshops | <p>Students will be able to:</p> <ul style="list-style-type: none"> • Experiment with themes and projects targeted towards large collaborative projects targeted towards creating drama. CG-2, C-2.1 • Experiment with rehearsal techniques and run-throughs. CG-2, C-2.1 • Explore one's own abilities in |

| | |
|--|---|
| <ul style="list-style-type: none"> Leadership, collaboration, and taking responsibility in the production process | <p>performance as an individual and in groups. CG-2, C-2.2</p> <ul style="list-style-type: none"> Demonstrate familiarity with the proper use and maintenance of costumes, props, stage equipment used for drama CG-3, C-3.1 Experiment with theatre games, skill building activities and rehearsal techniques CG-3, C-3.1 |
|--|---|

Stage aesthetics Colours and Symbolism in theatre (2.30 hours/ 3 periods)

| | |
|--|---|
| <p>4.1 Symbolism: Exploring various icons, indices and symbols through scene-building activities.</p> <p>4.2 Colours and meaning building: Activities include colour theories in Natyashastra, the impact of colours on stage (sets, props, and costumes and their effects)</p> <p>4.3 Art appreciation: Read different literatures beyond drama, poetry and short stories. Observe various types of drama from classical, folk, modern to build opinions and share thoughts.</p> <p>4.4 Connect with other art forms: Visit art galleries, museums, auditoriums to watch different performances, interview artists from different disciplines, group discussion, etc., to enhance perspective and approach towards art.</p> | <p>Students will be able to:</p> <ul style="list-style-type: none"> Understand abstract representation on stage. Builds simple metaphors and symbol for story concepts. CG-4, C-4.1 Consider multiple viewpoints and interpretations while responding to diverse forms of Indian dramatic arts and cultures presents non-judgemental and contextual views with an awareness of geography and cultural diversity. CG-3, C-3.2 Identify differences in approaches and techniques of scene work at each step of process e.g., explains how the arrangement of various elements convey different meanings and emotions. CG-2, C-2.1 |
|--|---|

Dance and Movement

| Chapter Outlines/Key Concepts | Learning Outcomes |
|---|---|
| Components of Dance (4 hours/ 5 periods) | |
| <p>1.1 Body Geometry: Concepts of saushthava, rekha and roopa</p> <p>1.2 Revisiting rhythms and tempos</p> <p>1.3 Introduction to the four abhinayas</p> <p>1.4 Dance in Cinema Activity: Watch</p> | <p>Students will be able to:</p> <ul style="list-style-type: none"> Describe and demonstrate body alignment (saushtava) while performing dance movements. CG-3, C-3.1 |

| | |
|---|---|
| <p>a dance sequence from a film and write an entry it</p> <p>1.5 Dance Project Activity: Watch a dance performance, and write an entry analyzing your observations of the performance</p> | <ul style="list-style-type: none"> • Apply basic elements, such as footwork, hand gestures, rhythm, tempo and mood in dance sequences. CG-2, C-2.1 • Describe the classifications of dance (nr̥tta and nr̥tya), as well as four abhinayas and their application. CG-3, C-3.1 • Identify the dance form and correlates (nr̥tta and nr̥tya), abhinayas, rasa, and rhythm in the performances. CG-4, C-4.2 • Examines the four abhinayas through the work of important personalities across diverse art forms. CG-4, C-4.1 |
|---|---|

Dance as Visual Storytelling (4 hours/ 5 periods)

| | |
|--|---|
| <p>2.1 Abhinaya in various dance traditions</p> <p>2.2 Performing abhinaya Activity: Create performative situations or phrases applying the different abhinayas.</p> | <p>Students will be able to:</p> <ul style="list-style-type: none"> • Discuss and compare the different types of abhinaya, and incorporate these into the creative practice. CG-3, C-3.2 • Perform movement sequences with different kinds of music and narration, and compare the experiences. CG-2, C-2.2 |
|--|---|

Cultural Connections through Dance (7.30 hours/ 9 periods)

| | |
|--|--|
| <p>3.1 Indian dance cultures Activity: Learn and perform the local and regional dance forms.</p> <p>3.2 Career journeys of artists Activity: Carry out a podcast and interview a performer, or visit a related institution.</p> <p>3.3 Comparative analysis project on dance stories in India and Southeast Asia Create and perform a short dance performance combining element of the Southeast Asian dance forms, and discuss its similarities and differences</p> | <p>Students will be able to:</p> <ul style="list-style-type: none"> • Interact with art professionals and find what interests them in Dance. CG-1, C-1.2 • Create a dance sequence inspired by the elements of diverse Indian and global dance forms. CG-3, C-3.1, C-3.2 |
|--|--|

| Dance: A Journey from Concept to Creation (5 hours/ 6 periods) | |
|--|---|
| <p>4.1 Choreography — rhythm and tempo, distance and space</p> <ul style="list-style-type: none"> • Create and perform a short choreography incorporating concepts of space, direction, rhythm, and abhinaya. <p>4.2 Discuss the physical, mental and emotional well-being through movement</p> | <p>Students will be able to:</p> <ul style="list-style-type: none"> • Contribute ideas and reflect the collaborative process of dance choreographies. CG-2, C-2.2 • Creatively use space and directions in solo and group choreographies. CG-3, C-3.1 |

Pedagogy or Instructional Methods

Arts Education not only develops skills and craft of making and performance, but develops broader arts appreciation and creative thinking capacities. Thus, art classes foster peer learning, encourage students to express themselves freely, exchange ideas, explore techniques in their work, and develop an appreciation of the diversity of art and aesthetics in India and the world.

Experiential Learning

The NCF-SE 2023 emphasises that art must be learnt through performing or making of artwork or performances. Rather than relying merely on explanation, theoretical concepts are learnt through activities, and students must be encouraged to apply them in their artistic expression. Students may be asked to demonstrate their creations and discuss their learning and reflections in groups. Encouraged to reflect on their experiences through regular journaling.

Collaboration

Learning is encouraged through group activities and discussions with peers. Classroom discussions of concepts, artworks and performances, and student work allow them to gain exposure to a variety of perspectives and aesthetics, and to learn to appreciate and accommodate diverse perspectives.

Interdisciplinarity

Activities have been designed by keeping in mind the meaningful connections of techniques, skills, materials across art forms and other disciplines. These activities promote learners' understanding of the linkages between the visual and performing arts, as well as other disciplines, such as Languages, Social Sciences, Sciences and Physical Education.

Emphasis on Local Culture and Resources

Teachers are encouraged to make use of local resources and local cultures in their teaching. Activities may be modified based on available resources, space

and infrastructure. While it is expected that students gain exposure to art and culture from across India and the world, it is essential that they are first made familiar with the art and traditions of their region. Workshops with local artists may provide exposure to new experiences and professions within the arts.

Effective Use of Teaching Learning Materials

Teachers are encouraged to show students relevant artworks and digital material, such as videos, photographs and audio recordings, and conduct classroom discussions and allow time for reflection. Visits to museums, heritage sites, performances, melas, etc., help students learn through exposure to art accessible in their regions.

Inclusivity

Teachers must encourage the participation of and collaboration among all students, regardless of gender, ability, or social background. Students with disabilities must be given equal opportunities and access to participate in all art activities and discussions. Teachers could modify activities to make them inclusive for all students in a class and should focus on what students with disabilities can do independently or with some guidance to empower them.

| Visual Arts |
|--|
| <p>Discussions</p> <ul style="list-style-type: none"> • Large group discussions while introducing new concepts • Small group discussions for brainstorming and project work • Individual conversations while making an artwork • Practical activities • Exercises for core skills • Regular sketching and journaling • Theme-based projects that focus on making, completing and presenting artwork • Beyond the textbook: Alternatives and adaptations of textbook activities that can achieve competencies • Exposure visits or workshops • Visits to museums, art institutions, local art centres, melas, etc. • Interactive workshops with invited artists |
| Music |
| <p>The five aspects in Music training incorporates:</p> <ul style="list-style-type: none"> • Listening: Introduces the learner to the different forms of music, styles of rendition, and skills of musicians. Provides exposure to live Music programmes or concerts through multiple media platforms. • Responding: Imbibing different styles of singing, understanding the emotional content, copying, and also creating simultaneously is an essential tenet. • Creating: Tunes, lyrics and rendering in varied styles by combining vocal and |

instrumental Music is an important aspect. This collaboration has created many styles of compositions.

- Presentation Skills: The setting of a stage, rapport with the audience, technical settings and adjustments are essential.
- Understanding the linkages of music to dance, drama, language, and also the tangible objects like heritage monuments, drawings and paintings.

Theatre

Group Activities

- Teamwork and leadership skills in planning
- Creative outputs and goals to be presented

Individual work

- Exercises for core skills
- Self-analysis and focus on individual interests
- Presentations of project works and opinions
- Exploratory activities of individual possibilities

Class Activities

- Visits to performances, meeting the cast and crew backstage
- Workshops with experienced technicians and artists
- In-class work and spontaneous project presentations
- Out of class work — meeting people, interviews, surveys

Dance and Movement

Threefold Aspect of Dance Education:

1. Seekhya (Learning or Training Methods)

- Textbook instructions are to be followed by the teacher, and theory will be taught from the textbook. Thus, the written material could be taught by any art teacher.
- Lessons modules to be provided with videos on DTLM.
- The basic pedagogy will focus on imparting the basics movements aided by concepts from dance treatises.
- Students may be encouraged to apply concepts with their imagination and creativity. For example, hand gestures can be explored with the learner building their vocabulary and language using the concept of hand gestures as a tool of communication.
- Attending workshops and lecture demonstrations will also be a component of the pedagogy.

2. Dekhya (Watching, Observing)

- The students will be encouraged to attend performances by maestros, and established exponents of Indian and global dance forms.
- Observe ritual and community dances that are part of the local culture of the region.

3. Parkhya (Contemplation, Discussion, Writing)

- Students are encouraged to research, journal and foster writing on dance.

Self-review of their dance and movement, and speaking on their personal experiences through dance will be a part of the pedagogy.

Art Education
Class IX (2026-27)
Theory

Time allowed: 2:00 hours

Maximum Marks: 40

| S. No. | Themes/ Concepts | Marks |
|---------------|---|--------------|
| A. | History of Arts | 20 Marks |
| B. | 1. Visual Arts | 4 Marks |
| | 2. Music | 4 Marks |
| | 3. Theatre | 4 Marks |
| | 4. Dance | 4 Marks |
| C. | Analytical note on an unseen image from the viewpoint of all art forms.(Integrated) | 4 Marks |

Practical
Visual Arts

Time allowed: 3 hours

Maximum Marks: 60

| | | |
|-----------|--|-----------------|
| A. | External Assessment | 40 Marks |
| 1. | Composition layout | 10 Marks |
| 2. | Handling of colour | 10 Marks |
| 3. | Colour value/ hatching- cross hatching | 5 Marks |
| 4. | Overall | 5 Marks |
| 5. | Viva | 10 Marks |
| B. | Internal Assessment | 20 Marks |
| | • School event (Participation of student throughout the academic session) | 5 Marks |
| | • Project report | 5 Marks |
| | • Formative assessment (Average of Two best throughout the academic session) | 10 Marks |

Music

Time allowed: 10 minutes per student

Maximum Marks: 60

| | | |
|-----------|--|-----------------|
| A. | External Assessment | 40 Marks |
| 1. | Presentation of the choice Raga of the candidate. | 10 Marks |
| 2. | Presentation of a composition in a classical/ tribal/ folk/ contemporary genre etc. | 5 Marks |
| 3. | Tala on presentation on hand demonstrating beats and matras and their relation with mathematical calculations. | 5 Marks |

| | | |
|-------------------------------|---|----------|
| 4. | Overall performance | 10 Marks |
| 5. | Viva choice (Related to the knowledge of Rags, Talas, Forms or genre/ instruments in terms of sound and their structure. | 10 Marks |
| B. Internal Assessment | | |
| | • School event (Participation of student throughout the academic session) | 5 Marks |
| | • Project report | 5 Marks |
| | • Formative assessment (Average of Two best throughout the academic session) | 10 Marks |

Theatre

Time allowed: 10 minutes per student

Maximum Marks: 60

| | | |
|-------------------------------|--|-----------------|
| A. External Assessment | | 40 Marks |
| 1. | Technique (voice, body language, expression) | 10 Marks |
| 2. | Concept/ idea/ story | 5 Marks |
| 3. | Confidence and creativity | 5 Marks |
| 4. | Application of concept learnt from the book | 10 Marks |
| 5. | Viva | 10 Marks |
| B. Internal Assessment | | |
| | • School event (Participation of student throughout the academic session) | 5 Marks |
| | • Project report | 5 Marks |
| | • Formative assessment (Average of Two best throughout the academic session) | 10 Marks |

Dance

Time allowed: 10 minutes per student

Maximum Marks: 60

| | | |
|-------------------------------|--|-----------------|
| A. External Assessment | | 40 Marks |
| 1. | Presentation of Abhinaya | 10 Marks |
| 2. | Application of basic dance elements (Hand Movements, Body Movement, Foot Movement.) Based on the classical beats | 5 Marks |
| 3. | Performance of different rhythm and tempos. | 5 Marks |

| | | |
|-----------|--|-----------------|
| 4. | Presentation of any classical/ tribal/ folk/ contemporary gene etc. | 10 Marks |
| 5. | Viva (Related to the knowledge of hand movement, Pad Sanchalan, Abhinaya in different types of dance) | 10 Marks |
| | | |
| B. | Internal Assessment | 20 Marks |
| | <ul style="list-style-type: none"> • School event (Participation of student throughout the academic session) | 5 Marks |
| | <ul style="list-style-type: none"> • Project report | 5 Marks |
| | <ul style="list-style-type: none"> • Formative assessment (Average of Two best throughout the academic session) | 10 Marks |

Note: The Theory paper will carry 40 marks and the Practical paper will carry 60 marks. The Practical marks will be calculated as the average of all four sections, i.e., Visual Arts, Music, Theatre, and Dance.

ENGLISH

Class IX (2026-27)

Introduction

At the secondary stage, language learning strengthens the learners' abilities to use language meaningfully for comprehension, expression, interpretation, and critical engagement with texts. Pedagogical processes emphasise dialogic reading, reflective writing, listening, and speaking activities, and contextual use of language through discussion, interpretation, and creative expression. Assessment focuses on understanding, interpretation, communicative clarity, articulation of ideas, and the ability to analyse and respond to texts in multiple modes, rather than only on recall-based written responses.

As per NCF-SE 2023, language education at the Secondary Stage must specifically aim to achieve:

- (a) **Oracy and literacy:** Oracy and literacy are fundamental to school education.
 - Attaining oracy means students develop fluency in expression and understanding of spoken language.
 - Literacy means that all students demonstrate fluent and critical reading, writing, and comprehension capacities in the language.
- (b) **Effective communication skills:** Students may develop their language capacities to think critically, identify real-world problems, analyse them, make rational arguments, work out solutions and communicate well in a variety of situations for effective democratic, social, and cultural participation.
- (c) **Literary and creative capacities:** Language teaching in schools must aim at building capacities in students towards an appreciation of the literary aspects of language. It may also allow for an exploration of—how to be creative and imaginative in their spoken and written expressions across cultures.
- (d) **Appreciation and engagement in culture:** Learning a language is learning a culture. Thus, language plays an important role in the immersion and participation in culture. Students must be allowed to understand and appreciate the rich linguistic cultures of India.
- (f) **Linkages with the Indian Knowledge System:** Along with the development of skills and competence, other aspects such as emotional intelligence, social feeling, national pride, connections of art, social concerns, and natural science are addressed through content, context and pedagogy with the focus on fundamentals of literature and life (critical thinking), such as emotion, perception, feeling, sound, language, thought, memory, metaphor, aesthetics, environment, self, society, culture, civilisation, etc.

Language Learning Approach

Experiential, activity and discussion-based approaches are recommended to promote the culture of self-learning and reduce dependence on the teacher. The teaching of language will be enhanced through innovative and experiential methods. Thus, the teaching of language will also be based on the experiential-learning pedagogy. The shift requires that students' contexts and experiences become part of the pedagogical processes.

Experiential learning includes any type of activity that comprises learning by doing, i.e., experimenting, exploring, sharing personal narratives, observing, cooperative learning, and above all, self-learning and self-assessment. Students need to have mastery in the 21st century skills, such as effective communication, critical thinking, creativity, collaboration, etc.

There are diverse learning situations and contexts in India. Language education plays a crucial role in keeping students rooted to their country, as it allows individuals to connect with their culture, heritage and society.

Learning Standards

Learning standards enable teachers to plan their content, pedagogy, and assessment towards achieving specific competencies. These must be seen as enabling guidelines for teachers and school leaders, not as constraining demands on them. By the end of the secondary stage, we would expect every student must have gained the whole range of skills and competencies. It is at this stage that using the language of students turns out to be more productive. Students use language to interpret, understand, address issues, and gain knowledge that will help them to become autonomous learners.

As per NCF-SE 2023, students will develop linguistic proficiency for academic use in R1 and R2 by the end of the secondary stage ensuring that a higher level of familiarity, understanding, and interpretation of literature is achieved.

Curricular Goals and Competencies-Secondary Stage

Curricular Goals (CGs) are specific statements derived from the broader Aims of Education that give clear direction to curriculum development and implementation. Competencies are the specific, observable, and systematically assessable learning achievements that students must attain by the end of the stage.

Language R1

| Curricular Goal (CG) | Competency (C) |
|--|--|
| CG-1: Uses language for effective communication through writing various forms (essays, letters, articles, discussions, interviews, public speeches) and for new media (email, audio, and visual material). | <p>C-1.1: Uses language appropriate to social context, expresses agreement and disagreement with reasons, and arrives at conclusions through discussion and debate.</p> <p>C-1.2: Writes in different styles (narrative, descriptive, expository, persuasive) from their own experiences and experiences of others.</p> <p>C-1.3: Writes for real-life situations (invitations, speeches, condolence messages, notices, creative slogans, advertisements) and for school newsletter/magazine/journal.</p> <p>C-1.4: Scripts to inform and communicate ideas effectively with the use of technology.</p> |
| CG-2: Develops an appreciation of the aesthetics in different genres (humour, suspense, tragedy) through analysis of style (narrative, descriptive, expository, persuasive) and employs these elements in their writing. | <p>C-2.1: Describes characteristics of works of literature from different time periods (such as early, medieval, contemporary).</p> <p>C-2.2: Analyses a literary text by close reading, critiquing form and style, and interpreting possible meanings.</p> <p>C-2.3: Composes literary texts by using appropriate literary devices.</p> |
| CG-3: Uses language to develop reasoning and argumentation skills by engaging with a variety of audio and written material. | <p>C-3.1: Analyses and evaluates the different audio and written material.</p> <p>C-3.2: Argues with proper rationale by carefully evaluating premises.</p> |
| CG-4: Appreciates literary and cultural heritage in and related to the language and the richness of Indian languages. | <p>C-4.1: Recognises the multilingual nature of Indian society and richness of its literary work through reading texts and watching content of different genres.</p> <p>C-4.2: Appreciates the richness of culture and heritage in the different works of regional language literature and their connections.</p> <p>C-4.3: Shows an understanding of the role of language in the formation of our identities and culture.</p> <p>C-4.4: Demonstrates a basic knowledge of the commonalities among some of the major Indian languages, such as their common phonetic and scientifically arranged alphabets and scripts, common grammatical structures, origins and</p> |

| Curricular Goal (CG) | Competency (C) |
|----------------------|--|
| | <p>sources of vocabularies from Sanskrit and other classical languages.</p> <p>C-4.5: Demonstrates a basic knowledge of which languages are spoken in which geographical areas, a sense of the nature and structure of tribal languages, and becomes familiar with a few useful words and phrases and works of literature from a few Indian languages from across the country.</p> |

Language R2

| Curricular Goal (CG) | Competency (C) |
|--|---|
| <p>CG-1: Uses language for effective communication through various oral activities (discussions, interviews, public speeches) and writing activities (essays, letters, articles), including new media (email, audio, and visual material).</p> | <p>C-1.1: Uses language appropriate to social context, expresses agreement and disagreement with reasons, and arrives at conclusions through discussion and debate.</p> <p>C-1.2: Writes in different styles (narrative, descriptive, expository, persuasive) from their own experiences and experiences of others.</p> <p>C-1.3: Writes for real-life situations (invitations, speeches, condolence messages, notices, creative slogans, advertisements) and for school newsletter/magazine/journal.</p> <p>C-1.4: Scripts to inform and communicate ideas effectively with the use of technology.</p> |
| <p>CG-2: Uses language to develop reasoning and argumentation skills by engaging with a variety of audio and written material.</p> | <p>C-2.1: Analyses and evaluates different audio and written material.</p> <p>C-2.2: Argues with proper rationale by carefully evaluating premises.</p> |
| <p>CG-3: Develops an appreciation of the aesthetics in different genres (humour, suspense, tragedy) through an analysis of style (narrative, descriptive, expository, persuasive) and employs these elements in their writing.</p> | <p>C-3.1: Describes characteristics of works of literature from different time periods (such as early, medieval, contemporary).</p> <p>C-3.2: Analyses a literary text by close reading, critiquing form and style, and interpreting possible meanings.</p> <p>C-3.3: Composes literary texts using appropriate literary devices.</p> |

FOCUS AREAS OF THE SYLLABUS

The syllabus aims to develop students' ability to use language effectively for communication, reasoning and creative expression. The curriculum focuses on strengthening Listening, Speaking, Reading and Writing skills while fostering literary appreciation and critical thinking. Students engage with a variety of texts and activities that promote analytical thinking, creativity, collaboration and real-life application of language skills.

Reading

By the end of the secondary stage, students should be able to:

- Read and comprehend a variety of literary and non-literary texts with understanding.
- Identify main ideas, supporting details and key information in written texts.
- Analyse, interpret and evaluate ideas presented in different texts.
- Distinguish between facts and opinions and identify cause–effect relationships.
- Infer meanings and draw conclusions from textual evidence.
- Understand the author's perspective, tone and style of writing.
- Interpret information presented in different forms such as diagrams, charts and tables.
- Connect ideas from the text with personal experiences and social contexts.
- Develop critical reading skills through close reading and discussion.
- Read independently and engage with texts from diverse cultures and contexts.

Writing

By the end of the secondary stage, students should be able to

- Write clearly and coherently using appropriate grammar, vocabulary and organisation.
- Write in different styles such as narrative, descriptive, expository and persuasive.
- Present ideas with a clear beginning, middle and conclusion.
- Describe experiences, events and observations in a logical manner.
- Express opinions and viewpoints with appropriate reasoning and examples.
- Write for real-life purposes such as notices, invitations, advertisements, speeches and messages.
- Gather ideas from different sources and organise them effectively in writing.
- Write reports, articles and pieces for school magazines, newsletters and journals.
- Use technology and digital tools to present ideas through written and visual formats.
- Review, edit and improve written work through feedback and self-assessment.

Listening & Speaking

Listening

By the end of the secondary stage, students should be able to

- Listen attentively to conversations, discussions and audio material.
- Identify the main ideas and important details in spoken texts.
- Analyse and interpret information presented through speeches, discussions and media sources.
- Distinguish between key points and supporting information.
- Understand instructions, explanations and viewpoints expressed by others.
- Note important details and organise information appropriately.

Speaking

By the end of the secondary stage, students should be able to

- Express ideas clearly and confidently in different situations.
- Present opinions, viewpoints and arguments with logical reasoning.
- Participate actively in discussions, debates and conversations.
- Communicate effectively in formal and informal contexts.
- Present ideas through speeches, presentations and oral reports.
- Respond appropriately to questions and viewpoints of others.
- Interact respectfully with others during discussions and collaborative activities.

Structures (Grammar) & Vocabulary

By the end of the secondary stage, students should be able to

- use the **sequence of tenses** correctly in different contexts of communication.
- identify and apply **modal auxiliaries** to express ability, obligation, permission, possibility, and advice.
- transform and use **reported speech** in extended texts including statements, questions, commands, and requests.
- construct sentences using **Conditional Clauses (Type 1)** to express real and possible situations.
- apply the rules of **subject–verb concord** to ensure grammatical accuracy in sentences.
- use appropriate **determiners** to provide clarity and precision in communication.
- identify and construct **clauses**, including **noun clauses** and **relative clauses**, to create complex and meaningful sentences.
- expand vocabulary through contextual reading and writing;
- understand meanings of unfamiliar words through context and reference tools such as dictionaries;
- use appropriate words and expressions to communicate ideas clearly;
- apply vocabulary effectively in speaking and writing tasks.

Grammar and vocabulary learning will be reinforced through editing tasks, sentence transformation, contextual exercises and communicative activities to promote accuracy and fluency in language use.

Literature — Prose & Poetry

By the end of the course, students should be able to:

- Read and appreciate a variety of literary texts from different genres.
- Analyse characters, themes and ideas presented in literary works.
- Interpret events, conflicts and relationships in stories and poems.
- Recognise the influence of context, culture and background on literary texts.
- Identify literary devices such as simile, metaphor, imagery, repetition and symbolism.
- Interpret meanings beyond the literal level through critical reading.
- Evaluate characters' actions and motivations.
- Express personal responses and interpretations through discussion and creative activities.
- Develop an appreciation of the aesthetic and cultural aspects of literature.

Pedagogy of Language

Pedagogy, at the secondary stage, should take into consideration the knowledge and capacities that students will bring from the previous stages of schooling. The pedagogy may encourage more self-study and exploration with a focus on becoming fluent in the methods of inquiry specific to the Curricular Area. At this stage, students can be reasonably expected to become independent learners and the pedagogy in the classroom may reflect this expectation.

Classroom interactions may be a judicious mix of more direct instruction from the teacher with discussion, seminars for discussion, exploration and discovery, and opportunities for students to prepare individual and group projects and present key concepts of the discipline.

Depending on the matter of study, context, and stage of the student, these effective pedagogical approaches would be of a wide range, including pedagogy that is more experiential, integrated, inquiry-driven, discovery-oriented, discussion-based, project-based, arts-based, sports-based, and activity-based. Effective pedagogy, therefore, encourages conceptual understanding, active discovery, questioning and debating, and independent learning. It gives serious consideration to student experiences and student voices, acknowledges and accommodates student diversity, builds on students' previous knowledge, uses a range of teaching techniques, and gives timely feedback on the work done. Classroom processes must encourage active learning with an emphasis on dialogue and building relationships based on mutual respect.

At this stage, the following may become part of the pedagogical process.

a) **Oral presentations:**

- I. Students must be given opportunities for sharing their ideas freely and listening to others' points of view. They must also ask questions, argue for their own views, and accept others' views with proper justification.
- II. Students must be taught focused dialogue and conversation which require organising their thoughts for better clarity, the art of raising relevant questions, brainstorming, and thinking aloud, active participation, and skills of literary appreciation.
- III. Teachers must use methods, such as role play, group discussion, debate, open house dialogue, and interviews to allow students to ask questions and learn to respond impromptu. Club-based activities, assembly gatherings, and celebrations in schools can be used as platforms to practise these methods and may not be seen as a separate exercise.
- IV. Teachers must also find ways to teach students how to work on their listening skills (by paying attention to details and summarising) and use the same in day-to-day life.

b) **Developing reading skills:**

- I. **Literary language skills:** Students can be encouraged to participate in group activities in critically analysing a literary text in the class and participate in the activities of the school literature club, poetry house, and fiction-reading groups.
- II. **Critical reading skills:** The teacher may focus on enabling students to make meaning of a variety of texts, move from initial impressions to a closer reading of the text by asking questions related to the effect of words and ideas expressed, and how the effect of the language used in a text is working for specific purposes.
- III. **Exposure to reading multicultural texts:** Activities such as the comparison of literary works of two different writers can be done effectively by inquiring into the author's voice, cultural background, and context of the work, and talking about other similar works in the genre. Projects, plays, folk music performances, and posters are important ways in which students in this stage can be introduced to texts from a different era. Multicultural texts may be available in libraries for students to read in their free time.

c) **Developing writing skills:**

- I. **Functional language writing skills:** Students may be given enough opportunity to practise writing reports, essays, notes, applications, letters to editors, advertisements, and notices. They can also be encouraged to write in magazines, newsletters, newspapers, and blogs.

II. **Literary language writing skills:**

- i. Students must be guided towards independent and creative writing in this stage. They must be taught capacities for analysing literature and connecting it to its historical and socio-economical aspects rather than reading it in isolation, enabling the writing of a critical review.
- ii. Teachers must ensure students practise writing poems, stories, or plays with literary devices (e.g., similes, metaphors, hyperbole, irony, puns, and oxymorons).
- iii. Teaching them to identify voice and style of a writer taking cues from the material they read will help them find their own voice.

Assessment

In alignment with NCF-SE 2023, assessment moves beyond measuring recall to evaluating students' ability to interpret ideas, communicate effectively, think critically, and engage meaningfully with texts and contexts. Assessments should be based on observations, portfolios, and projects and should not just focus on capacities and skills, but also values and dispositions.

Assessments need to be visualised as an ongoing process which teachers integrate within the teaching-learning process using formal and informal ways to elicit reliable evidence about student learning. Assessment may not become an intimidating process that involves the labelling and segregation of students.

The 'assessment culture' must change, so that assessment is conducted increasingly as learning and for learning. There must also be periodic assessment of learning to ensure readiness for the next phase of learning and to arrange suitable support for students when this readiness is not achieved.

Assessment should emphasize a balanced approach integrating three dimensions:
Assessment of Learning; Assessment for Learning; Assessment as Learning

Assessments could be formative or summative, and both are important for improving teaching and learning.

a) **Formative Assessment**

- I. Formative assessments at secondary stage will continue to be competency-based, covering all dimensions of learning. Therefore, various formative assessment techniques, such as projects, debates, presentations, discussions, experiments, investigations, role plays, journals, and portfolios, should be used to assess learning.
- II. Regular assessments comprising MCQs and constructed responses (e.g., short answer and long answer), with the aim to test conceptual understanding and higher-order capacities rather than merely rote learning.
- III. Classroom and Self-assessment will play a key role in student learning at this stage.

- IV. Assessments can be designed using case-based questions, simulations, and essay-type questions to enable the assessment of competencies in order to continually replan and revise the teaching-learning process.

b) **Summative Assessment**

Summative examinations, including certification examinations, continue to be relevant as they serve as a necessary test to understand students' achievement of competencies and learning standards.

- I. At the end of each year (or term), there will be a comprehensive summative assessment, which in relevant cases, would be the Board examinations.
- II. Assessment may measure the achievement of competencies and learning standards leading to the attainment of Curricular Goals. The connection between the competencies or Learning Outcomes and the assessment should be clear and precise.
- III. Appropriate forms of assessments may be chosen in alignment with the competencies and learning standards to be assessed.
- IV. Assessments should be constructive, developmental, and learning focused.

Forms of Assessment

There are several forms of assessment that can be used across both formative and summative assessments.

(a) **Written Tests:** Forms of written tests include:

- I. **Objective Type Questions:** These include Multiple Choice Questions (MCQs), filling in blanks, matching, sorting lists based on select criteria, picking the odd one out, labelling a diagram, solving a crossword, unscrambling a word, solving riddles and word grids that require a very short or one-word answer.
- II. **Constructed Response Questions:** These are questions that require students to frame and write answers. They can be close ended (requiring one correct and short answer) or open-ended (requiring a short or long essay with multiple correct/alternate answers).
It is important to have clear and detailed scoring guides/marketing schemes for such questions to avoid subjectivity in assessment.
- III. **Graphic Organisers:** These visual representations of ideas and concepts help students organise their learning and assimilate new knowledge.

(b) **Oral Tests:** The most common forms are reading aloud, responding to questions, recitation, and debates and discussions. Other forms, include group discussions, presentations, and extempore talks.

- I. **Reading Aloud:** Reading assessments could include reading aloud a passage, a poem, or any other form of writing. Word recognition, fluency,

and voice modulation skills could be assessed along with comprehension by asking students to summarise or talk about what they have read.

- II. **Listening and Responding:** Students listen to a text and respond either orally or on a worksheet.
- III. **Recitation:** This helps the teacher assess the spoken language with a specific focus on pronunciation, intonation and comprehension by observing students' expressions and actions.
- IV. **Debates and Discussions:** Students' fluency of language as well as proficiency in making strong arguments using knowledge and reasoning to persuade and convince the audience can be assessed while also developing an ability to understand and respect others' viewpoints and opinions. Teachers can also include other parameters, such as diction department, ability to take criticism positively, and manage their emotions and body language during public speaking. Sharing parameters before setting the task helps students focus on developing these skills which serves as good learning opportunities as well.

Practical Tests

These require students to demonstrate specific skills and applications of their new learning. These include :

- I. **Projects:** Projects are longer, structured activities completed by individual students or groups of students that result in a product. For example, a model, a substantial report, or a collection of artefacts. While doing projects, students investigate, explore, and respond to complex questions, real-world challenges, and problems. Projects help assess collaboration, communication, perseverance, creativity, and problem solving along with assessing subject-specific knowledge and skills.
- II. **Portfolios:** A student portfolio is a purposeful collection of student work that tells a story about a student's efforts, progress, and achievement in one or more subjects over a period of time. It could be a collection of the student's day-to-day work or a selection of the student's best pieces of work. Portfolios may include writing samples, laboratory reports, journals, artwork, short surveys and research papers, projects, photos, worksheets, tests and map work, Teacher's qualitative comments on the students' work, peer feedback, and the students' own reflections on their learnings.

It becomes a cumulative record of performance from which emerges a clear picture of what students know, can do and how they have progressed over the period.

III. Multiple Assessment

These include a range of activities like quizzes, worksheets, oral presentations, class discussions, etc.

IV. Periodic Pen and Paper Assessment

Prescribed Textbook- Kaveri: Textbook of English for Grade 9

The textbook has been developed based on common curricular goals rather than rigid differentiation between R1 & R2. The textbook content, learning outcomes, and assessment remain aligned with the common competency framework envisaged for R1 and R2 at the secondary stage, and therefore, the same textbooks can be transacted flexibly in accordance with the learner profile and institutional context.

Question Paper Design- R1 & R2

ENGLISH LANGUAGE – SYLLABUS CLASS – IX (2026-27) R1

SUBJECT CODE –

| Section | | Weightage |
|---------|-----------------------------|-----------|
| A | Reading Skills | 20 Marks |
| B | Writing Skills and Grammar | 30 Marks |
| C | Language through Literature | 30 Marks |
| D | Internal Assessment | 20 Marks |

Section A – Reading Skills

I. Reading Comprehension through Unseen Passage – 20 Marks (10+10)

- Descriptive/ Discursive Passage – 400-450 words – 10 Marks
- Case Based Passage (With verbal/visual inputs – statistical data/chart etc.) – 200-250 words – 10 Marks

Total Length of the two passages to be 600-700 words.

Question types to be included: Selected and constructed responses (MCQ's, Objective type, VSAQs, SAQs)

Section B – Writing Skills and Grammar – 30 Marks (10+20)

II. Grammar – 10 Marks (04+03+03)

- Sequence of Tenses in different contexts of communication
 - Modal Auxiliaries and their functions in expressing ability, obligation, permission, possibility and advice
 - Reported Speech in extended texts including
 - statements
 - questions
 - commands and requests
 - Conditional Clause – Type 1
 - Subject–Verb Concord
 - Determiners
 - Clauses – Noun Clause, Relative Clause
3. Editing/Omitting (Selected responses – MCQs) – 04 Marks
 4. Sentence Rearrangement – 03 Marks
 5. Sentence Transformation – 03 Marks

III. Writing Skills – 20 Marks (03+05+05+07)

6. Writing a Notice, Informal Invitation (Word Limit – Up to 50 words) – 3 Marks
7. Writing a Letter to Editor, Formal E-mail on a given issue for presenting views and suggestions –(Word Limit – 120-150 words) – 5 Marks
8. Writing a Factual Description, Magazine Article (Word Limit – 120-150 words) – 5 Marks
9. Writing Descriptive, Narrative Essay (Word Limit – 200-250 words) – 7 Marks

For questions 6 to 9 attempt any one as per the internal choice provided. The internal choice could comprise both same or different topics.

Section C – Language through Literature – 30 Marks (10 + 10 + 05 + 05)

IV. Extract Based Questions – 5x2 = 10 Marks

10. One extract out of two, from Drama / Prose.
11. One extract out of two, from poetry.

Types of questions to be included – Selected and constructed responses (MCQs, Objective Type Questions, VSAQs)

V. Constructed Responses (Short & Long Answer Questions)

12. Five out of Six Questions to be answered in 40-50 words. 5x2 = 10 Marks

13. One out of two Questions assessing extrapolation beyond the text and across the texts to be answered in about 120-150 words. 5 Marks
14. One out of two Questions assessing theme / plot/ character to be answered in about 120-150 words. 5 Marks

| INTERNAL ASSESSMENT 20 MARKS | |
|---|-----------------|
| Periodic Pen and Paper Tests | 05 Marks |
| Multiple Assessment (Quizzes/ Oral Discussions/Presentations etc.) | 05 marks |
| Portfolio | 05 Marks |
| Subject Enrichment projects (ALS/ Art / IKS / Tech Integrated) | 05 Marks |

ENGLISH LANGUAGE – SYLLABUS CLASS – IX (2026-27) R2**SUBJECT CODE –**

| Section | | Weightage |
|----------------|------------------------------------|------------------|
| A | Reading Skills | 20 Marks |
| B | Writing Skills and Grammar | 30 Marks |
| C | Language through Literature | 30 Marks |
| D | Internal Assessment | 20 Marks |

Section A – Reading Skills**I. Reading Comprehension through Unseen Passage – 20 Marks (12 + 8)**

- Factual/ Literary Passage – 400-450 Words – 12 Marks
- Case Based Passage (With verbal inputs) – 200-250 Words – 8 Marks

Total Length of the two passages to be 600-700 words.

(Question types to be included: Selected and constructed responses (MCQ's, Objective type, VSAQs, SAQs)

Section B – Writing Skills and Grammar – 30 Marks (10+20)**II. Grammar – 10 Marks (04+03+03)**

- Sequence of Tenses in different contexts of communication
 - Modal Auxiliaries and their functions in expressing ability, obligation, permission, possibility and advice
 - Reported Speech in extended texts including
 - statements
 - questions
 - commands and requests
 - Conditional Clause – Type 1
 - Subject–Verb Concord
 - Determiners
 - Clauses – Noun Clause, Relative Clause
3. Paragraph Completion (Selected responses: Fill ups with options) – 04 Marks
 4. Sentence Rearrangement – 03 Marks
 5. Sentence Transformation – 03 Marks

III. Writing Skills – 20 Marks (04+05+05+06)

6. Writing a Notice, Creating a Poster (Word Limit – Up to 50 words) – 4 Marks
7. Writing a Letter to the Editor, Formal E-mail on a given issue for presenting views and suggestions (Word Limit – 120-150 words) – 5 Marks
8. Writing a Speech, Magazine Article based on visual or verbal cues (Word Limit – 120-150 words) -5 Marks
9. Writing a Narrative Essay (Word Limit – 150-180 words) – 6 Marks

For questions 6 to 9 attempt any one as per the internal choice provided. The internal choice could comprise both same or different topics.

Section C – Language through Literature – 30 Marks (15 + 10 + 05)

IV. Extract-Based Questions – 5x3 = 15 Marks

10. One extract out of two, from Prose.
11. One extract out of two, from Drama.
12. One extract out of two, from Poetry.

Types of questions to be included – Selected and constructed responses (MCQs, Objective type questions, VSAQs)

V. Constructed Responses (Short & Long Answer Questions)

13. Five out of Seven Questions to be answered in 40-50 words 5x2 = 10 Marks
14. One out of two Questions to be answered in 120-150 words to assess extrapolation beyond the text and across the texts; theme / plot/ character. 5 Marks

| INTERNAL ASSESSMENT 20 MARKS | |
|---|-----------------|
| Periodic 'Pen and Paper Tests | 05 Marks |
| Multiple Assessment (Quizzes/ Oral Discussions/Presentations etc.) | 05 marks |
| Portfolio | 05 Marks |
| Subject Enrichment projects (ALS/ Art / IKS / Tech Integrated) | 05 Marks |

हिंदी पाठ्यक्रम (2026-27)

कक्षा-नवीं (आर -1)

भाषा किसी भी ज्ञान-क्षेत्र की आधारशिला है। हम प्रकृति और समाज को बहुत हद तक अपनी भाषा के ढाँचे के माध्यम से ही समझते और विश्लेषित करते हैं। इस कार्य को करने में भाषा का साहित्य हमारी विशेष सहायता करता है। माध्यमिक स्तर पर प्रवेश करने वाले विद्यार्थी सामान्य भाषा-ज्ञान से विशिष्ट अनुशासनात्मक अध्ययन की ओर बढ़ते हैं।

राष्ट्रीय शिक्षा नीति 2020 और विद्यालयी शिक्षा हेतु राष्ट्रीय पाठ्यचर्या की रूपरेखा 2023 की दृष्टि के अनुरूप यह पाठ्यक्रम हिंदी को केवल एक विषय नहीं बल्कि अनुभवों, मूल्यों, बहुसांस्कृतिकता, सृजनात्मकता और संवाद की एक समृद्ध प्रक्रिया के रूप में प्रस्तुत करता है। यह ज्ञान के संग्रह तक सीमित नहीं रहता बल्कि विद्यार्थियों को सोचने, कल्पना करने, विश्लेषण करने और अभिव्यक्ति के लिए प्रेरित करता है। पाठ्यक्रम का लक्ष्य विद्यार्थियों की चेतना को इस दिशा की ओर ले जाना है कि हिंदी भाषा के माध्यम से यथार्थ को अर्थात् जो भी घटित हो रहा है, उसे समझा जाए और उसमें अपनी आकांक्षाओं का चित्र रचा जाए। इस पाठ्यक्रम का केंद्रीय उद्देश्य पाठों का पठन-पाठन मात्र नहीं बल्कि उनके माध्यम से विद्यार्थियों में गहन पाठानुभूति, संवेदनशील अभिव्यक्ति, तार्किक विश्लेषण, संदर्भ-आधारित लेखन तथा भाषिक एवं सांस्कृतिक विविधता की समझ को विकसित करना है। हिंदी भाषा के सीखने-सिखाने के माध्यम से विद्यार्थियों में भाषा, संस्कृति का समावेशी दृष्टिकोण पैदा करना, जीवन के विविध संदर्भों को समझना, विविधता के प्रति सकारात्मकता का बोध पैदा करना- यह सब आवश्यक रूप से अपेक्षित है।

नवीं कक्षा में प्रवेश करने वाले विद्यार्थी की भाषा-शैली और विचार-बोध का एक ऐसा आधार बन चुका होता है कि अब उसे उसके भाषिक दायरे के विस्तार और वैचारिक समृद्धि के लिए आवश्यक संसाधन मुहैया कराए जाने की आवश्यकता होती है। माध्यमिक स्तर तक आते-आते विद्यार्थी किशोरावस्था में प्रवेश कर चुके होते हैं और उनमें सुनने, बोलने, पढ़ने, लिखने एवं समझने के साथ-साथ आलोचनात्मक दृष्टि विकसित होने लगती है। उनमें भाषा के सौंदर्यात्मक पक्ष, कथात्मकता, गीतात्मकता, समाचार-पत्रों की समझ, शब्द-शक्तियों के बीच अंतर की समझ, राजनैतिक चेतना एवं सामाजिक चेतना का विकास हो जाता है। वे आस-पड़ोस की भाषा और आवश्यकता के अनुसार उपयुक्त भाषा-प्रयोग, शब्दों के सुविचारित प्रयोग, भाषा की नियमबद्ध प्रकृति आदि से परिचित हो जाते हैं। इतना ही नहीं, वे विभिन्न विधाओं और अभिव्यक्ति की अनेक शैलियों से भी परिचित हो चुके होते हैं। अब विद्यार्थियों का अध्ययन आस-पड़ोस, राज्य-देश की सीमा को लाँघते हुए वैश्विक क्षितिज तक फैल जाता है। इन विद्यार्थियों की दुनिया में समाचार, खेल, फिल्म तथा अन्य कलाओं के साथ-साथ पत्र-पत्रिकाएँ और अलग-अलग तरह की पुस्तकें भी प्रवेश पा चुकी होती हैं।

एनसीईआरटी के पाठ्यक्रम और पाठ्यपुस्तकों में आर1 और आर2 के संदर्भ एनसीसीएफ-एसई 2023 के परिप्रेक्ष्य पर आधारित सांकेतिक और प्रासंगिक हैं। इन संदर्भों का उद्देश्य माध्यमिक स्तर पर आर1 और आर2 के बीच किसी भी प्रकार का संरचनात्मक या योग्यता-आधारित अंतर दर्शाना नहीं है।

पाठ्यपुस्तक की विषयवस्तु, अधिगम परिणाम और मूल्यांकन माध्यमिक स्तर पर आर 1 और आर 2 के लिए परिकल्पित सामान्य योग्यता ढाँचे के अनुरूप हैं, इसलिए संदर्भ के अनुसार इन पाठ्यपुस्तकों का लचीले ढंग से उपयोग किया जा सकता है।

इस स्तर पर हिंदी का अध्ययन-अध्यापन साहित्यिक, सांस्कृतिक और व्यावहारिक भाषा के रूप में कुछ इस तरह से हो कि माध्यमिक स्तर तक पहुँचते-पहुँचते यह विद्यार्थियों की पहचान, आत्मविश्वास और विमर्श की भाषा बन सके। आवश्यकता इस बात की है कि विद्यार्थी भाषा के लिखित प्रयोग के साथ-साथ सहज और स्वाभाविक मौखिक अभिव्यक्ति में भी सक्षम हो सकें। वे हिंदी की प्रकृति के अनुसार वर्तनी और उच्चारण के आपसी संबंधों को समझ सकें ताकि उनकी लिखित और मौखिक भाषा में समानता एवं स्पष्टता हो।

CG-1: लेखन के विभिन्न रूपों (निबंध, पत्र, लेख, चर्चा, साक्षात्कार, सार्वजनिक भाषण) और नव मीडिया (ईमेल, श्रव्य और दृश्य सामग्री) के माध्यम से प्रभावी संप्रेषण के लिए भाषा का उपयोग करना।

| दक्षताएँ | सीखने के संकेत बिंदु/गतिविधियाँ |
|---|---|
| C-3.1-विभिन्न श्रव्य और लिखित सामग्री का विश्लेषण और मूल्यांकन करना। | <ul style="list-style-type: none"> विभिन्न प्रकार की श्रव्य और लिखित सामग्री में विवरणों का अवलोकन और विश्लेषण करके उन्हें व्यवस्थित रूप से लिखते हैं। किसी एक विषय पर विभिन्न स्रोतों से प्राप्त सामग्री का विश्लेषण करके उसकी विश्वसनीयता की जाँच करते हैं। |
| C-3.2-रचना में परिवेश का सावधानीपूर्वक मूल्यांकन करके उचित तर्कों के साथ चर्चा-परिचर्चा करना। | <ul style="list-style-type: none"> पाठ्यवस्तु को पढ़ते और सुनते समय स्वयं के पूर्वग्रहों को पहचानते हैं और साक्ष्यों का मूल्यांकन करके पाठ्यवस्तु/श्रव्य-सामग्री की विश्वसनीयता का निर्धारण करते हैं। |

पाठ्यचर्या CG-4: भारतीय भाषाई विविधता से जुड़ी साहित्यिक और सांस्कृतिक विरासत की सराहना करना।

| दक्षताएँ | सीखने के संकेत बिंदु/गतिविधियाँ |
|---|---|
| C-4.1-पाठ को पढ़ते हुए विभिन्न शैलियों की सामग्री के अवलोकन के माध्यम से भारतीय समाज और साहित्यिक विविधता की बहुभाषी प्रकृति की पहचान करना। | <ul style="list-style-type: none"> भारतीय समाज की बहुभाषी प्रकृति को पहचानने के लिए विभिन्न क्षेत्रीय भाषाओं के चलचित्र और वृत्तचित्र देखते हैं और उनके बारे में अपने विचार साझा करते हैं। |
| C-4.2-भारतीय भाषाओं की विभिन्न साहित्यिक रचनाओं में निहित संस्कृति एवं विरासत की विविधता और उनके आपसी संबंधों की सराहना करना। | <ul style="list-style-type: none"> पढ़ी गई साहित्यिक रचनाओं को विषयों, पात्रों और परिस्थितियों के आधार पर अपने व्यक्तिगत अनुभवों/जीवन से जोड़ते हैं। विभिन्न भारतीय भाषाओं के साहित्य की विशिष्टता और साहित्य जगत में उनके योगदान की सराहना करते हैं। |
| C-4.3-हमारी संस्कृति और पहचान के निर्माण में भाषा की भूमिका को समझते हुए अभिव्यक्त करना। | <ul style="list-style-type: none"> भाषा में निहित सांस्कृतिक परंपराओं से प्रभावित कहावतों/पहेलियों/मुहावरों के उदाहरण साझा करते हैं। लिखने और बोलने में सांस्कृतिक परंपराओं से प्रभावित अपनी भाषा की शब्दावली का संदर्भों के अनुसार उपयुक्त उपयोग करते हैं। |

| हिंदी पाठ्यक्रम - आर -1 (2026 - 27) | | | |
|--------------------------------------|--------------------|--|--------|
| कक्षा - नवीं | | | |
| खंड | | | भारांक |
| क | अपठित बोध | | 14 |
| ख | व्यावहारिक व्याकरण | | 16 |

| | | | |
|--|---|-------|---------|
| ग | पाठ्यपुस्तक | | 30 |
| घ | रचनात्मक लेखन | | 20 |
| • भारांक - 80 (वार्षिक परीक्षा) +20 (आंतरिक परीक्षा) | | | |
| खंड -क (अपठित बोध) | | उपभार | कुल भार |
| विषयवस्तु | | | |
| 1 | अपठित गद्यांश व काव्यांश पर बोध, चिंतन, विश्लेषण, सराहना आदि पर बहुविकल्पीय, अतिलघूत्तरात्मक एवं लघूत्तरात्मक प्रश्न | | 14 |
| अ | एक अपठित गद्यांश लगभग 200 शब्दों का इसके आधार पर एक अंकीय तीन बहुविकल्पी प्रश्न (1x3=3) पूछे जाएँगे, अतिलघूत्तरात्मक एवं लघूत्तरात्मक प्रश्न (2x2=4) पूछे जाएँगे | 7 | |
| ब | एक अपठित काव्यांश लगभग 80-100 शब्दों का इसके आधार पर एक अंकीय तीन बहुविकल्पी प्रश्न (1x3=3) पूछे जाएँगे, अतिलघूत्तरात्मक एवं लघूत्तरात्मक प्रश्न (2x2=4) पूछे जाएँगे | 7 | |
| खंड -ख (व्यावहारिक व्याकरण) | | | |
| 2 | व्याकरण के लिए निर्धारित विषयों पर विषयवस्तु का बोध, भाषिक बिंदु /संरचना आदि पर अतिलघूत्तरात्मक एवं लघूत्तरात्मक प्रश्न (1X16 = 16) कुल 20 प्रश्न पूछे जाएँगे, जिनमें से केवल 16 प्रश्नों के उत्तर देने होंगे | | 16 |
| | (i) शब्द -निर्माण उपसर्ग - 2 अंक ,प्रत्यय - 2 अंक (5 प्रश्नों में से 4 प्रश्न करने होंगे) | 4 | |
| | (ii) संज्ञा, सर्वनाम,विशेषण,क्रिया (5 प्रश्नों में से 4 प्रश्न करने होंगे) | 4 | |
| | (iii) अर्थ की दृष्टि से वाक्य-भेद - 4 अंक (5 प्रश्नों में से 4 प्रश्न करने होंगे) | 4 | |

| | | | | |
|---|-------|---|---|----|
| | (iv) | अलंकार - 4 अंक शब्दालंकार : अनुप्रास, यमक, श्लेष (5 प्रश्नों में से 4 प्रश्न करने होंगे) | 4 | |
| 3 | | खंड -ग (पाठ्यपुस्तक) | | 30 |
| 4 | | खंड -घ (रचनात्मक लेखन) | | 20 |
| | | लेखन | | |
| | (i) | विभिन्न विषयों और संदर्भों पर विद्यार्थियों के तर्कसंगत विचार प्रकट करने की क्षमता को परखने के लिए संकेत-बिंदुओं पर आधारित समसामायिक एवं व्यावहारिक जीवन से जुड़े हुए तीन विषयों में से किसी एक विषय पर लगभग 120 शब्दों में अनुच्छेद लेखन । | 5 | |
| | (ii) | अभिव्यक्ति की क्षमता पर केंद्रित अनौपचारिक दो विषयों में से किसी एक विषय पर लगभग 100 शब्दों में पत्र लेखन । (विकल्प सहित) | 5 | |
| | (iii) | दिए गए विषय / परिस्थिति के आधार पर लगभग 80 शब्दों में संवाद लेखन । (विकल्प सहित) | 5 | |
| | (iv) | दिए गए विषय / शीर्षक के आधार पर लगभग 80 शब्दों में सूचना लेखन । (विकल्प सहित) | 5 | |

राष्ट्रीय शैक्षिक अनुसंधान केंद्र द्वारा राष्ट्रीय पाठ्यचर्या की रूपरेखा 2023 के आधार पर जारी की गई पाठ्यपुस्तक के आधार पर साहित्य से संबंधित अध्ययन किया जाए।

हिंदी पाठ्यक्रम (2026-27)

कक्षा-नवीं (आर -2)

राष्ट्रीय पाठ्यचर्या की रूपरेखा 2023 के अनुरूप द्वितीय भाषा के रूप में हिंदी आर 2 के रूप में पढ़ाई जाएगी। रोचक ढंग से इस भाषा का अध्ययन-अध्यापन पूर्णतः स्तरानुकूल रहेगा जिससे सभी

शिक्षार्थी लाभान्वित हो सकें तथा भारतीय भाषाओं के साथ सुरुचिपूर्ण ढंग से सामंजस्य स्थापित कर सकें ।

एनसीईआरटी द्वारा जारी पाठ्यचर्या के लक्ष्यों एवं दक्षताओं को प्रमुख रूप से ध्यान में रखते हुए शिक्षण बिंदुओं का कार्यान्वयन किया जाएगा।

भाषा किसी भी ज्ञान-क्षेत्र की आधारशिला है। हम प्रकृति और समाज को बहुत हद तक अपनी भाषा के ढाँचे के माध्यम से ही समझते और विश्लेषित करते हैं। इस कार्य को करने में भाषा का साहित्य हमारी विशेष सहायता करता है। माध्यमिक स्तर पर प्रवेश करने वाले विद्यार्थी सामान्य भाषा-ज्ञान से विशिष्ट अनुशासनात्मक अध्ययन की ओर बढ़ते हैं।

राष्ट्रीय शिक्षा नीति 2020 और विद्यालयी शिक्षा हेतु राष्ट्रीय पाठ्यचर्या की रूपरेखा 2023 की दृष्टि के अनुरूप यह पाठ्यक्रम हिंदी को केवल एक विषय नहीं बल्कि अनुभवों, मूल्यों, बहुसांस्कृतिकता, सृजनात्मकता और संवाद की एक समृद्ध प्रक्रिया के रूप में प्रस्तुत करता है। यह ज्ञान के संग्रह तक सीमित नहीं रहता बल्कि विद्यार्थियों को सोचने, कल्पना करने, विश्लेषण करने और अभिव्यक्ति के लिए प्रेरित करता है। पाठ्यक्रम का लक्ष्य विद्यार्थियों की चेतना को इस दिशा की ओर ले जाना है कि हिंदी भाषा के माध्यम से यथार्थ को अर्थात् जो भी घटित हो रहा है, उसे समझा जाए और उसमें अपनी आकांक्षाओं का चित्र रचा जाए। इस पाठ्यक्रम का केंद्रीय उद्देश्य पाठों का पठन-पाठन मात्र नहीं बल्कि उनके माध्यम से विद्यार्थियों में गहन पाठानुभूति, संवेदनशील अभिव्यक्ति, तार्किक विश्लेषण, संदर्भ-आधारित लेखन तथा भाषिक एवं सांस्कृतिक विविधता की समझ को विकसित करना है। हिंदी भाषा के सीखने-सिखाने के माध्यम से विद्यार्थियों में भाषा, संस्कृति का समावेशी दृष्टिकोण पैदा करना, जीवन के विविध संदर्भों को समझना, विविधता के प्रति सकारात्मकता का बोध पैदा करना- यह सब आवश्यक रूप से अपेक्षित है।

नवीं कक्षा में प्रवेश करने वाले विद्यार्थी की भाषा-शैली और विचार-बोध का एक ऐसा आधार बन चुका होता है कि अब उसे उसके भाषिक दायरे के विस्तार और वैचारिक समृद्धि के लिए आवश्यक संसाधन मुहैया कराए जाने की आवश्यकता होती है। माध्यमिक स्तर तक आते-आते विद्यार्थी किशोरावस्था में प्रवेश कर चुके होते हैं और उनमें सुनने, बोलने, पढ़ने, लिखने एवं समझने के साथ-साथ आलोचनात्मक दृष्टि विकसित होने लगती है। उनमें भाषा के सौंदर्यात्मक पक्ष, कथात्मकता, गीतात्मकता, समाचार-पत्रों की समझ, शब्द-शक्तियों के बीच अंतर की समझ, राजनैतिक चेतना एवं सामाजिक चेतना का विकास हो जाता है। वे आस-पड़ोस की भाषा और आवश्यकता के अनुसार उपयुक्त भाषा-प्रयोग, शब्दों के सुविचारित प्रयोग, भाषा की नियमबद्ध प्रकृति आदि से परिचित हो जाते हैं। इतना ही नहीं, वे विभिन्न विधाओं और अभिव्यक्ति की अनेक शैलियों से भी परिचित हो चुके होते हैं। अब विद्यार्थियों का अध्ययन आस-पड़ोस, राज्य-देश की सीमा को लाँघते हुए वैश्विक क्षितिज तक फैल जाता है। इन विद्यार्थियों की दुनिया में समाचार, खेल, फिल्म तथा अन्य कलाओं के साथ-साथ पत्र-पत्रिकाएँ और अलग-अलग तरह की पुस्तकें भी प्रवेश पा चुकी होती हैं।

एनसीईआरटी के पाठ्यक्रम और पाठ्यपुस्तकों में आर 1 और आर 2 के संदर्भ एनसीसीएफ-एसई 2023 के परिप्रेक्ष्य पर आधारित सांकेतिक और प्रासंगिक हैं। इन संदर्भों का उद्देश्य माध्यमिक

स्तर पर आर1 और आर2 के बीच किसी भी प्रकार का संरचनात्मक या योग्यता-आधारित अंतर दर्शाना नहीं है।

पाठ्यपुस्तक की विषयवस्तु, अधिगम परिणाम और मूल्यांकन माध्यमिक स्तर पर आर1 और आर2 के लिए परिकल्पित सामान्य योग्यता ढाँचे के अनुरूप हैं, इसलिए संदर्भ के अनुसार इन पाठ्यपुस्तकों का लचीले ढंग से उपयोग किया जा सकता है।

इस स्तर पर हिंदी का अध्ययन-अध्यापन साहित्यिक, सांस्कृतिक और व्यावहारिक भाषा के रूप में कुछ इस तरह से हो कि माध्यमिक स्तर तक पहुँचते-पहुँचते यह विद्यार्थियों की पहचान, आत्मविश्वास और विमर्श की भाषा बन सके। आवश्यकता इस बात की है कि विद्यार्थी भाषा के लिखित प्रयोग के साथ-साथ सहज और स्वाभाविक मौखिक अभिव्यक्ति में भी सक्षम हो सकें। वे हिंदी की प्रकृति के अनुसार वर्तनी और उच्चारण के आपसी संबंधों को समझ सकें ताकि उनकी लिखित और मौखिक भाषा में समानता एवं स्पष्टता हो।

CG-1: लेखन के विभिन्न रूपों (निबंध, पत्र, लेख, चर्चा, साक्षात्कार, सार्वजनिक भाषण) और नव मीडिया (ईमेल, श्रव्य और दृश्य सामग्री) के माध्यम से प्रभावी संप्रेषण के लिए भाषा का उपयोग करना।

| दक्षताएँ | सीखने के संकेत बिंदु/गतिविधियाँ |
|---|---|
| C-3.1-विभिन्न श्रव्य और लिखित सामग्री का विश्लेषण और मूल्यांकन करना। | <ul style="list-style-type: none"> विभिन्न प्रकार की श्रव्य और लिखित सामग्री में विवरणों का अवलोकन और विश्लेषण करके उन्हें व्यवस्थित रूप से लिखते हैं। किसी एक विषय पर विभिन्न स्रोतों से प्राप्त सामग्री का विश्लेषण करके उसकी विश्वसनीयता की जाँच करते हैं। |
| C-3.2-रचना में परिवेश का सावधानीपूर्वक मूल्यांकन करके उचित तर्कों के साथ चर्चा-परिचर्चा करना। | <ul style="list-style-type: none"> पाठ्यवस्तु को पढ़ते और सुनते समय स्वयं के पूर्वग्रहों को पहचानते हैं और साक्ष्यों का मूल्यांकन करके पाठ्यवस्तु/श्रव्य-सामग्री की विश्वसनीयता का निर्धारण करते हैं। |

पाठ्यचर्या CG-4: भारतीय भाषाई विविधता से जुड़ी साहित्यिक और सांस्कृतिक विरासत की सराहना करना।

| दक्षताएँ | सीखने के संकेत बिंदु/गतिविधियाँ |
|---|---|
| C-4.1-पाठ को पढ़ते हुए विभिन्न शैलियों की सामग्री के अवलोकन के माध्यम से भारतीय समाज और साहित्यिक विविधता की बहुभाषी प्रकृति की पहचान करना। | <ul style="list-style-type: none"> भारतीय समाज की बहुभाषी प्रकृति को पहचानने के लिए विभिन्न क्षेत्रीय भाषाओं के चलचित्र और वृत्तचित्र देखते हैं और उनके बारे में अपने विचार साझा करते हैं। |
| C-4.2-भारतीय भाषाओं की विभिन्न साहित्यिक रचनाओं में निहित संस्कृति एवं विरासत की विविधता और उनके आपसी संबंधों की सराहना करना। | <ul style="list-style-type: none"> पढ़ी गई साहित्यिक रचनाओं को विषयों, पात्रों और परिस्थितियों के आधार पर अपने व्यक्तिगत अनुभवों/जीवन से जोड़ते हैं। विभिन्न भारतीय भाषाओं के साहित्य की विशिष्टता और साहित्य जगत में उनके योगदान की सराहना करते हैं। |
| C-4.3-हमारी संस्कृति और पहचान के निर्माण में भाषा की भूमिका को समझते हुए अभिव्यक्त करना। | <ul style="list-style-type: none"> भाषा में निहित सांस्कृतिक परंपराओं से प्रभावित कहावतों/पहेलियों/मुहावरों के उदाहरण साझा करते हैं। लिखने और बोलने में सांस्कृतिक परंपराओं से प्रभावित अपनी भाषा की शब्दावली का संदर्भों के अनुसार उपयुक्त उपयोग करते हैं। |

| हिंदी पाठ्यक्रम - आर - 2 (2026 - 27) | | | |
|--|--------------------|--|--------|
| कक्षा - नवीं | | | |
| खंड | | | भारांक |
| क | अपठित बोध | | 14 |
| ख | व्यावहारिक व्याकरण | | 16 |
| ग | पाठ्यपुस्तक | | 30 |
| घ | रचनात्मक लेखन | | 20 |
| <ul style="list-style-type: none"> भारांक - 80 (वार्षिक परीक्षा) +20 (आंतरिक परीक्षा) | | | |

| खंड -क (अपठित बोध) | | उपभार | कुल भार |
|-----------------------------|--|--------|---------|
| विषयवस्तु | | | |
| 1 | अपठित गद्यांश पर बोध, चिंतन, विश्लेषण, सराहना आदि पर बहुविकल्पीय, अतिलघूत्तरात्मक एवं लघूत्तरात्मक प्रश्न | | 14 |
| | दो अपठित गद्यांश लगभग 200 शब्दों के। एक अंकीय तीन बहुविकल्पी प्रश्न (1×3=3) पूछे जाएँगे अतिलघूत्तरात्मक एवं लघूत्तरात्मक प्रश्न (2×2=4) पूछे जाएँगे । | 7+7=14 | |
| खंड -ख (व्यावहारिक व्याकरण) | | | |
| 2 | व्याकरण के लिए निर्धारित विषयों पर विषयवस्तु का बोध, भाषिक बिंदु /संरचना आदि पर अतिलघूत्तरात्मक एवं लघूत्तरात्मक प्रश्न (1×16 = 16) कुल 20 प्रश्न पूछे जाएँगे, जिनमें से केवल 16 प्रश्नों के उत्तर देने होंगे । | | 16 |
| (i) | (क) शब्द भंडार समानार्थी शब्द - 2 अंक (पाठ्यपुस्तक के आधार पर) (3 प्रश्नों में से 2 प्रश्न करने होंगे) (ख) मुहावरे -2 अंक (पाठ्यपुस्तक के आधार पर) (3 प्रश्नों में से 2 प्रश्न करने होंगे) | 4 | |
| (ii) | शब्द -निर्माण उपसर्ग - 2 अंक ,प्रत्यय -2 अंक (5 प्रश्नों में से 4 प्रश्न करने होंगे) | 4 | |
| (iii) | विराम चिह्न - 2 अंक (3 प्रश्नों में से 2 प्रश्न करने होंगे) | 2 | |
| (iv) | संज्ञा -2 अंक सर्वनाम -2 अंक निपात -2 अंक (7 प्रश्नों में से 6 प्रश्न करने होंगे) | 6 | |
| 3 | खंड -ग (पाठ्यपुस्तक) | | 30 |

| | | | |
|---|------------------------|---|----|
| 4 | खंड -घ (रचनात्मक लेखन) | | 20 |
| | लेखन | | |
| | (i) | विभिन्न विषयों और संदर्भों पर विद्यार्थियों के तर्कसंगत विचार प्रकट करने की क्षमता को परखने के लिए संकेत-बिंदुओं पर आधारित समसामायिक एवं व्यावहारिक जीवन से जुड़े हुए तीन विषयों में से किसी एक विषय पर लगभग 100 शब्दों में अनुच्छेद लेखन । | 5 |
| | (ii) | अभिव्यक्ति की क्षमता पर केंद्रित अनौपचारिक दो विषयों में से किसी एक विषय पर लगभग 100 शब्दों में पत्र लेखन । (विकल्प सहित) | 5 |
| | (iii) | दिए गए विषय / परिस्थिति के आधार पर लगभग 80 शब्दों में संवाद लेखन । (विकल्प सहित) | 5 |
| | (iv) | किसी दृश्य /घटना के चित्र पर आधारित लगभग 80 शब्दों में लेखन । (बिना किसी विकल्प के) | 5 |

राष्ट्रीय शैक्षिक अनुसंधान केंद्र द्वारा राष्ट्रीय पाठ्यचर्या की रूपरेखा 2023 के आधार पर जारी की गई पाठ्यपुस्तक के आधार पर साहित्य से संबंधित अध्ययन किया जाए।